

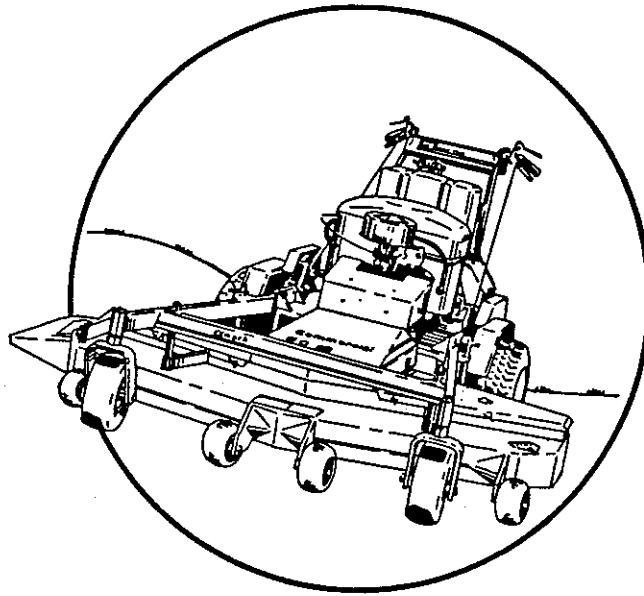

Turf Tracer



Operator's Manual

CONGRATULATIONS on the purchase of your new Exmark mower. This product has been carefully designed and manufactured to give you a maximum amount of dependability and years of trouble-free operation.

If you need to order replacement parts from your dealer, please furnish the serial number and model number from your mower, as well as the part number and description of the part you need.

For your convenience, we have provided this space for you to record the model and serial number from your mower. Please read this booklet and keep handy for operators and servicemen.

MODEL NO. _____

SERIAL NO. _____

DATE PURCHASED _____

PURCHASED FROM _____

Operator's Manual

This manual contains assembly, operating, maintenance, and adjustment instruction for your Exmark mower. Before you operate your mower, read this manual carefully in its entirety. By following the operating and maintenance instructions, you will prolong the life of your mower and maintain its maximum efficiency.

If additional information is needed, or should you require trained mechanic service, contact your authorized Exmark equipment distributor or dealer.

All Exmark equipment distributors are kept informed of the latest methods of servicing and are equipped to provide prompt and efficient service in the field or at their service stations. They carry ample stocks of service parts or can secure them promptly for you from the factory.

All Exmark parts are thoroughly tested and inspected before leaving the factory, however, some attention is required on your part. The amount of attention is slight, but important if you are to obtain the fullest measure of satisfaction and performance.

When ordering parts, always give the serial number and model of your mower as well as the quantity, part number and description of the part needed.

The serial number plate of the tractor unit is located on the top right hand side of the engine frame. The serial number plate for the deck is located on the front support pin gusset on the right hand side of the deck. We suggest you record numbers below for ready reference.

Tractor Unit Serial No. _____

Deck Serial No. _____

Date Purchased _____

Purchased From _____

TABLE OF CONTENTS

1. Safety
 - 1.1 Safety Alert Symbol
 - 1.2 Training
 - 1.3 Preparation
 - 1.4 Operation
 - 1.5 Maintenance & Storage
 - 1.6 Safety Signs
2. Specifications
 - 2.1 Model Number
 - 2.2 Engine
 - 2.3 Fuel System
 - 2.4 Electrical System
 - 2.5 Steering/Brake Control
 - 2.6 Transmission
 - 2.7 Wheel Drive System
 - 2.8 Tires
 - 2.9 Deck
 - 2.10 Dimensions
3. Assembly Instructions
 - 3.1 Uncrate Tractor and Cutter Deck
 - 3.2 Install Upper Handle
 - 3.3 Install Cutter Deck to Tractor
 - 3.4 Service Engine
 - 3.5 Service Battery
4. Operation Instructions
 - 4.1 Pre-Start
 - 4.2 Controls
 - 4.3 Operating Instructions
 - 4.4 Transporting
5. Maintenance & Adjustments
 - 5.1 Periodic Maintenance
 - 5.2 Adjustments
6. Warranty

1. SAFETY

1.1 SAFETY ALERT SYMBOL



THIS SAFETY ALERT SYMBOL IS USED BOTH IN THIS MANUAL AND ON THE MACHINE TO IDENTIFY IMPORTANT SAFETY MESSAGES WHICH MUST BE FOLLOWED TO AVOID ACCIDENTS. THIS SYMBOL MEANS: ATTENTION! BECOME ALERT! YOUR SAFETY IS INVOLVED!

This signal word used in conjunction with the safety alert symbol indicates the relative degree of a hazard:

DANGER: DENOTES THAT AN EXTREME HAZARD EXISTS WHICH WOULD RESULT IN HIGH PROBABILITY OF DEATH OR IRREPARABLE INJURY IF PROPER PRECAUTIONS ARE NOT TAKEN.

WARNING: DENOTES THAT A HAZARD EXISTS WHICH CAN RESULT IN INJURY OR DEATH IF PROPER PRECAUTIONS ARE NOT TAKEN.

CAUTION: DENOTES A REMINDER OF SAFETY PRACTICES OR DIRECTS ATTENTION TO UNSAFE PRACTICES WHICH COULD RESULT IN PERSONAL INJURY IF PROPER PRECAUTIONS ARE NOT TAKEN.

1.2 Training

- 1.2.1 Regard the Exmark mower as a piece of power equipment and teach this regard to all who operate this unit.
- 1.2.2 Read the instructions carefully. Be familiar with the controls and the proper use of the equipment.
- 1.2.3 Never allow children, young teenagers, or people unfamiliar with these instructions to use the mower.
- 1.2.4 Avoid mowing while people, especially children or pets, are nearby. Keep in mind that the operator or user is responsible for accidents or hazards occurring to other people or their property.

1.3 Preparation

- 1.3.1 The use of personal protective equipment, such as (but not limited to) protection for the eyes, ears, feet and head is recommended.

- 1.3.2 While mowing, always wear substantial footwear and long trousers. Do not operate the equipment when barefoot or wearing open sandals.
- 1.3.3 Thoroughly inspect the area where the equipment is to be used and remove all stones, sticks, wires, bones and other foreign objects.
- 1.3.4  **DANGER: FUEL IS HIGHLY FLAMMABLE.**
- a) **STORE FUEL IN CONTAINERS SPECIFICALLY DESIGNED FOR THIS PURPOSE.**
 - b) **REFUEL OUTDOORS ONLY. DO NOT SMOKE WHILE REFUELING.**
 - c) **ADD FUEL BEFORE STARTING THE ENGINE. NEVER REMOVE THE CAP OF THE FUEL TANK OR ADD FUEL WHILE ENGINE IS RUNNING OR WHEN ENGINE IS HOT.**
 - d) **IF FUEL IS SPILLED, DO NOT ATTEMPT TO START THE ENGINE. MOVE AWAY FROM THE AREA OF THE SPILL AND AVOID CREATING ANY SOURCE OF IGNITION UNTIL FUEL VAPORS HAVE DISSIPATED.**

1.4 Operation

- 1.4.1 Give complete, undivided attention to the job at hand.
- 1.4.2 Do not operate the engine in a confined space where dangerous carbon monoxide fumes can collect.
- 1.4.3 Mow only in daylight or good artificial light.
- 1.4.4 Avoid operating the equipment in wet grass, when feasible.
- 1.4.5 Mow across the face of steep slopes, never up and down. Exercise extreme caution when changing direction on slopes. Do not mow excessively steep slopes.
- 1.4.6 Use extreme caution when backing up.
- 1.4.7 Stop the blades when crossing surfaces other than grass and when transporting the mower to and from the area to be mowed.

- 1.4.8 Never operate the mower with defective guards, shields, or without safety devices in place.
- 1.4.9 Do not change the engine governor settings or overspeed the engine. Operating an engine at excessive speed may increase the hazard of personal injury.
- 1.4.10 Disengage blade drive before starting.
- 1.4.11 Start the engine carefully with feet well away from the blades.
- 1.4.12 Keep hands, feet and clothing away from rotating parts while the mower is being operated.
- 1.4.13 Stop the engine and remove the ignition key on electric start engines or disconnect the spark plug wire cable on manual start engines.
 - a) Before checking, cleaning or working on the mower.
 - b) After striking a foreign object (inspect the mower for damage and make repairs before restarting and operating the mower).
 - c) Before clearing blockages.
 - d) Whenever you leave the mower.
 - e) Before refueling.
 - f) Before making height adjustments.
- 1.4.14 Return the throttle control to the idle position for 30 seconds for engine cool down before stopping the engine.
- 1.4.15 The fuel system is provided with a shut-off valve. The fuel shut-off valve is used to shut off the fuel when machine will not be used for a few days, when parking inside a building, or during transport to and from the job.
- 1.4.16 This mower was designed for one operator only. Keep all others off mower during operation.
- 1.4.17 Do not mow without grass deflector or entire grass collection system in place and in proper working condition.
- 1.4.18 Do not operate machine unless all guards, shields, and covers are in place and in proper working condition.

- 1.4.19 If jump starting for electric start engines is required, connect positive (+) power cable from booster battery to positive power terminal post on starter solenoid switch. This post has the positive battery cable attached to it. Connect the ground (-) cable from booster battery to any engine deck ground, preferable the engine block. Disconnect cables in reverse order after starting.



CAUTION

- 1.4.20 **ALTHOUGH HAZARD CONTROL AND ACCIDENT PREVENTION PARTIALLY ARE DEPENDENT UPON THE DESIGN AND CONFIGURATION OF THE EQUIPMENT, THESE FACTORS ARE ALSO DEPENDENT UPON THE AWARENESS, CONCERN, PRUDENCE, AND PROPER TRAINING OF THE PERSONNEL INVOLVED IN THE OPERATION, TRANSPORT, MAINTENANCE AND STORAGE OF THE EQUIPMENT. IT IS ESSENTIAL THAT ALL OPERATOR SAFETY MECHANISMS BE CONNECTED AND IN OPERATING CONDITION PRIOR TO USE FOR MOWING.**

1.5 Maintenance and Storage

- 1.5.1 Precisely follow the engine manufacturer's recommendations for maintenance.
- 1.5.2 If carburetor adjustment is necessary, stand to one side and keep feet and hands clear while making adjustments.
- 1.5.3 Keep engine free from accumulation of grass, leaves or excessive grease or oil. An accumulation of these combustible materials may result in a fire.
- 1.5.4 Store fuel in a container specifically designed for this purpose in a cool, dry place.
- 1.5.5 Keep the mower and fuel container in locked storage to prevent children from playing or tampering with them.
- 1.5.6 Gasoline powered equipment or fuel containers should not be stored in a basement or any closed area, where heat appliances or open pilot lights are present, unless completely drained of fuel.
- 1.5.7 Maximum mowing results and safety can only be achieved if the mower is properly maintained and operated correctly.

- 1.5.8 Check all bolts frequently to maintain proper tightness.
 - 1.5.9 Keep all guards, shields and other safety devices in place and in safe working condition.
 - 1.5.10 Check for worn or deteriorating components that could create a hazard.
 - 1.5.11 All replacement parts must be the same as or equivalent to the parts supplied as original equipment.
- 1.6 Safety Signs**
- 1.6.1 Keep all safety signs legible. Remove all grease, dirt and debris from safety signs.
 - 1.6.2 Safety signs must be replaced if they are missing or illegible.
 - 1.6.3 When new components are installed, be sure that current safety signs are affixed to the replaced components.
 - 1.6.4 New safety signs may be obtained from your authorized Exmark equipment dealer or distributor or from Exmark Mfg. Co. Inc.
 - 1.6.5 Safety signs may be affixed by peeling off the backing to expose the adhesive surface. Apply only to a clean, dry surface. Smooth to remove any air bubbles.
 - 1.6.6 Familiarize yourself with the following safety signs. They are critical to the safe operation of your Exmark commercial mower.



LOCATION: On Battery Cover



LOCATION: LH and RH Front Top Surface of Mower Deck



LOCATION: Upper Handle

WARNING		ANTI-SCALP ROLLER ADJUSTMENT																									
DISENGAGE BLADE CLUTCH, SHUT OFF ENGINE AND REMOVE KEY BEFORE MAKING ADJUSTMENTS, SERVICING OR CLEANING DECK.		FOR MAXIMUM DECK FLOTATION, PLACE ROLLERS IN POSITIONS SHOWN.																									
CUTTING HEIGHT ADJUSTMENT <table border="0"> <tr> <td>1.5 (38)</td> <td>CUTTING HEIGHT</td> </tr> <tr> <td>2.0 (51)</td> <td></td> </tr> <tr> <td>2.5 (64)</td> <td></td> </tr> <tr> <td>3.0 (76)</td> <td></td> </tr> <tr> <td>3.5 (90)</td> <td></td> </tr> <tr> <td>4.0 (102)</td> <td>INCHES(mm)</td> </tr> <tr> <td>4.5 (114)</td> <td></td> </tr> </table>		1.5 (38)	CUTTING HEIGHT	2.0 (51)		2.5 (64)		3.0 (76)		3.5 (90)		4.0 (102)	INCHES(mm)	4.5 (114)		<table border="0"> <tr> <td>CUTTING HEIGHT</td> <td>INCHES(mm)</td> </tr> <tr> <td>1.5</td> <td>(38)</td> </tr> <tr> <td>2.0</td> <td>(51)</td> </tr> <tr> <td>2.5</td> <td>(64)</td> </tr> <tr> <td>3.0</td> <td>(76)</td> </tr> </table>		CUTTING HEIGHT	INCHES(mm)	1.5	(38)	2.0	(51)	2.5	(64)	3.0	(76)
1.5 (38)	CUTTING HEIGHT																										
2.0 (51)																											
2.5 (64)																											
3.0 (76)																											
3.5 (90)																											
4.0 (102)	INCHES(mm)																										
4.5 (114)																											
CUTTING HEIGHT	INCHES(mm)																										
1.5	(38)																										
2.0	(51)																										
2.5	(64)																										
3.0	(76)																										
DECK SUPPORT PIN		ROLLERS SHOULD MAINTAIN 1/4" (6.4) CLEARANCE TO GROUND. DO NOT ADJUST ROLLERS TO SUPPORT MOWER DECK. 543880																									

LOCATION: Centered on Front of Mower Deck Top Surface

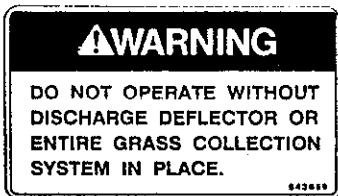

LOCATION: On Top Rear RH Surface of Mower Deck

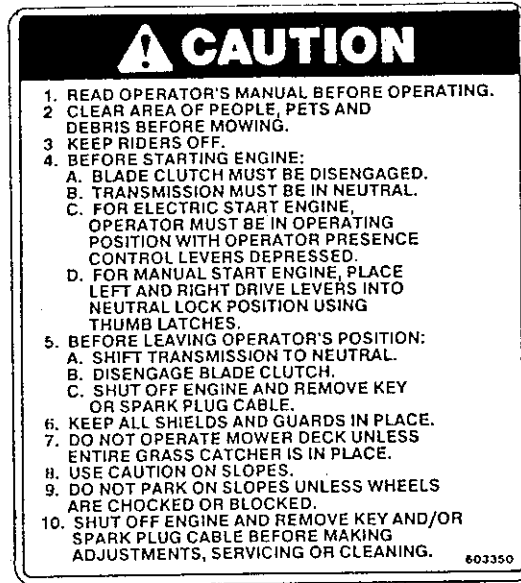

LOCATION: Front Right Corner
of Engine Deck
(Kaw. 17 & Kohler 18 hp)

Front Left Corner
of Engine Deck
(Kawasaki 14 hp)



LOCATION: On Top Front LH
Surface of Engine
Deck Next to
Muffler Shield

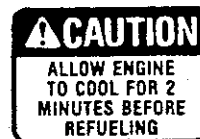

LOCATION: On Strap of Fuel Tank

2. SPECIFICATIONS

2.1 **Model Number:** TT-14K, TT-17K and TT-18KO

2.2 **Engine:** See your engine owner's manual

2.3 **Fuel System**

2.3.1 **Capacity:** 5.0 gal. (18.9 L.)

2.3.2 **Type of Fuel:** Regular unleaded gasoline, 87 octane or higher

2.3.3 **Fuel Filter:** Replaceable in-line

2.3.4 **Fuel Shut-Off Valve:** 1/4 turn

2.4 **Electrical System:** For Kawasaki 17 hp and Kohler 18 hp engines

2.4.1 **Charging System:** Flywheel Alternator

2.4.2 **Charging Capacity:** 15 amp (pull start Kawasaki 14 hp engines - 13 amp)

2.4.3 **Battery Type:** BCI Group U1 235 amps at 0° F

2.4.4 **Battery Voltage:** 12 Volt

2.4.5 **Polarity:** Negative Ground

2.4.6 **Fuses:** blade type, 20 amp to charging circuit; 20 amp to electric clutch.

2.4.7 **Safety Interlock System:** Operator must have OPC levers held in contact with handle grips, transmission in neutral and blade clutch disengaged to start engine. Release of OPC levers will cause the engine to stop if transmission is not in neutral and/or blade clutch is engaged (all models).

2.5 **Steering/Brake Control:** Fingertip drive control levers provide independent control of traction, braking and neutral to each drive wheel for moving, stopping and power turning.

2.6 **Transmission**

2.6.1 **Pearless 700, with low torque drive, 5 speeds forward, 1 reverse.**

2.6.2 **Speed Range:**

1st	1.4 mph	(2.3 km/h)
2nd	2.2 mph	(3.5 km/h)
3rd	3.3 mph	(5.3 km/h)
4th	4.2 mph	(6.8 km/h)
5th	5.0 mph	(8.0 km/h)
Reverse	1.6 mph	(2.7 km/h)

2.7 **Wheel Drive System:** Single "B" section V-belt with Positrac Pulley and dual idlers.

2.8 **Tires**

	<u>Drive</u>	<u>Front Cstr.</u>
Size:	16 x 6.50-8	9 x 3.50-4
Quantity:	2	2
Tread:	Turfsaver	Smooth
Ply Rating:	2	4
Pressure:	14 psi (97 kPa)	22 psi (152 kPa)

2.9 **Deck**

- 2.9.1 Cutting Width: 60 in. (152.4 cm.); 52 in. (132.08 cm.)
- 2.9.2 Discharge: Right Side
- 2.9.3 Blade Size: 60 in. - (3) 20.50 in. (52.1 cm.)
52 in. - (3) 18.00 in. (45.72 cm.)
- 2.9.4 Type of Drive: Electric clutch mounted on engine shaft. Blades driven by two belts with self tensioning idlers.
- 2.9.5 Deck Mounting: Full floating deck is attached to out-front support frame. Removable for servicing.
- 2.9.6 Cutting Height: Adjusts from 1.5 in. (3.8 cm.) to 4.5 in. (11.5 cm.) in .5 inch (1.3 cm.) increments.

2.10 **Dimensions**

- 2.10.1 Overall Width:
 - w/60"
deflector down - 70.5 in. (179.1 cm.)
deflector up - 60.9 in. (154.6 cm.)
 - w/52"
deflector down - 62.7 in. (159.26 cm.)
deflector up - 53.0 in. (134.62 cm.)
- 2.10.2 Overall Length w/60": 80 in. (203.2 cm.)
Overall Length w/52": 80.88 in. (205.44 cm.)
- 2.10.3 Overall Height: 43.5 in. (110.5 cm.)
- 2.10.4 Tread Width: 36.5 in. (92.7 cm.) drive wheels
- 2.10.5 Curb Weight:
 - 680 lb. (308 kg.) total 60" deck w/18 hp Koh. trac.
 - 664 lb. (301 kg.) total 52" deck w/18 hp Koh. trac.
 - 651 lb. (295 kg.) total 60" deck w/17 hp Kaw. trac.
 - 635 lb. (288 kg.) total 52" deck w/17 hp Kaw. trac.
 - 605 lb. (274 kg.) total 60" deck w/14 hp Kaw. trac.
 - 589 lb. (267 kg.) total 52" deck w/14 hp Kaw. trac.

3. ASSEMBLY INSTRUCTIONS

- 3.1 Uncrate tractor, inner box and cutter deck.
- 3.2 Install upper handle assembly.
 - 3.2.1 Open inner box and lay out all parts in an orderly fashion.
 - 3.2.2 Place the lower section of the upper handle assembly on the inside of the mounting brackets on the fuel tank support. Insert four 3/8-16 x 3/4 HHCS thru the inside of the handle. Tighten securely with four flanged hex nuts.
 - 3.2.3 For 18 hp Kohler: Route choke cable on the right hand side of the engine and around the front of the carburetor. Attach cable assembly to the left hand side of the carburetor, under the air cleaner. Adjust cable position so that choke is in the fully off position when the choke cable knob is fully depressed at the control console. Secure cable clamp at the carburetor.
 - 3.2.4a For 18 hp Kohler: Route throttle cable on the right hand side of the engine. Attach the inner wire to the throttle control arm. Position the throttle control at the control console within 1/8" from the upper end of the slot. Pull on cable assembly at lower end where it attached to the engine until the throttle control arm contacts the stop screw. Secure cable with cable clamp.
 - 3.2.4b For 14 hp and 17 hp Kawasaki: Route the throttle cable to the right side of the upper handle attaching it to the upper handle with the cable clip provided. Position the throttle control at the control console within 1/8" from the upper end of the slot. Cross the throttle control over to the left side of the engine, attach the inner wire to the appropriate place on the engine. Loosen the cable clamp on the engine, place the cable behind it and pull up on the cable to move the engine linkage to the full choke position and tighten the cable clamp screw.
 - 3.2.5 Attach shifter linkage to bellcrank with a 5/16 lockwasher and a 5/16-18 nut. With transmission in neutral check position of the shifter rod in upper console shifter slot. There should be 1/16" clearance between the shifter rod and the bottom of the slot. If adjustment is necessary, remove the hardware mentioned above and rotate the balljoint to lengthen or shorten the link as required. Re-install hardware and tighten securely. Align balljoints and tighten balljoint jamnut.

- 3.2.6 Thread longest linkage into swivel on brake arm assembly. Thread short linkage into caliper linkage yoke. Do this for both sides.
- 3.2.7 Insert brake rod thru drive linkages and drive levers as shown in Figure #1; do not fasten.

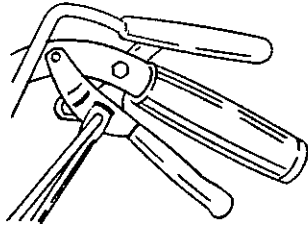

Fig. 1 Lever and Rod Adjustment

Adjust drive linkage length by threading into or out of the yoke until there is a 1/4" clearance between the linkage assembly and the bottom of the slot in the neutral lock lever as shown in Figure #2.

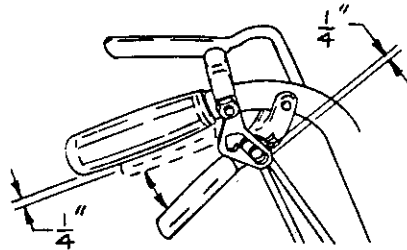

Fig. 2 Neutral Lock Lever Clearance

NOTE: This clearance should be checked when there is a slight upward force placed on the drive levers to remove any "slack" in the linkage.

- 3.2.8 Adjust brakes by threading brake rod into or out of swivel until brakes are engaged with approximately 1/4" clearance between the end of the drive lever and the handle grip. See Figure #2. Fasten brake linkage to drive lever with 5/16 washer next to the thumb latch slot and hairpin cotter. Do this for both sides.

NOTE: The thumb latches must be able to be moved into the neutral lock position, if not, re-adjust brake linkages.

- 3.2.9 Connect the upper handle and engine deck wiring harnesses. For Kawasaki 17 hp and Kohler 18 hp units, be sure the eight pin connectors and single insulated connectors are fully engaged. For Kawasaki 14 hp units, be sure the six pin connectors are fully engaged. Place the loom clamp onto the upper wiring harness and secure

3.2.9 (Con't)

with a 1/4-20 nylock nut to the outer end of the 1/4-20 x 2 HHCS which secures the fuse blocks to the fuel tank support for 17 hp and 18 hp units. See Figure #3. For Kawasaki 14 hp units, place the loom clamp onto the engine regulator mounting screw in same location as above.

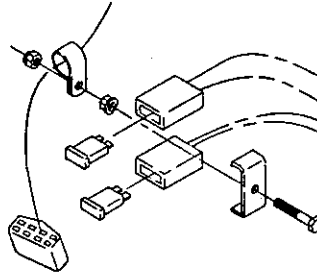

Fig. 3 Loom Clamp Attachment
(17 & 18 hp)

3.3 Cutter Deck Installation

- 3.3.1 Remove 3/8-16 x 4 HHCS, (2) 3/8 flanged hex nuts, fender spacer and a 3/8 spring disk from the forward section of each fender on the tractor unit. Retain these items for later re-installation.
- 3.3.2 Remove center cutter deck shield.
- 3.3.3 Squeeze drive levers and place the thumb latches in the neutral lock position (see Operation Instructions Section). Roll the tractor to the cutter deck assembly and allow the tractor assembly to rotate backward until the rear of the engine deck contacts the ground.
- 3.3.4 Remove cutter deck support frame from cutter deck by removing two large hairpins and washers from front deck support pins and by removing two small hairpins and washers from rear deck support pins.

⚠ CAUTION: IF TRACTOR OR TRACTOR WITH MOUNTED CUTTER DECK SUPPORT FRAME ARE NOT HELD SECURELY THE FRONT END MAY RISE UP SUDDENLY AND CAUSE UNEXPECTED INJURY WHEN THE CUTTER DECK ITSELF IS NOT INSTALLED YET. THIS MAY ALSO HAPPEN WHEN THE CUTTER DECK AND SUPPORT FRAME, WHILE CONNECTED TO THE TRACTOR, HAVE THE FRONT TWO DECK SUPPORT ROD HAIRPINS REMOVED. FRONT END OF SUPPORT FRAME MAY RISE UP SUDDENLY IF NOT HELD DOWN SECURELY.

- 3.3.5 Install cutter deck support frame to tractor engine deck and secure with six 3/8-16 x 1 HHCS hex head capscrews, six 3/8 disc spring washers and six 3/8-16 whizlock nuts. Reinstall fender fasteners as per 3.3.1 into same holes they were removed from, (See Figure #6).

NOTE: Place spring washer cone against bolt head and install whizlock nut to inside of engine deck for the two rear holes on both sides and install whizlock nut to the outside for the two front bolt holes on each side of the cutter deck support frame using fender spacers on bottom holes. Tighten until spring washers are flat. See Figures 4, 5 and 6.

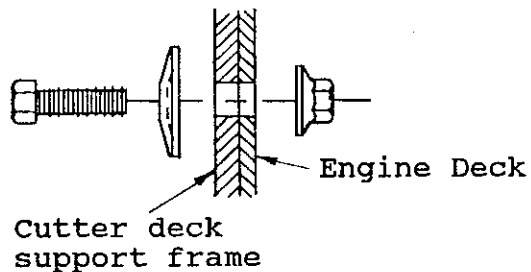

Fig. 4 Whizlock nuts to inside of engine deck for the rear two holes.

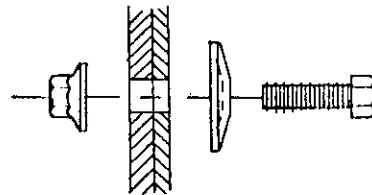

Fig. 5 Whizlock nuts to outside of cutter deck support frame for the front top holes.

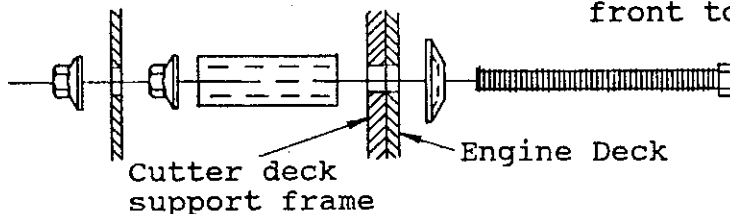

Fig. 6 Whizlock nuts to outside of cutter deck both sides of fenders; fender spacer between deck support frame and whizlock nut at front bottom holes.

- 3.3.6 Position tractor with cutter deck support frame in place, over the cutter deck.

⚠ CAUTION: IF TRACTOR OR TRACTOR WITH MOUNTED CUTTER DECK SUPPORT FRAME ARE NOT HELD SECURELY THE FRONT END MAY RISE UP SUDDENLY AND CAUSE UNEXPECTED INJURY WHEN THE CUTTER DECK ITSELF IS NOT INSTALLED YET. THIS MAY ALSO HAPPEN WHEN THE CUTTER DECK AND SUPPORT FRAME, WHILE CONNECTED TO THE TRACTOR, HAVE THE FRONT TWO DECK SUPPORT ROD HAIRPINS REMOVED. FRONT END OF SUPPORT FRAME MAY RISE UP SUDDENLY IF NOT HELD DOWN SECURELY.

3.3.6 (Con't)

Align and re-engage the cutter deck support pins into the support frame. Re-install two large hairpins and washers into the front support pins and then two smaller hairpins and washers onto the rear support pins.

- 3.3.7 Install cutter deck drive belt. First be sure belt is in the clutch drive sheave groove. Place the other end of the belt over the cutter deck drive sheave and rotate this sheave for belt to slip into sheave groove. Next, pull idler assembly back to allow belt to engage idler sheave. Replace the center cutter deck belt shield. See Figure 7. Connect clutch wiring connector.

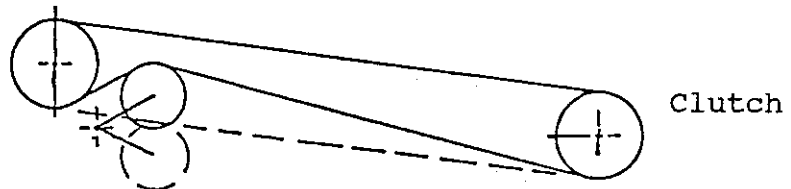



Fig. 7 Cutter Deck Drive Belt

- 3.3.8 Adjust cutting height of deck (See 5.2.1)
- 3.3.9 Squeeze drive levers and move both thumb latches into the neutral lock position. Mower should move forward and backward freely, if not re-adjust brakes as per 3.2.8.
- 3.4 Service Engine. Fill with SAE 30W, API service class SF for operating in temperatures above 30° F (0° C). See Engine Operator's Manual.
- 3.5 Service battery (17 hp Kawasaki & 18 hp Kohler). Machine is shipped with battery dry.

POISON CAUSES SEVERE BURNS 	CONTAINS SULFURIC ACID. AVOID CONTACT WITH SKIN, EYES OR CLOTHING. IN EVENT OF ACCIDENT FLUSH WITH WATER AND CALL A PHYSICIAN IMMEDIATELY. KEEP OUT OF REACH OF CHILDREN	DANGER EXPLOSIVE GASES 	CIGARETTES, FLAMES OR SPARKS COULD CAUSE BATTERY TO EXPLODE. ALWAYS SHIELD EYES AND FACE FROM BATTERY DO NOT CHARGE OR USE BOOSTER CABLES OR ADJUST POST CONNECTIONS WITHOUT PROPER INSTRUCTION AND TRAINING. KEEP VENT CAPS TIGHT AND LEVEL
--	---	--	---

- 3.5.1 Remove battery cover from machine. Disconnect battery cables - negative (black) cable first. Remove battery hold down and lift battery out.
- 3.5.2 Place battery on a level surface and remove vent caps.
- 3.5.3 Fill cells with battery grade sulfuric acid (1.625 specific gravity) to halfway between top of separators and bottom of vent well. KEEP SPARKS AND FLAMES AWAY FROM BATTERY AT ALL TIMES.

- 3.5.4 Check acid temperature and state of charge:
- A. Acid temperature must be at least 80° F (26.7° C). (Put battery thermometer in center cell.)
 - B. State of charge must be good.
 - 1. Check with electrical battery tester according to instructions on the tester
OR
 - 2. Use a battery hydrometer - specific gravity must be at least 1.250.
- 3.5.5 If acid temperature is not 80° F (26.7° C) or state of charge is not good, charge at 15 amps (20 amp maximum). ACID TEMPERATURE MUST NEVER EXCEED 125° F (51.7° C) WHILE CHARGING. Slow charging is permissible.
- 3.5.6 After charging, add battery acid to bottom of vent wells and install vent caps. Prior to installation, check battery with a hi-rate load tester following the printed instructions on the tester - "State of Charge" and "Condition" must be indicated as "good" or "OK".
- 3.5.7 Re-install battery in machine.

 **CAUTION: BE SURE IGNITION IS OFF AND KEY IS REMOVED.**

Connect cables - positive (red) cable first, then negative (black) cable. Re-install battery hold down and cover.

4. OPERATION INSTRUCTIONS

4.1 Pre-Start

- 4.1.1 Fill fuel tank. For best results use only clean, fresh regular grade unleaded gasoline with an octane rating of 87 or higher. Regular grade leaded gasoline may also be used; however, combustion chamber and cylinder head will require more frequent service. See Engine Owner's Manual.

NOTE: Fuel tank may appear loose at setup, however, once fuel is added in tank, tank will slowly expand to fit tank strap.

Do not add oil to gasoline.

Do not overfill fuel tank. Leave room for fuel to expand.

- 4.1.2 Refer to maintenance section and perform all of the necessary inspection and maintenance steps.
- 4.1.3 Familiarize yourself with controls. See Controls Section.

4.2 Controls

- 4.2.1 Drive Levers - Located on each side of the upper handle assembly directly below the handle grips. These levers individually control clutching action of the wheel drive belts and brakes. When the drive levers are all the way down the wheel drive belts are engaged and the brakes are disengaged. Squeezing the left hand or right hand drive lever causes the left hand or right hand wheel to slow down or stop, which makes the machine turn to the left or right respectively. The sharpness of the turn can be varied by how much the lever is "squeezed". If both levers are squeezed all the way back, both brakes will engage and the machine will stop. For straight ahead motion, smoothly release both drive levers to engage both drive wheels simultaneously.
- 4.2.2 Thumb Latches - Located directly above the drive levers. The purpose of these levers are to allow the operator to lock the drive levers in a "neutral" position where neither the wheel drive belts or the brakes are engaged.

To lock the drive levers in neutral, squeeze the drive levers back, place thumbs on the upper portion of the thumb latches and move them to the rear. Release drive levers.



CAUTION: BE SURE THE RODS PROTRUDING THRU THE SLOTS OF EACH THUMB LATCH ARE COMPLETELY ENGAGED IN THE REAR SLOT OF EACH LATCH, IF NOT, THE DRIVE LEVERS COULD UNEXPECTEDLY SLIP INTO THE DRIVE POSITION.

- 4.2.3 Operator Presence Control (OPC) Levers - Located on the upper handle assembly directly above the handle grips. When these levers are depressed, the OPC system senses that the operator is in the normal operator's position. When the levers are released, the OPC system senses that the operator has moved from his normal operating position and will kill the engine.

- 4.2.4 Electric Blade Clutch Engagement - Switch is located on left side of control console with safety guard. Moving the toggle switch ahead will engage the blade clutch and moving it to the rear will disengage the blade clutch. Operator must have operator presence control levers depressed when blades are engaged or engine will stop.
- 4.2.5 Choke Control (18 hp Kohler) - Located on the control console right side. Choke is used to aid in starting a cold engine. "Off" position is pushed in and "on" position pulled out. Do not run a warm engine with choke in the "on" position.
- 4.2.6a Throttle Control (18 hp Kohler) - Located on the control console right side next to the choke control. Throttle is used to control engine speed. Moving throttle control ahead will increase engine speed and moving it to the rear will decrease engine speed.
- 4.2.6b Throttle-Choke Control (14 hp & 17 hp Kawasaki) Located on the control console right side. Choke is used to aid in starting a cold engine. Choke is achieved by moving the throttle control to the full forward position. Once the engine has started, move the control from choke to the full or medium throttle position. The 14 hp Kawasaki's are equipped with throttle kill as a standard feature and moving the throttle to the full rear position will shut off the engine.
- 4.2.7 Transmission Shift Lever - Located in middle of control console, it shifts the 5-speed transmission into 5 forward gears, neutral or reverse.
- 4.2.8 Ignition Switch (17 hp Kawasaki & 18 hp Kohler) Located on the control console just below the choke control. The ignition switch has three positions - off, on and start. Insert key into switch and rotate to the right to the "on" position. Rotate to the right to the next position to engage the starter (key must be held against spring pressure in this position). Operator must have transmission in neutral, OPC levers depressed and blade clutch disengaged to start engine. When engine starts, release key.

- 4.2.9 Hour Meter - Located on the left hand side of console just above the blade clutch switch. The hour meter records the number of hours that the engine has run. If ignition switch (for 17 and 18 hp engines) is left on without engine running, hour meter will not run.
- 4.2.10 Fuel Shut-Off Valve - Located underneath the fuel tank. The fuel shut-off valve is used to shut off the fuel when machine will not be used for a few days, when parking inside a building, or during transport to and from the job. Rotate valve 1/4 turn clockwise to shut fuel off. Rotate valve 1/4 turn counterclockwise to turn fuel on.

4.3 Operating Instructions

- 4.3.1a Starting Engine (17 hp Kaw. & 18 hp Kohler) - Operator must have operator presence control levers depressed, the blade clutch disengaged and transmission in neutral.

Open fuel shut-off valve.

On a cold Kohler 18 hp engine, place the throttle midway between "slow" and "fast" positions and place the choke in the "on" position. On a warm engine, place the throttle midway between "slow" and "fast" positions and leave the choke in the "off" position.

On a cold Kawasaki 17 hp engine, place the throttle in the full "choke" position. On a warm engine, place the throttle midway between "slow" and "fast" positions.

NOTE: Kawasaki engines generally need to be "choked" even when warm.

Turn ignition switch to "start" position.
Release the switch as soon as the engine starts.

On a cold engine, gradually return choke to "off" position after engine starts and warms up.

IMPORTANT: Do not crank the engine continuously for more than ten (10) seconds at a time. If the engine does not start, allow a 60 second starter cool-down period between starting attempts. Failure to follow these guidelines can burn out the starter motor.

NOTE: It is helpful to have the left and right neutral lock thumb latches applied when starting the engine. (See 4.2.2)

- 4.3.1b Starting Engine (14 hp Kawasaki) - Operator must have blade clutch disengaged and transmission in neutral.

Open fuel shut-off valve.

On a cold engine, place the throttle in the full "choke" position. On a warm engine, place the throttle midway between "slow" and "fast" positions.

NOTE: Kawasaki engines generally need to be "choked" even when warm.

Pull the recoil rope to start the engine. On a cold engine, gradually return choke to full throttle position after engine starts and warms up.

NOTE: It is helpful to have the left and right neutral lock thumb latches applied when starting the engine. (See 4.2.2)

- 4.3.2 Stopping Engine - Disengage blade clutch, shift transmission to neutral and lock drive levers in neutral. Move throttle to "slow" position. Allow engine to idle for 30 seconds to allow cool down. Rotate ignition switch to "off" position for 17 hp and 18 hp engines. Remove key to prevent children or other unauthorized persons from starting engine. For 14 hp engines, pull throttle lever all the way down to stop engine. Close fuel shut-off valve when machine will not be used for a few days or when parking inside a building or when transporting.

- 4.3.3 Drive Wheel Engagement/Turning - With drive levers located in neutral, shift transmission into desired gear. Squeeze both drive levers and move both thumb latches from the neutral lock position. For straight ahead motion, smoothly release both drive levers to engage drive wheels. Squeeze right hand drive lever to turn right and left hand drive lever to turn left.

- 4.3.4 To Stop - Squeeze drive levers all the way back to engage brakes. Move Thumb Lock Latches into the neutral lock position and shift transmission into neutral.

- 4.3.5 Engaging Electric Blade Clutch - The electric blade clutch toggle switch engages the cutting blades. Be sure that all persons are clear of mower deck and discharge area before engaging the blade clutch.

4.3.5 (Con't)

Set throttle to "midway" position on 17 hp and 18 hp engines; "fast" position on 14 hp. Lift the toggle switch guard. Flip toggle switch ahead to the "on" position. Accelerate to full throttle to begin mowing with 17 hp and 18 hp engines.

- 4.3.6 Stopping Electric Blade Clutch - Flip the toggle switch guard rearward with a quick positive motion. This moves the toggle switch to the off position to stop the cutting blades.

4.4 **Transporting**

Use a heavy duty trailer to transport the machine. Engage neutral lock thumb latches and block wheels. Securely fasten the machine to the trailer with straps, chains, cables or ropes. Be sure that the trailer has all necessary lighting and marking as required by law and use a safety chain.

5. MAINTENANCE & ADJUSTMENTS

5.1 **Periodic Maintenance**

- 5.1.1 Check engine oil level.

Service Interval: See Engine Owner's Manual

- a. Make sure engine is stopped and on a level surface.
- b. Check with engine cold.
- c. Clean area around dipstick. Remove dipstick and wipe oil off. Reinsert the dipstick and push it all the way into the tube. Again, remove dipstick and check oil level.
- d. See engine owner's manual for further procedures.

- 5.1.2 Clean engine air cooling system.

Service Interval: See Engine Owner's Manual

- a. Stop engine and remove ignition key and/or spark plug cable.
- b. Clean all debris from engine air intake screen and from around engine shrouding.

- 5.1.3 Clean grass build-up under deck and check mower blades.

Service Interval: Daily

- a. Disengage electric blade clutch.
- b. Stop engine and remove ignition key and/or spark plug cable.

5.1.3 (Con't.)

- c. Raise deck, block up and use proper safety precautions.
- d. Clean out any grass build-up from underside of deck and in deck discharge chute.
- e. Inspect blades and sharpen or replace as required.
- f. Torque blade bolts to 40 FT-LBS. Be sure the spring disk washer cone is installed toward the bolt head. (See Figure 8.)
- g. Lower deck to ground.

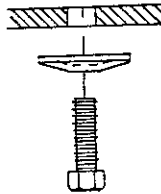



Fig. 8 Blade Bolt Installation

5.1.4a Check safety interlock system - electric start engines only.
Service Interval: Daily

- a. Check starting circuit. Starter should crank with operator presence control levers depressed, transmission in neutral, and electric blade clutch disengaged. Try to start with operator presence control levers disengaged, transmission in neutral and electric blade clutch disengaged - starter must not crank. Try to start with operator presence control levers depressed, transmission in any gear but neutral and electric blade clutch disengaged - starter must not crank. Try to start with operator presence control lever depressed, transmission in neutral and electric blade clutch engaged - starter must not crank.
- b. Check operator presence control (OPC) circuits. Run engine at one-third throttle, then with drive levers and thumblock latches in neutral lock position, shift transmission into forward gear and release OPC levers - engine must stop. Again, run engine at one-third throttle, shift transmission to neutral, engage electric blade clutch and release OPC levers - engine must stop.
- c. If machine does not pass any of these tests, do not operate. Contact your authorized EXMARK SERVICING DEALER.

 **CAUTION: IT IS ESSENTIAL THAT OPERATOR-SAFETY MECHANISMS BE CONNECTED AND IN PROPER OPERATING CONDITION PRIOR TO USE FOR MOWING.**

5.1.4b Check safety interlock system - manual start engines only.

Service Interval: Daily

- a. For your safety, your Exmark mower is equipped with Operator Presence Controls (OPC). When either the mower blades or the traction drive is engaged and both hands are removed from the handles, the mower engine should stop.
- b. To determine if the OPC is in operating condition, clear the area and, with the transmission in neutral, engage the cutter blades, momentarily release the OPC levers and the engine should begin to stop. With the blades disengaged, shift the transmission into gear and release the OPC levers and the engine should stop.
- c. If the mower engine does not stop under any of the above conditions, contact your authorized Exmark service dealer.



CAUTION: IT IS ESSENTIAL THAT OPERATOR SAFETY MECHANISMS BE CONNECTED AND IN PROPER OPERATING CONDITION PRIOR TO USE FOR MOWING.

5.1.5 Check Brake and Wheel Drive Linkage Adjustment.
(See 3.2.7 and 3.2.8)

5.1.6 Check for loose hardware.
Service Interval: Daily

- a. Stop engine and remove ignition key and/or spark plug cable.
- b. Visually inspect machine for any loose hardware or any other possible problem. Tighten hardware or correct the problem before operating.

5.1.7 Service pre-cleaner element and air cleaner.
Service Interval: See Engine Owner's Manual

- a. Stop engine and remove ignition key and/or spark plug cable.
- b. See engine owner's manual for cleaning instructions.

5.1.8 Change engine oil.
Service Interval: See Engine Owner's Manual

- a. Disengage electric blade clutch.
- b. Stop engine and remove ignition key and/or spark plug cable.
- c. Drain oil while engine is warm from operation.

5.1.8 (Con't.)

- d. Remove the oil drain plug from the right hand side of the engine. Allow oil to drain, then replace drain plug.
- e. Replace the oil filter as per engine owner's manual. Clean around oil filter and unscrew filter to remove. Before reinstalling new filter, apply a thin coating of oil on the surface of the rubber seal.

Turn filter clockwise until rubber seal contacts the filter adapter then tighten filter an additional $2/3$ to $3/4$ turn.

- f. Clean around oil fill cap and remove cap. Fill to specified capacity and replace cap. Use oil as specified in Engine Owners Manual. Do not overfill.
- g. Start the engine and check for leaks. Stop engine and recheck oil levels.

5.1.9 Check tire pressures.
Service Interval: 25 hrs.

- a. Stop engine and remove ignition key and/or spark plug cable.
- b. Inflate tires to pressures specified in Specifications Section.

5.1.10 Check battery electrolyte level for electric start engines.
Service Interval: 25 hrs.

- a. Stop engine and remove ignition key and/or spark plug cable.
- b. Remove battery cover.
- c. Remove vent caps from battery. Fill with drinking water to bottom of vent wells and replace vent caps.
- d. See Assembly Section for servicing a new battery.

5.1.11 Check Low Torque Drive Chain
Service Interval: 25 hrs. (Check After First 10 Hrs. of Operation)

- a. Stop engine and remove ignition key and/or spark plug cable.
- b. Place drive levers and thumblock latches in the neutral lock position.
- c. Check chain for proper tension. Move the chain up and down in the middle of the bottom span between the sprockets. The chain should move a minimum of $3/8$ " and a maximum of $1\ 3/8$ ". See 5.2.8 if adjustment is needed.

5.1.12 Check Low Torque Drive Sprocket Alignment
Service Interval: 50 hrs. (Check after first
 10 hrs. of operation)

- a. Stop engine and remove ignition key and/or spark plug cable.
- b. Remove the transmission chain guard.
- c. Place a short 6" straight edge across the left surface of the jackshaft sprocket plate to the transmission sprocket edge. If there is more than a 1/16" gap between the straight edge and the matching left side of the transmission sprocket, they are not properly aligned.
- d. If sprockets are out of alignment, see Section 5.2.9b for adjustment procedures.

5.1.13 Inspect Beltwear.
Service Interval: 25 hrs.

- a. Stop engine and remove ignition key and/or spark plug cable.
- b. Remove the three cutter deck belt shields to check mower primary and secondary belt condition.
- c. Look under engine deck to check the transmission drive belt condition.
- d. Remove wheel drive belt fender/guards and inspect drive belt conditions.
- e. Check all idler arms to be sure they pivot freely.

5.1.14 Lubrication

- a. Stop engine and remove ignition key and/or spark plug cable.
- b. Lubricate grease fittings with one to two pumps of SAE No. 2 multi-purpose gun grease.

<u>Fitting Locations</u>	<u>No. of Places</u>	<u>Service Interval</u>
Front Caster Wheel Bearings	2	Daily
Front Casters	2	Daily
Cutter Housing Spindles	3	25 hrs.
Drive Wheels	2	Daily
Idler Pivots	7	Yearly

- c. Lubricate Low Torque Drive Chain with engine oil or special chain lubricant every 25 hours (or more often when operating in severe conditions).
- d. Lubricate the brake arm pivots with engine oil every 25 hrs.

5.1.14 (Con't)

- e. Check 5-speed gearbox grease level every 150 hours (more often under severe conditions). The grease level should be approximately 1-1/2 - 1-3/4" from the gearbox bottom. Fill to proper level with Peerless (Part No. 788067) grease.
- f. Replace 5-speed gearbox grease yearly. Use 24 ounces of Peerless P/N 788067.

5.1.15 Remove engine shrouds and clean cooling fins.
Service Interval: See Engine Owner's Manual

- a. Stop engine and remove ignition key and/or spark plug cable.
- b. Remove cooling shrouds from engine and clean cooling fins. Also clean dust, dirt and oil from external surfaces of engine which can cause improper cooling.
- c. Make sure cooling shrouds are properly reinstalled. Operating the engine without cooling shrouds will cause engine damage due to overheating.

5.1.16 Check spark plugs.
Service Interval: 100 hrs.

- a. Remove spark plugs, check condition and adjust plug gap or replace with new plugs. See Engine Owner's Manual.

5.1.17 Change fuel filter.
Service Interval: As Required

- a. A fuel filter is installed in the fuel line between the fuel tank and the engine. Replace when necessary.

5.1.18 Refer to the engine operators manual for detailed maintenance required.

5.2 Adjustments

5.2.1 Cutting height and antiscalp roller adjustment.

 **CAUTION: FRONT END OF SUPPORT FRAME MAY RISE UP SUDDENLY IF NOT HELD DOWN SECURELY WHEN THE FRONT TWO DECK SUPPORT ROD HAIRPINS ARE REMOVED.**



CUTTING HEIGHT ADJUSTMENT

5.2.1 (Con't)

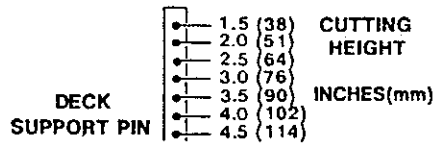

a. Install hairpin clips in the holes shown on above sketch for the desired cutting height.

b. For maximum deck floatation, place rollers in position shown on sketch. Roller should maintain 1/4 in. (6.4 mm) clearance to ground. Do not adjust rollers to support the deck. Be sure locking nut is properly torqued or loss of antiscalp roller may result.

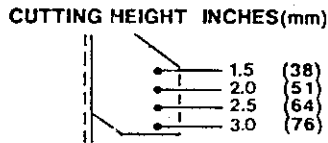

5.2.2 Transmission drive belt tension adjustment - No adjustment necessary.

5.2.3 Cutter deck drive belt. No adjustment necessary.

5.2.4 Blade drive belt tension. No adjustment necessary.

5.2.5 Brake adjustment - see 3.2.8.

5.2.6 Wheel drive linkage adjustment - see 3.2.7

5.2.7 Forward Tracking - If mower does not track straight check the following:

- a. Check idler arm pulleys and drive sheaves for mud and/or grass buildup. Check for proper scrapper position.
- b. Check to be sure idler arms pivot freely, if not disassemble and grease idler pivots.
- c. Check for worn drive belts.

NOTE: Wheel drive belts should be replaced as a set. A new belt should not be mixed with a worn belt.

- d. Check drive linkage adjustment - See 3.2.7.
- e. Check for proper tire pressure in drive tires. Recommended tire pressure for the drive tires is 12-14 psi. If tire pressures are equal and the mower still pulls to the left or right, increase pressure in the tire (up to 14 psi 97kPa) on the side it pulls to and/or reduce the pressure in the tire on the opposite side until the mower runs straight on a level surface.

5.2.8 Low Torque Drive Chain Tension - Check the drive chain to see if it needs tightening. See 5.1.10. If chain needs tightening, loosen transmission mounting bolts under rear deck, remove transmission belt, then slide transmission toward the rear of the deck until chain is properly tensioned as outlined in 5.1.10. Retighten transmission, tightening rear bolts first, then front two bolts and replace transmission belt.

5.2.9 Low Torque Drive Sprocket Alignment - Proper alignment of jackshaft and transmission sprockets will reduce chain wear and possible jackshaft or transmission failures.

- a. See 5.1.12
- b. Make sure the jackshaft is centered. To adjust, measure the distance between the inside of the posi-trac drive pulleys and the outside surface of the tank/handle support plate (see Figure 9). Do this for both sides (two pulleys). Before taking this measurement, make sure the posi-trac pulleys are snug up against the jackshaft shoulder (if they are not, adjust them and retighten setscrews). This measurement should be approximately 1-1/4" on both sides and should be within 1/16" of each other. If no adjustment is required, check the bearing lock collars and setscrews (make sure they are tight). If adjustment is necessary, loosen the setscrews and lock collars of the jackshaft bearings. Remove the left and right fenders. Tap one end or the other of the jackshaft until the measurement is equal between the inside of the pulley and the surface of the support plate on both sides. Tighten the bearing lock collars and setscrews and replace the fenders.
- c. Recheck the sprocket alignment as per 5.1.12. If no further adjustment is necessary, make sure jackshaft sprocket setscrew is tight. If further adjustment is required, proceed to next step.
- d. If realignment is necessary, loosen the jackshaft sprocket setscrew. Using a 6" straight edge as per 5.1.12, slide the sprocket until it is within the 1/16" allowable range to left or right of the transmission matching left surface of sprockets. See Figure 9. Resecure the sprocket setscrew and replace the chain guard.

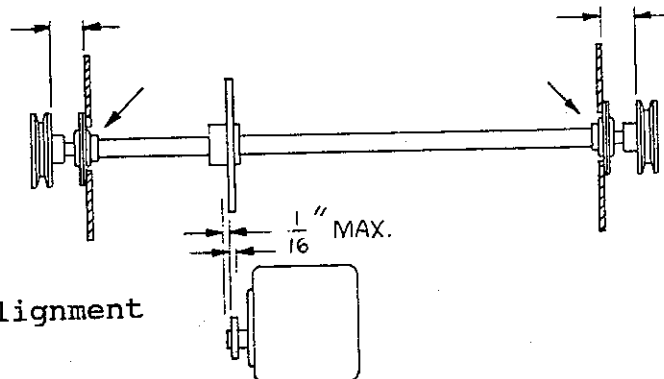

Fig. 9 Low Torque Drive Sprocket Alignment

5.2.10 Electric Clutch Adjustment

- a. Stop engine and remove ignition key and/or spark plug cable.
- b. Shift transmission into gear and engage drive levers.
- c. Locate the three "windows" or "notches" where the air gap is checked (see Figure 10.)
- d. With feeler guage check gap at all three locations.
- e. Factory air gap setting is .005"-.020".
- f. If gap doesn't fall between .005"-.020", then reset using a .012" feeler guage.
- g. Changing the air-gap is achieved by tightening and/or loosening the three nuts.

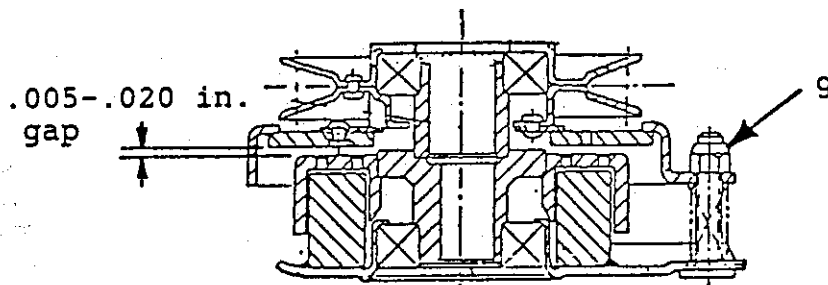

Fig. 10 Electric Clutch Adjustment

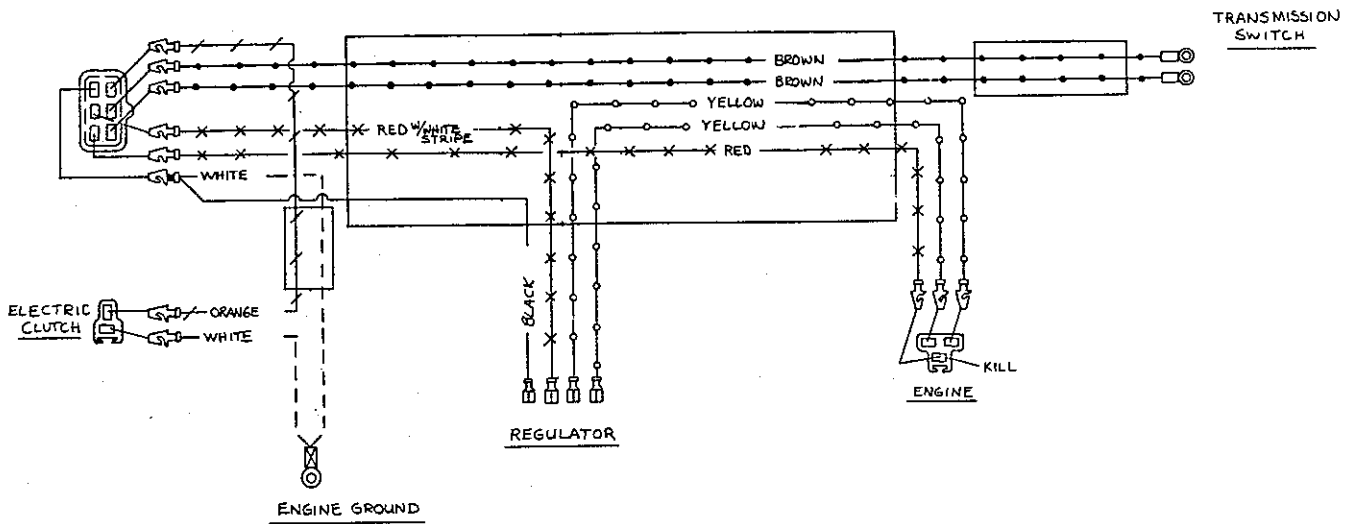

Fig. 13 Engine Deck Wiring Diagram (14 hp Kaw.)
 (NOTE: All connectors are viewed from the wire input side of the connectors.)

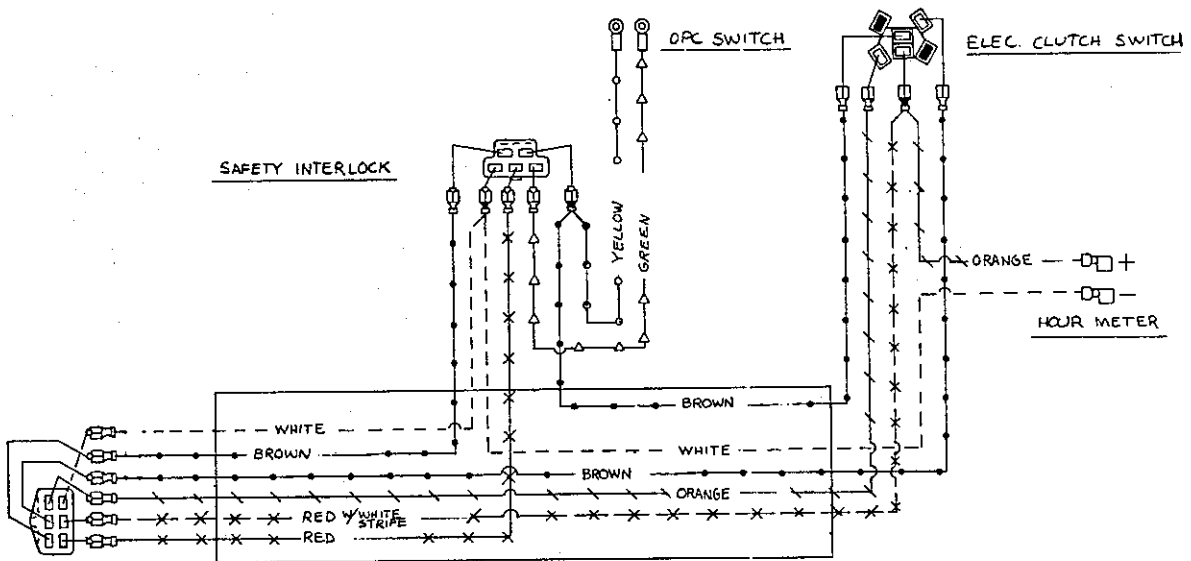

Fig. 14 Console Wiring Diagram (14 hp Kaw.)
 (NOTE: All connectors are viewed from the wire input side of the connectors.)

EXMARK MFG. CO., INC.
INDUSTRIAL PARK BOX 748
402/223-4010

PART # 850137
BEATRICE, NE 68310
FAX 402/223-4154

ALL RIGHTS RESERVED 1988 PRINTED IN U.S.A.

