

For Serial Nos.  
670,000 & Higher

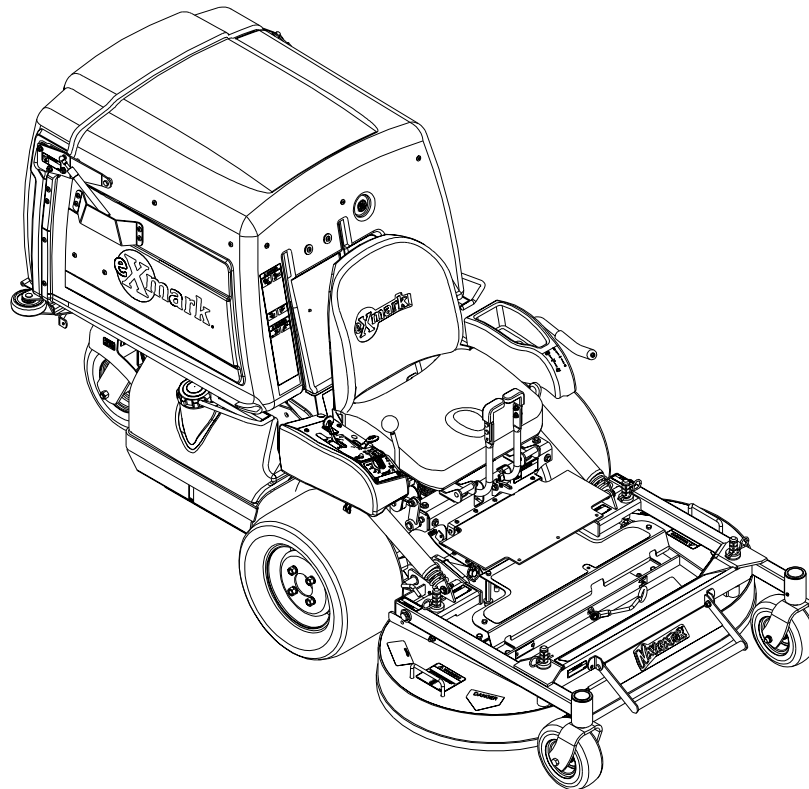

PARTS MANUAL

# NAVIGATOR

CONGRATULATIONS on the purchase of your new Exmark mower. This product has been carefully designed and manufactured to give you a maximum amount of dependability and years of trouble-free operation. If additional information is needed, or should you require trained mechanic service, contact your authorized Exmark equipment dealer or distributor. If you need to order replacement parts from your dealer, always give the model number and serial number of your mower as well as the part number, description and quantity of the part needed.

The Serial No. Plate located at the rear of the machine under the hopper adjacent to the rear castor pivot. For ease of ordering and reference, we suggest that you record the information requested in the following identification table

Place Model No. and Serial No. Label Here  
(Included in Literature Pack)  
or Fill in Below

Model No. \_\_\_\_\_

Serial No. \_\_\_\_\_

Engine Model No. and Spec. No. (Code) \_\_\_\_\_

Engine Serial No. (E/No) \_\_\_\_\_

Date Purchased \_\_\_\_\_

# EXMARK PARTS PLUS® PROGRAM

**EFFECTIVE DATE: September 1, 1995**

## Program

If your Exmark dealer does not have the Exmark part in stock, Exmark will get the parts to the dealer the next business day or the part will be FREE\* Guaranteed!!

## **How the Program Works**

1. If dealer does not have part in stock for a "down" unit at the time of request by customer, the dealer contacts his distributor by 1:00 p.m., local time, and requests Exmark Parts Plus® shipment of six (6) line items or less.
2. Distributor ships part(s) to dealer or customer, as requested by dealer, same day, overnight UPS. Distributor bills dealer for part and freight charges where applicable.
3. If distributor does not have the part(s) in stock to satisfy Exmark Parts Plus® order, he contacts Exmark by 3:00p.m., central time, with an Exmark Parts Plus® order of six (6) line items or less.
4. If order is received by 3:00 p.m. central time, Exmark ships part(s) direct to dealer or customer, as requested by distributor, same day, overnight UPS, Exmark bills the distributor for parts and shipping charges, where applicable.
5. The customer pays for the part and freight if it is shipped under the Exmark Parts Plus® and if it arrives in accordance to the program.
6. Who pays for the part and freight if it fails to arrive overnight in accordance to the program?
  - A. Under any circumstance the customer does not pay.
  - B. If the part does not arrive overnight due to:
    1. The dealer not submitting the Exmark Parts Plus® order to his Exmark distributor by 1:00 p.m., the dealer pays for the part and freight.
    2. The Distributor being unable to ship the part the same day or not submitting the Exmark Parts Plus® order to Exmark by 3:00 p.m., central time, the Distributor pays for the part and freight.
    3. Exmark being unable to ship the part and the Exmark parts order is received by 3:00 p.m., central time, Exmark pays for the part and freight.
    4. If the part does not arrive overnight due to the shipper (UPS), the shipper pays for the freight and Exmark pays for the part.

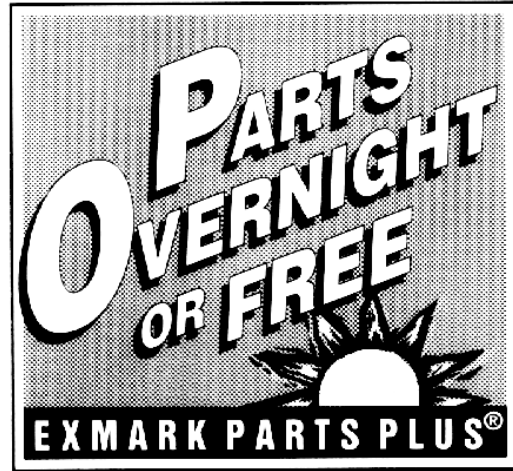

**The following restrictions apply** -- The Exmark Parts Plus® Program is available only through participating Exmark Dealers and applies only to orders submitted on this program Monday through Thursday. Parts Plus service is available only in the 48 contiguous United States. UPS has initiated a Saturday delivery program to many areas of the continental United States and can be requested for an overnight shipment on Friday to be delivered Saturday. The next day air charge, plus the Saturday delivery fee will be the responsibility of the purchaser. Exmark Mfg. will assume no responsibility for Saturday delivery shipments. To qualify, all Exmark Parts Plus® orders must be received by Exmark by 3:00 p.m., central time. Orders must be six (6) line items or less. Exclusions from the Exmark Parts Plus® Program are: Any wholegood or accessory in its entirety, engines and engine replacement parts, 5-speed Peerless transmissions and 5-speed transaxles, hydraulic or hydrostatic wheel motors, cutter decks and engine decks or any item exceeding United Parcel Service size and weight restrictions.

Due to UPS restrictions, aerosol spray paint is considered a hazardous material and cannot be shipped via UPS next day or Second Day Air.

Exmark Manufacturing stocks a limited supply of parts for transaxles, pumps and wheel motors. These parts can be ordered for Next Day Air shipment but will not be guaranteed per the Parts Plus Program

**READ OPERATOR'S MANUAL BEFORE  
OPERATING OR SERVICING EXMARK EQUIPMENT.**

**TABLE OF CONTENTS**

<b><u>Description</u></b>	<b><u>Page</u></b>
Blower Group.....	10
Decals Group.....	25
Electrical Diagram .....	23
Electrical Logic Schematic.....	24
Electrical Group.....	21-22
Engine Group .....	13-14
Fuel Group.....	9
Hopper Group.....	17-20
Hydraulic Group.....	15-16
Jackshaft Group .....	11-12
Main frame Group.....	3-5
Park Brake Group.....	6
Speed Controls Group .....	7-8

## MAIN FRAME GROUP

Item	Part No.	Description	Qty.
1	103-8383	Bolt, Seat Cushion .....	5
2	1-633060	Spacer .....	2
3	1-633396	Clip, Loom 5/8.....	1
4	1-633508	Washer, Spring Disk .....	6
5	1-633585	Bearing, Cone Tapered Roller.....	2
6	103-9483	Asm, Seat Frame W/Decal .....	1
7	1-807513	Bolt, Carriage #10-24 x 1/2 .....	4
8	5-0652	Spacer .....	4
9	103-0063	Seal, Double Lip.....	2
10	103-2768	Guard, Seal.....	2
11▲	103-3051	Spacer, Nut.....	2
12	103-3351-03	Wld, Rear Caster Fork .....	1
13	103-3520	Seat, Back .....	1
14	109-2008	Seat, Bottom.....	1
15	109-4306	Asm, Mainframe W/Decals .....	1
16	103-4155	Pin, Lynch.....	2
17	103-4318	Wheel .....	2
18	1-303287	Tie, Cable 5 1/2 (Small) .....	4
19	103-4362-03	Wld, Seat Frame Std .....	1
20	109-4641	Cable, Control Throttle.....	1
21	103-5181	Link, Lower Seat Stop.....	1
22	103-5302	Axle, Caster .....	1
23	103-5496	Mount, Vibration Rubber .....	4
24	103-6596-03	Wld, Push Rod.....	2
25	103-7738	Screw, HH 1/2-13 x 13.....	1
26	103-8143	Console, RH .....	1
27	103-8146	Console, LH.....	1
28	109-4639	Asm, Control Panel W/Decals.....	1
29	103-8451	Decal, Ignition/Speed Control.....	1
30	103-8563	Link, Seat.....	1

Item	Part No.	Description	Qty.
31	109-4638	Decal, Console .....	1
32	103-9027	Seal, Grease.....	1
33	103-9028	Cone, Bearing Taper Roller .....	2
34	103-9029	Cup, Bearing Tapered Roller .....	2
35	103-9032	Decal, Service Aid .....	1
36	103-9034	Decal, Clutch Adjustment .....	1
37	103-9057	Cap, Grease .....	1
38	242-50	Nut, Lug 1/2-20.....	8
39	322-2	Screw, HH 5/16-18 x 5/8.....	6
40	322-5	Screw, HH 5/16-18 x 1 .....	3
41	323-14	Screw, HH 3/8-16 x 3.....	2
42	325-17	Screw, HH 1/2-13 x 4.....	2
43	3231-27	Bolt, Carriage 3/8-16 x 7/8 .....	1
44	3256-23	Washer, 5/16 SAE .....	6
45	3256-8	Washer.....	1
46	3296-2	Nut, Nyloc #10-24.....	4
47	3296-23	Nut, Nyloc 1/2-13 .....	1
48	3296-29	Nut, Nyloc 5/16-18.....	3
49	3296-39	Nut, Nyloc 3/8-16.....	3
50	3296-51	Nut, Nyloc 3/4-10.....	1
51	103-5305	Asm, Wheel Tire & Brg 13x8.00-6 SP....	1
52	32128-20	Nut, Whizlock 5/16-18 .....	8
53	32128-49	Nut, Whizlock 1/2-13 .....	2
54	109-2006	Asm, Seat W/Decal .....	1
55	103-9494	Asm, Rear Caster Wheel W/Axle.....	1
56	109-4640	Cable, Control Choke .....	1
57	103-4319	Asm, Wheel & Tire 18 x 10.50-10.....	2
	103-4321	Asm, Wheel & Tire 18 x 8.50-10.....	2
58	105-1945	Tire, 18 X 10.5-10 .....	2
	103-4320	Tire, 18 X 8.50-10 .....	2

Exmark black touch up spray paint – Gloss black

▲ Use Pro-Lock, Nut Type (P/N 1-840022, .5ml tube) on spacer nut, item #11.

# MAIN FRAME GROUP

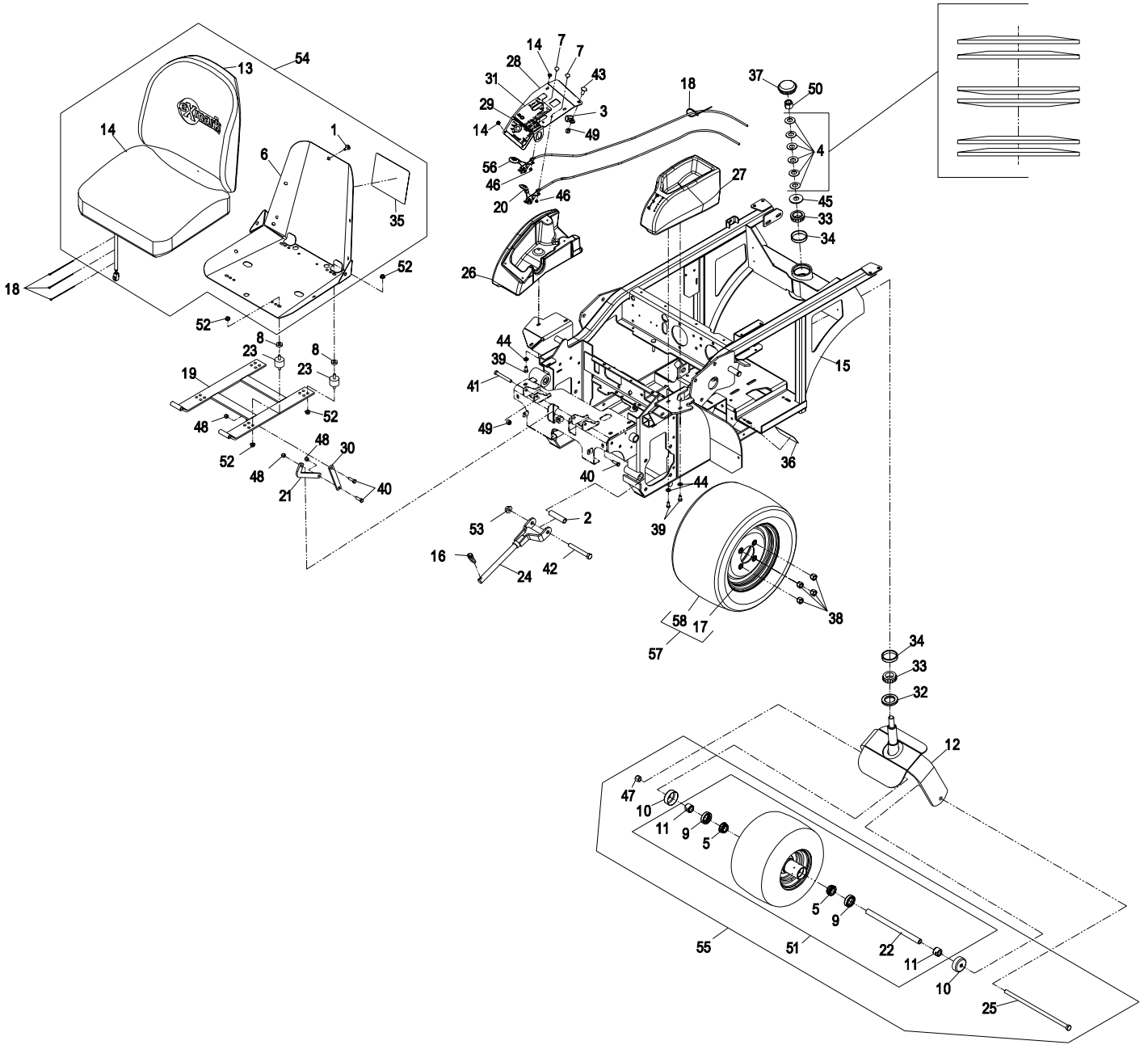

## MAINFRAME GROUP (cont.)

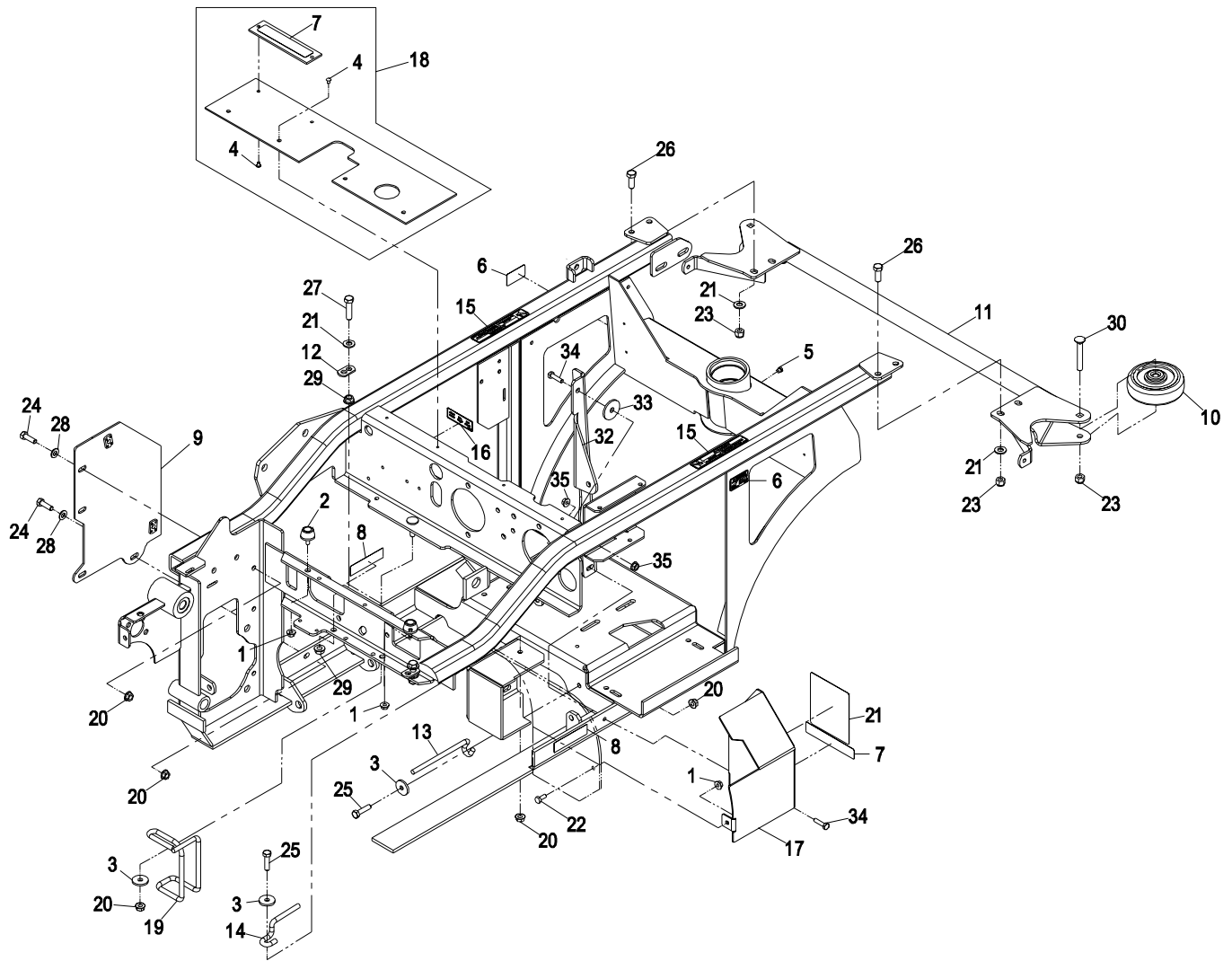

Item	Part No.	Description	Qty.
1	32128-33	Nut, Whizlock 1/4-20.....	5
2	109-2365	Bumper.....	2
3	1-613235	Washer.....	3
4	1-803035	Rivet 3/16 x 1/4.....	6
5	1-811010	Plug.....	1
6	65-2690	Decal, Hot Surface.....	2
7	98-4361	Decal, Warning.....	2
8	98-5954	Decal, Danger.....	2
9	109-2487-03	Wld, Fender.....	1
10	103-5408	Wheel.....	2
11	109-0925-03	Wld, Bumper Rear.....	1
12	103-6537	Tab, Spring Anchor.....	2
13	103-8333	Guide, Belt.....	1
14	103-8349	Guide, Belt.....	1
15	103-8495	Decal, Pinch Point.....	2
16	103-8611	Decal, Relay.....	1
17	103-9475	Asm Drive, Shield.....	1
18	103-9476	Asm, Shield W/Decal.....	1

Item	Part No.	Description	Qty.
19	103-9022	Guide, Belt.....	1
20	32128-20	Nut, Whizlock 5/16-18.....	7
21	103-9274	Decal, Belt Routings.....	1
22	321-3	Screw, HH 1/4-20 x 5/8.....	1
23	3296-39	Nut, Nyloc 3/8-16.....	6
24	322-5	Screw, HH 5/16-18 x 1.....	4
25	322-6	Screw, HH 5/16-18 x 1 1/4.....	2
26	323-6	Screw, HH 3/8-16 x 1.....	4
27	323-8	Screw, HH 3/8-16 x 1 1/2.....	2
28	3256-23	Washer, 5/16 SAE.....	4
29	3290-357	Nut, Whizlock 3/8-16.....	4
30	3231-31	Bolt, Carriage 3/8-16 x 2 1/2.....	2
31	3256-24	Washer, 3/8 SAE.....	6
32	109-5874-03	Brace, PTO.....	1
33	1-213069	Spacer.....	1
34	321-6	Screw, HH 1/4-20 x 1.....	2
35	32128-33	Nut, Whizlock 1/4-20.....	5

Exmark black touch up spray paint – Gloss black

# PARK BRAKE GROUP

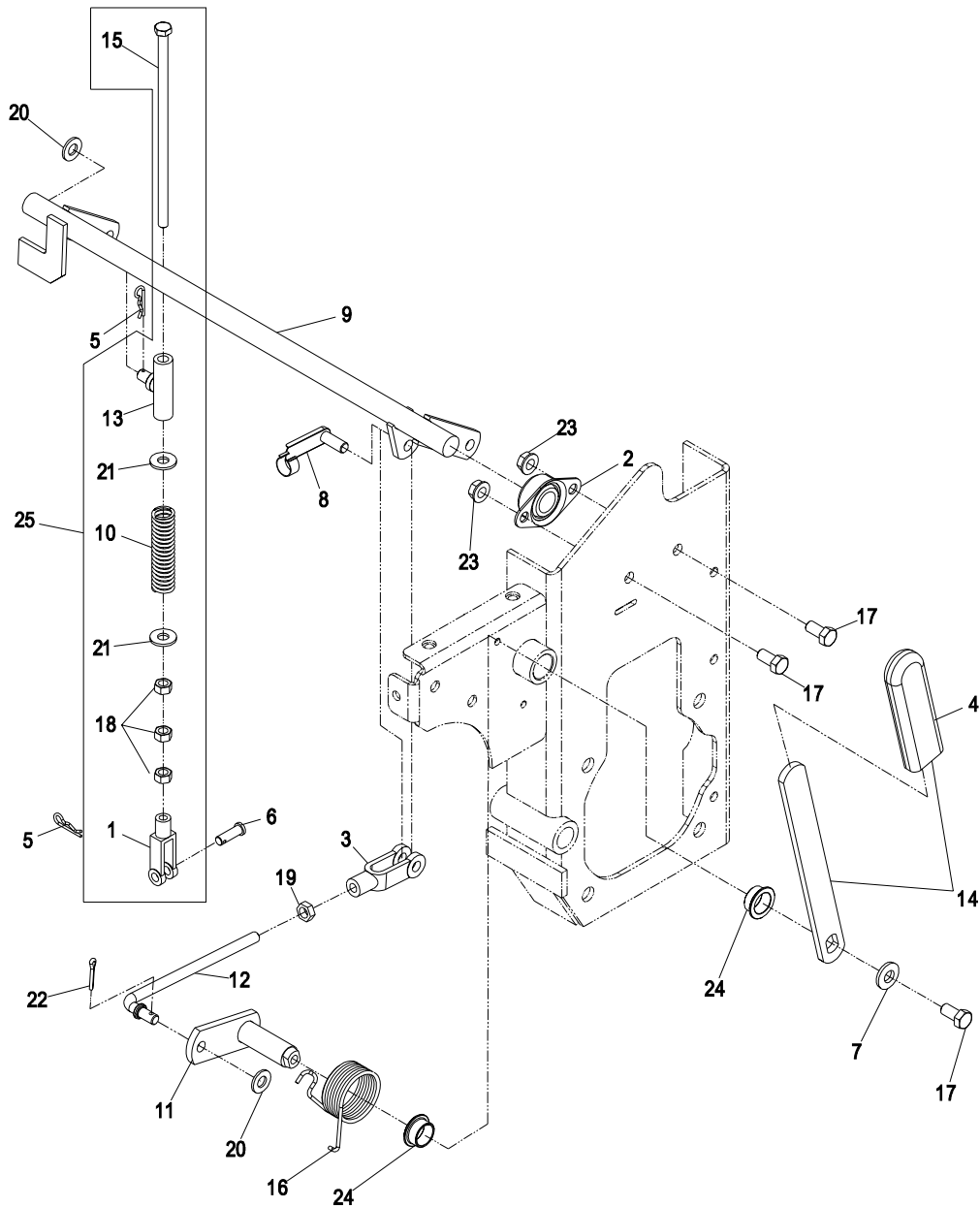

Item	Part No.	Description	Qty.
1	1-303105	Yoke, Adjustable .....	2
2	1-633102	Bearing, Side Flange .....	2
3	1-633131	Yoke, Brake Linkage.....	1
4	1-633268	Grip, Brake Lever.....	1
5	1-806003	Hairpin, Cotter.....	4
6	1-808280	Pin, Clevis 5/16 x 1 .....	2
7	98-5975	Washer, Spring Disk 3/8 .....	1
8	103-2399	Pin, Clevis Spring 3/8.....	1
9	103-4383-03	Wld, Brakeshaft .....	1
10	103-4388	Spring, Brake .....	2
11	103-4390	Wld, Brake Pivot .....	1
12	103-4399	Rod, Linkage Brake .....	1
13	103-6576	Wld, Swivel Brake.....	2

Item	Part No.	Description	Qty.
14	103-9469	Asm, Park Brake Handle W/Grip .....	1
15	103-7377	Screw, HH 5/16-24 x 7 3/4.....	2
16	103-9915	Spring, Torsion RH .....	1
17	323-4	Screw, HH 3/8-16 x 3/4.....	5
18	3219-2	Nut, Hex 5/16-24.....	6
19	3219-3	Nut, Hex 3/8-24.....	1
20	3256-24	Washer, 3/8 SAE.....	3
21	3256-3	Washer, 5/16 Std.....	4
22	3272-10	Pin, Cotter 1/8 x 3/4.....	1
23	3290-357	Nut, Whizlock 3/8-16 .....	4
24	108519	Bushing, Bronze .....	2
25	109-0714	Asm, Brake Linkage .....	2

Exmark black touch up spray paint – Gloss black

## SPEED CONTROLS GROUP

Item	Part No.	Description	Qty.
1	1-543017	Ball Joint, (RH).....	3
2	1-633102	Bearing, Side Flange .....	2
3	1-633152	Ball Joint, (LH) .....	3
4	1-804524	Nut, Hex 5/16-24 (LH) .....	5
5	1-811010	Plug .....	4
6	103-3060	Knob, Tracking.....	1
7	103-9468	Asm, Handle W/Grip .....	2
8	103-9730	Asm, Steering Lever W/Bearings (RH)...	1
9	103-9731	Asm, Actuator W/Bearings (RH) .....	1
10	103-9732	Asm, Actuator W/Bearings (LH).....	1
11	103-4278	Shaft, Speed Control.....	1
12	103-4342-03	Wld, Hub Speed Control .....	2
13	103-4373	Spring, Extension.....	2
14	103-4377	Linkage, Rod Steering (LH).....	2
15	103-4397	Knob, Speed Control.....	1
16	103-4398	Bearing, Flange Iglide .....	8
17	103-9733	Asm, Steering Lever W/Bearings (LH) .....	1
18	103-5008	Wld, Control Arm .....	1
19	103-5009	Disc, Friction.....	2
20	103-5013	Wld, Speed Control Lever.....	1
21	103-5016	Rod, Threaded Control Link .....	1
22	103-5017	Plate, Speed Control Friction .....	1
23	103-5018	Washer, Spring Disk .....	3
24	103-5064	Bearing, Plastic 1/2.....	2
25	109-5927	Asm, Console W/Decals .....	1
26	103-5945	Spacer .....	1
27	103-5993-03	Guide, Plenum .....	1
28	103-6078	Spring, Extension.....	1
29	103-6532	Spring, Extension.....	2
30	103-8494	Hook .....	1

Item	Part No.	Description	Qty.
31	321-5	Screw, HH 1/4-20 x 7/8.....	4
32	321-8	Screw, HH 1/4-20 x 1 1/4.....	1
33	322-3	Screw, HH 5/16-18 x 3/4.....	6
34	322-6	Screw, HH 5/16-18 x 1 1/4.....	6
35	323-4	Screw, HH 3/8-16 x 3/4.....	4
36	323-8	Screw, HH 3/8-16 x 1 1/2.....	2
37	322-5	Screw, HH 5/16-18 x 1 .....	1
38	3217-6	Nut, Hex 5/16-18.....	2
39	3218-3	Nut, Jam 3/8-16.....	1
40	3219-2	Nut, Hex 5/16-24.....	4
41	3245-1	Setscrew, 1/4-20 x 1/4 .....	6
42	3256-23	Washer, 5/16 SAE .....	3
43	3256-24	Washer, 3/8 SAE .....	2
44	3256-28	Washer, 3/4 SAE .....	1
45	3256-3	Washer, 5/16 Std.....	9
46	3257-5	Key, Woodruff #9 3/4 x 3/16 .....	3
47	3290-357	Nut, Whizlock 3/8-16 .....	8
48	3296-19	Nut, Nyloc 1/2-20 .....	1
49	3296-29	Nut, Nyloc 5/16-18 .....	7
50	32128-20	Nut, Whizlock 5/16-18 .....	1
51	32128-33	Nut, Whizlock 1/4-20 .....	6
52	32151-48	E-Ring .....	1
53	1-323245	Spring, Compression .....	4
54	103-5994	Grip, Steering Handle .....	2
55	103-9468	Asm, Handle W/Grip.....	2
56	103-8425	Decal, Driveline .....	1
57	103-9493	Asm, Pump Linkage (RH) .....	1
58	103-9492	Asm, Pump Linkage (LH).....	1
59	109-4273	Decal, Wheel Motor Release .....	1

Exmark black touch up spray paint – Gloss black.



# SPEED CONTROLS GROUP

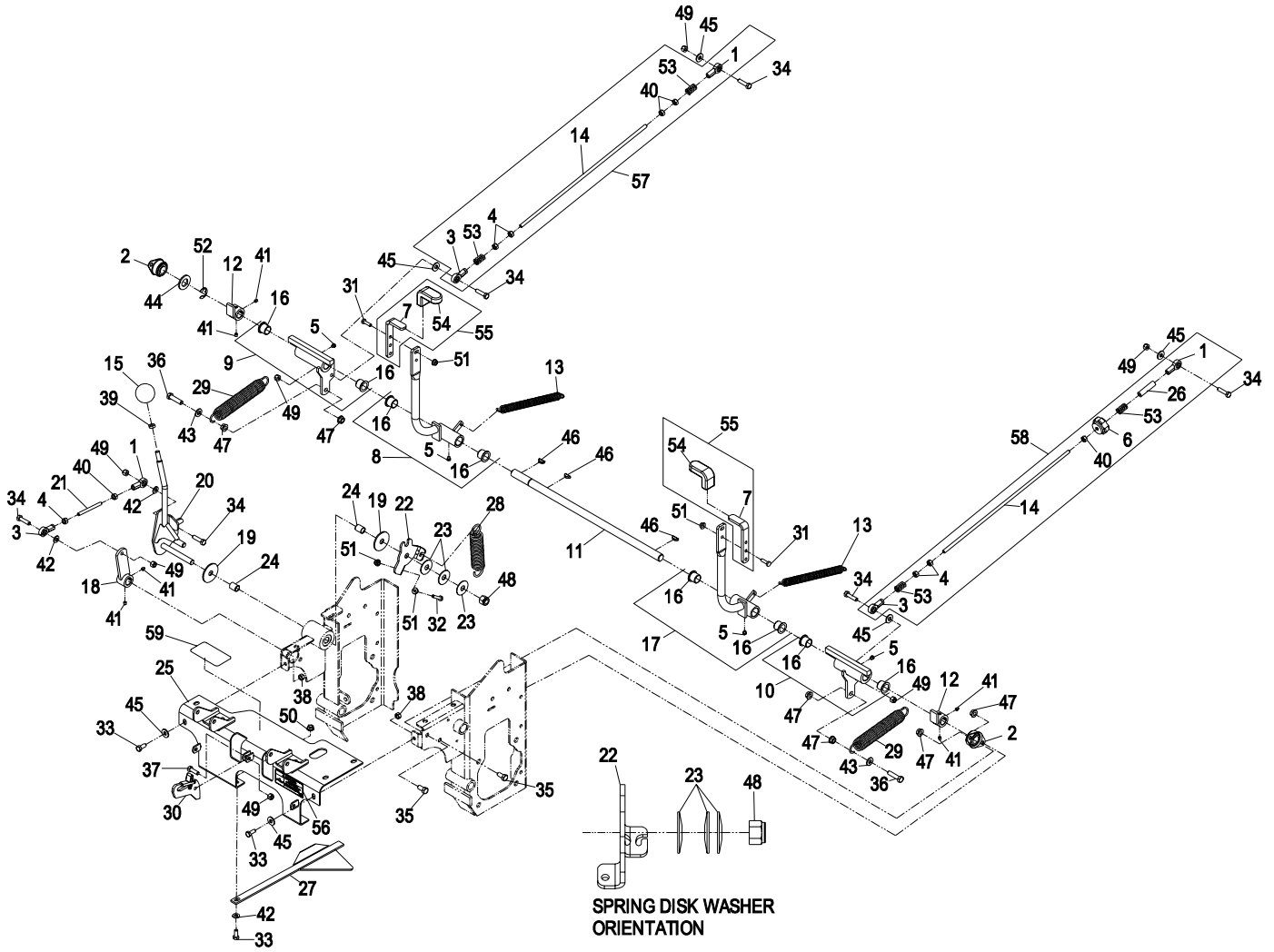

# FUEL GROUP

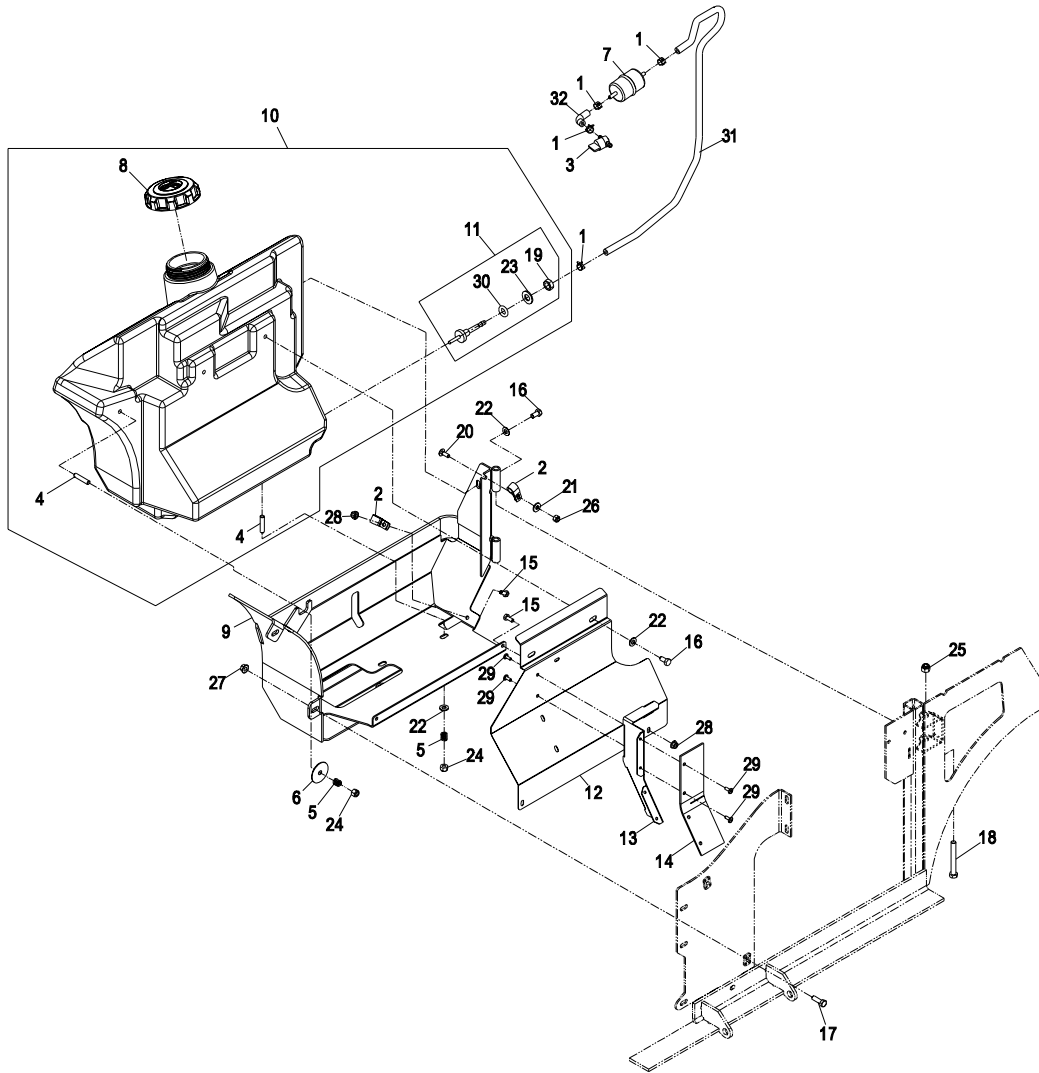

Item	Part No.	Description	Qty.
1	1-303077	Clamp-Line, Fuel.....	4
2	1-513762	Clip, Loom 1/2.....	2
3	1-603770	Valve, Fuel.....	1
4■	1-633023	Stud, Fuel Tank .....	3
5	1-633349	Spring, Compression .....	3
6	1-653036	Washer .....	1
7‡	<b>Kohler</b>	Part No. 2405010 Fuel Filter .....	1
8	109-0346	Cap, Fuel.....	1
9	103-5765-03	Wld, Tank Frame.....	1
10	109-2957	Asm, Tank Fuel.....	1
11▲	103-6057	Fitting, Fuel Bulkhead W/Screen.....	1
12	109-5344-03	Panel, Tank Shield.....	1
13	103-7095-03	Deflector, Air (27 HP only) .....	1
14	103-9658	Flap, Rubber (27 HP only).....	1
15	321-3	Screw, HH 1/4-20 x 5/8 .....	3
16	322-2	Screw, HH 5/16-18 x 5/8 .....	3

Item	Part No.	Description	Qty.
17■	322-5	Screw, HH 5/16-18 x 1 .....	2
18	323-14	Screw, HH 3/8-16 x 3.....	2
19	3220-5	Nut, Jam 1/2-20.....	1
20	3229-1	Bolt, Carriage 1/4-20 x 3/4 .....	1
21	3256-2	Washer, 1/4 Std.....	1
22	3256-23	Washer, 5/16 SAE .....	5
23	3256-26	Washer, 1/2 SAE .....	1
24	3296-47	Nut, Nyloc 5/16-18 Thin .....	3
25	3296-39	Nut, Nyloc 3/8-16.....	2
26	3296-42	Nut, Nyloc 1/4-20.....	1
27	32128-20	Nut, Whizlock 5/16-18 .....	2
28	32128-33	Nut, Whizlock 1/4-20 .....	3
29	114439	Rivet (27 HP only).....	9
30	103-2784	O-Ring .....	1
31	109-0284	Hose, Fuel Line 29" .....	1
32	109-0304	Hose, Fuel Line 2 1/2" .....	1

Exmark black touch up spray paint – Gloss black

■ Use Pro-Lock, Retaining Type (P/N 1-840023, .5ml tube) on stud threads, item #4 going into tank and on threads at the head of screw, item #17.

▲ Use Pro-Lock, Nut Type (P/N 1-840022, .5ml tube) on fuel fitting, item #11.

‡ Refer to Engine Owner's Manual (Fuel Filter **Must** be 15 Micron or smaller).

# BLOWER GROUP

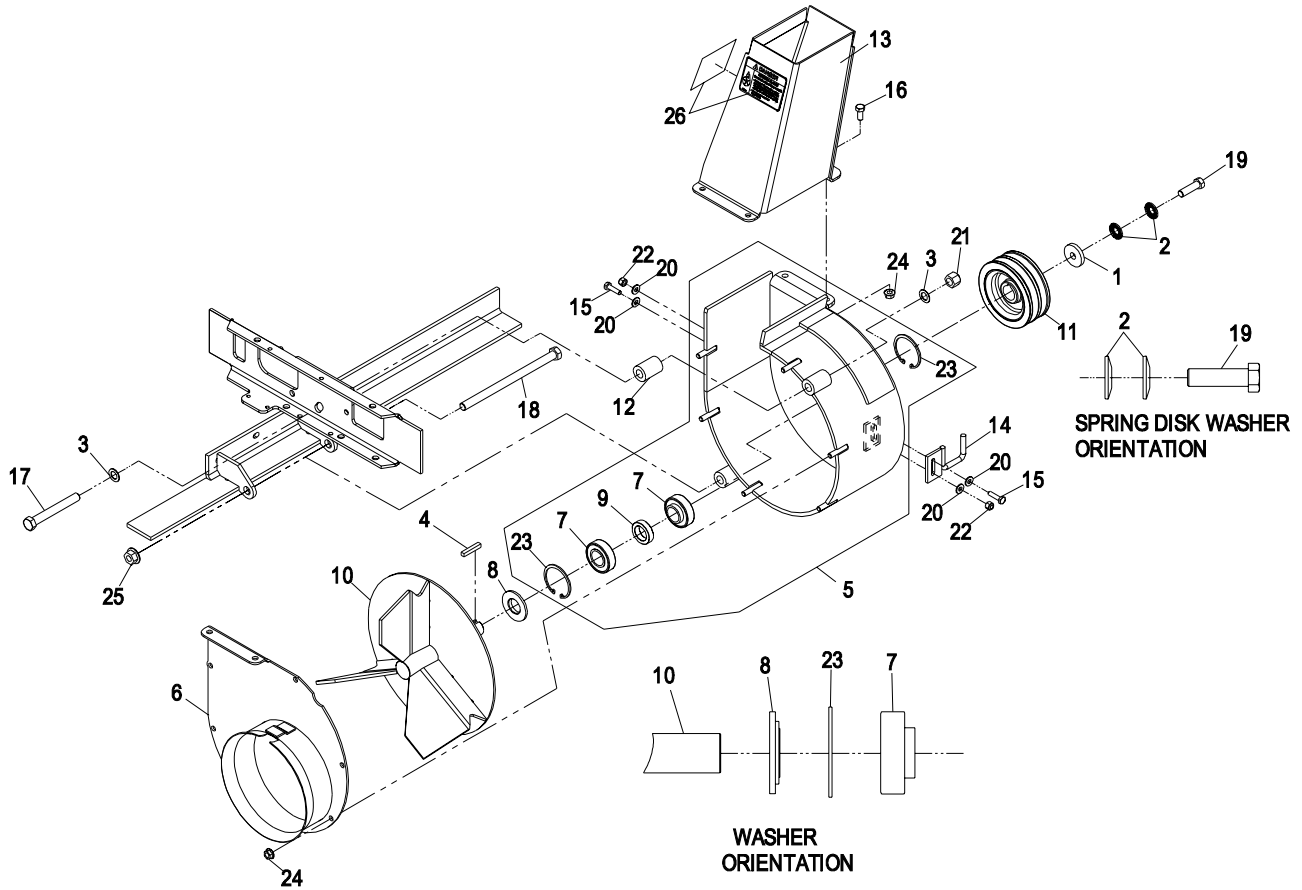

Item	Part No.	Description	Qty.
1	1-543610	Washer .....	1
2	1-603610	Washer, Spring Disk 7/16 .....	2
3	18-9810	Washer, Thrust .....	2
4	67-7490	Key, Machine 1/4 x 1/4 x 1 1/2 .....	1
5	109-0183	Asm, Blower Housing W/Brgs .....	1
6	103-3370-03	Wld, Blower Cover Assembly .....	1
7	103-3540	Bearing, Ball .....	2
8	103-3894	Spacer, Blower .....	1
9	103-4921	Spacer, Bearing .....	1
10	103-5194	Wld, Impeller .....	1
11	103-6733	Sheave, Blower .....	1
12	103-6999	Spacer, Mount .....	1
13	103-9474	Asm, Discharge Chute W/Decal .....	1
14	103-9167-03	Wld, Guide .....	1

Item	Part No.	Description	Qty.
15	321-6	Screw, HH 1/4-20 x 1 .....	2
16	322-3	Screw, HH 5/16-18 x 3/4 .....	4
17	325-17	Screw, HH 1/2-13 x 4 .....	1
18	325-42	Screw, HH 1/2-13 x 8 .....	1
19▲	3212-6	Screw, HH 7/16-20 x 1 1/2 .....	1
20	3256-22	Washer, 1/4 SAE .....	4
21	3296-23	Nut, Nyloc 1/2-13 .....	1
22	3296-42	Nut, Nyloc 1/4-20 .....	2
23	32120-8	Ring, Retaining .....	2
24	32128-20	Nut, Whizlock 5/16-18 .....	10
25	32128-49	Nut, Whizlock 1/2-13 .....	1
26	109-7318	Decal, Danger .....	2
27●	109-0184	Asm, Blower Complete .....	1

Exmark black touch up spray paint – Gloss black.

▲ Use Pro-Lock, Nut Type (P/N 1-840022, .5ml tube) on screw, item #19.

● Complete blower assembly contains all items shown except items #11, #14, #20(4), #15(2) and #22(2).

## JACKSHAFT GROUP

Item	Part No.	Description	Qty.
1	1-303007	Washer .....	2
2	1-413088	Spacer .....	1
3	1-543017	Ball Joint (RH).....	1
4	1-543610	Washer .....	1
5	1-603610	Washer, Spring Disk 7/16 .....	2
6	1-806003	Hairpin, Cotter.....	2
7	67-7490	Key, Machine 1/4 x 1/4 x 1 1/2 .....	1
8	92-9025	Spacer .....	2
9	103-6737	Belt, Matched Pair .....	1
10	103-0608	Ball Joint (RH).....	1
11	103-1167	Ball Joint (LH) .....	1
12	103-9486	Asm, PTO Handle W/Grip.....	1
13	109-5491	Belt, Guide.....	1
14	103-2535	Spacer, Guard Bottom .....	1
15	103-2544	Asm, Jackshaft Housing W/Bearings .....	1
16	103-2916	Guard, Top.....	2
17	103-3504	Bearing, Spherical.....	2
18	103-3506	Seal, Single Lip.....	2
19	103-6732	Sheave .....	1
20	103-6735	Jackshaft .....	1
21	103-9439	Asm, Idler Sheave .....	1
22	103-8253	Asm, Idler Pivot.....	1
23	103-9295	Asm, Pivot W/Bushing .....	1
24	103-9297	Asm, Arm W/Bushing .....	1
25	103-7350	Spacer, Idler .....	1
26	103-7382	Bushing.....	1
27	103-9296	Asm, Arm W/Bushing .....	1
28	103-7392	Asm, Link Clutching .....	1
29	103-7393	Linkage, Rod.....	1
30	103-7697	Band, Brake.....	1
31	103-7994	Ball Joint (RH).....	1
32	103-7996	Linkage, PTO Brake Rod .....	1
33	103-7997	Spring, Brake .....	1

Item	Part No.	Description	Qty.
34	103-9486	Asm, PTO Handle W/Grip .....	1
35	103-8254	Bushing, Spring .....	2
36	103-8277	Link, Handle.....	1
37	103-8716-03	Flag, Switch .....	1
38	3256-24	Washer, 3/8 SAE .....	2
39	103-9816	Spacer .....	1
40	106-7159	O-Ring [1.174 x .103].....	2
41	251-347	Bearing, Ball Deep Groove .....	2
42	283-2	Pin, Clevis 3/8 x 1 1/6.....	1
43	302-19	Zerk, 1/4-28 Str.....	1
44	322-3	Screw, HH 5/16-18 x 3/4.....	2
45	322-6	Screw, HH 5/16-18 x 1 1/4.....	1
46	323-12	Screw, HH 3/8-16 x 2 1/2.....	1
47	323-36	Screw, HH 3/8-16 x 7.....	1
48	323-6	Screw, HH 3/8-16 x 1.....	4
49	323-9	Screw, HH 3/8-16 x 1 3/4.....	2
50▲	3212-6	Screw, HH 7/16-20 x 1 1/2.....	1
51	3219-2	Nut, Hex 5/16-24.....	3
52	3219-20	Nut, Hex 3/8-24 LH.....	1
53	3219-3	Nut, Hex 3/8-24.....	2
54	32151-13	Ring, Retaining .....	2
55	98-5975	Washer, Spring Disk 3/8.....	5
56	3296-29	Nut, Nyloc 5/16-18.....	1
57	3296-39	Nut, Nyloc 3/8-16.....	2
58	3296-6	Nut, Nyloc 3/8-24.....	1
59	32120-10	Ring, Retaining .....	2
60	103-8153	Grip, Control Lever .....	1
61	32128-20	Nut, Whizlock 5/16-18 .....	2
62	32128-43	Nut, Whizlock 3/8-16 .....	2
63	32151-48	E-Ring .....	2
64	108519	Bushing, Bronze .....	6
65	109-0148	Spring, Extension.....	1
66	5-0652	Spacer.....	1

Exmark black touch up spray paint - gloss black.

▲ Use Pro-Lock, Nut Type (P/N 1-840022, .5ml tube) on sheave bolt, item #50.

# JACKSHAFT GROUP

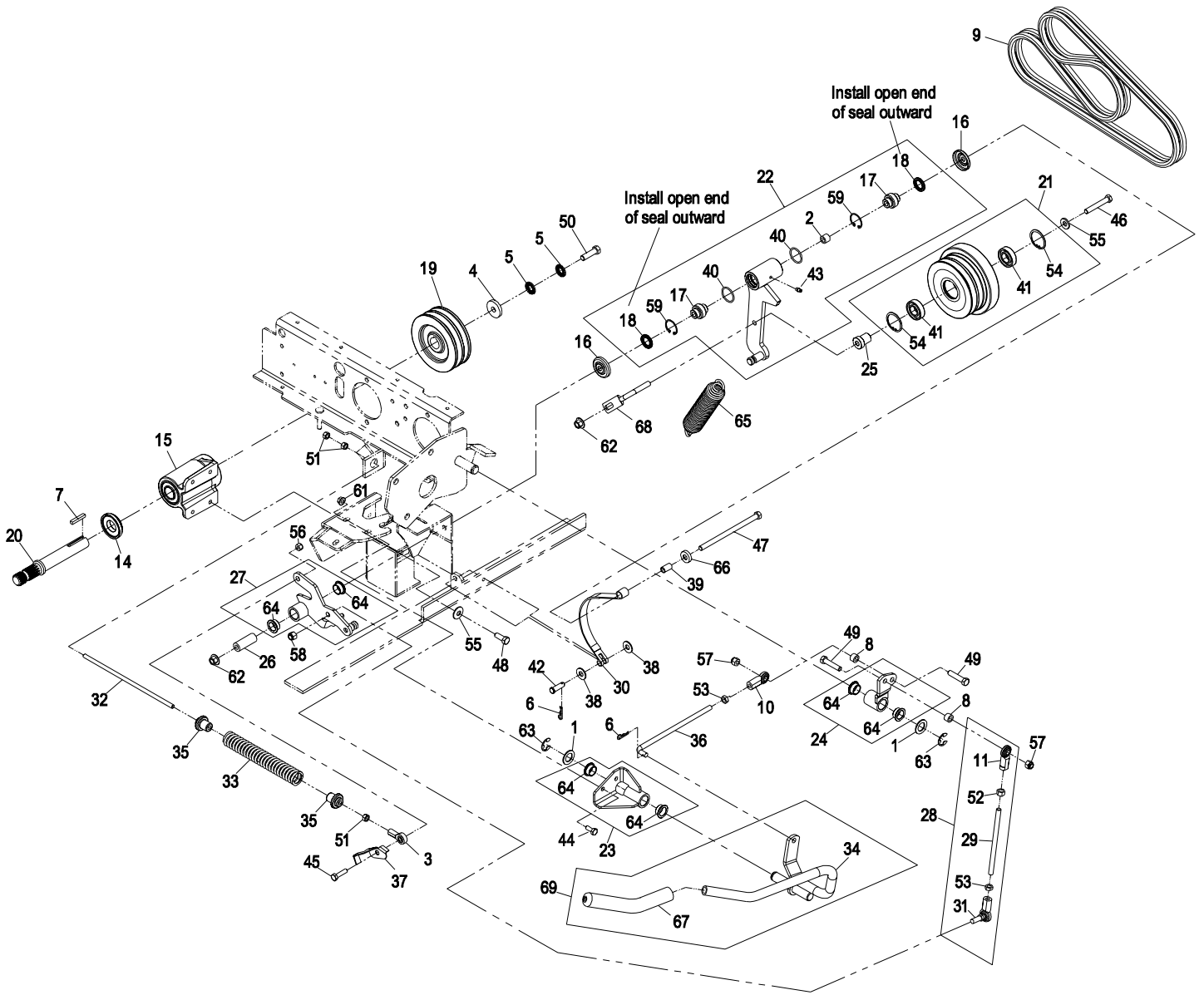

## ENGINE GROUP

Item	Part No.	Description	Qty.
1	32120-10	Ring, Retaining .....	2
2	106-7022	Hose, Oil Drain .....	1
3	323-4	Screw, HH 3/8-16 x 3/4 .....	4
4	1-543610	Washer .....	1
5	1-603610	Washer, Spring Disk 7/16 .....	2
6	1-653291	Gasket, Exhaust Manifold .....	2
7	1-653331	Spring, Extension.....	1
8	1-805005	Washer, Lock 5/16 Heavy.....	4
9	67-7490	Key, Machine 1/4 x 1/4 x 1 1/2 .....	1
10	98-5975	Washer, Spring Disk 3/8 .....	8
11	32128-20	Nut, Whizlock 5/16-18.....	4
12	33014-00	Nut, Hex M8-1.25.....	4
13+	103-1963	Valve, Oil Drain.....	1
14	103-2916	Guard, Top.....	1
15	103-3504	Bearing, Spherical.....	2
16	103-3506	Seal, Single Lip.....	2
17	103-3695-03	Bracket, Air Filter .....	1
18	32128-43	Nut, Whizlock 3/8-16.....	3

Item	Part No.	Description	Qty.
19	109-3492	Pulley, Idler Flat.....	2
20	103-4244	Belt .....	1
21	103-7349	Asm, Short Idler.....	1
22	109-0942	Sheave, Engine .....	1
23	103-6961	Hose, Air Intake.....	1
24	109-3501	Kit, Muffler .....	1
25	109-0181-03	Shield, Exhaust.....	1
26	106-5574	Spacer .....	1
27	106-7159	O-Ring.....	2
28	302-11	Zerk, 45° 1/4-28.....	1
29	322-3	Screw, HH 5/16-18 x 3/4.....	4
30	323-12	Screw, HH 3/8-16 x 2 1/2.....	1
31	323-20	Screw, HH 3/8-16 x 3-1/4.....	1
32	323-9	Screw, HH 3/8-16 x 1 3/4.....	5
33	2412-42	Clamp, Hose.....	2
34▲	3212-6	Screw, HH 7/16-20 x 1 1/2.....	1
35	3256-24	Washer, 3/8 SAE.....	2
36	3290-357	Nut, Whizlock 3/8-16 .....	4

Exmark black touch up spray paint – gloss black.

✚ Use a Teflon Pipe Sealant or equivalent on threads.

▲ Use Pro-Lock, Nut Type (P/N 1-840022, .5ml tube) on sheave screw, item #34.

### **Kohler Replacement Parts List**

(Refer to Engine Owner's Manual)

<u>Description</u>	<u>Kohler Part</u>
Engine Oil Filter.....	5205002
Engine Air Filter.....	2508301
Safety Filter .....	2508304

# ENGINE GROUP

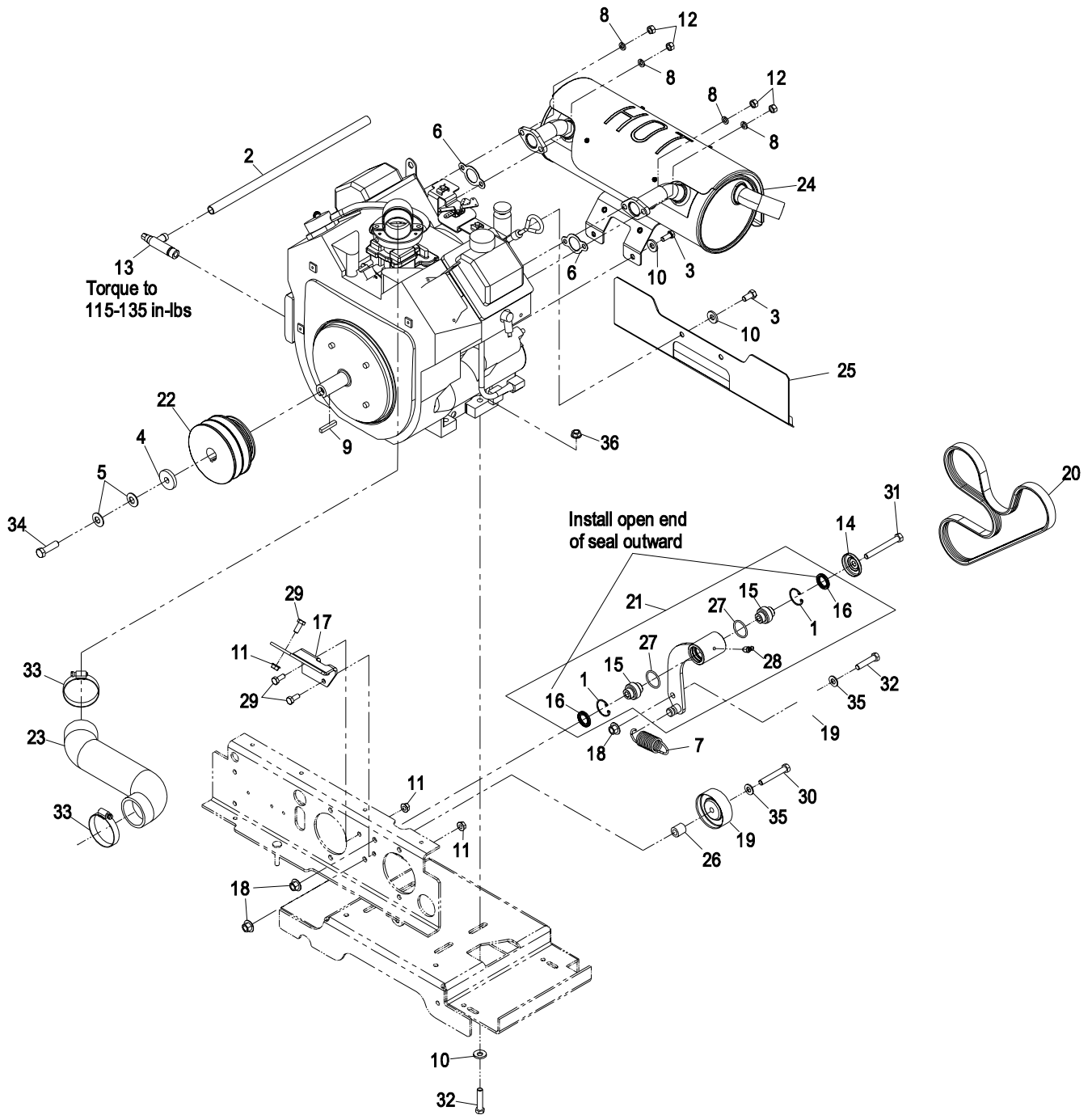

## HYDRAULIC GROUP

Item	Part No.	Description	Qty.
1	1-523552	Decal, Hydraulic Tank .....	1
2	1-543286	Grommet.....	2
3	1-603990	Adapter, Straight.....	8
	1-603920	O-Ring .....	1
	1-603992	O-Ring .....	1
4	1-632208	Arm, Pump Control .....	2
5	1-633396	Clip, Loom 5/8.....	1
6	1-803022	Setscrew, 5/16-18 x 5/8 .....	2
7	1-803310	Setscrew, 5/16-18 x 3/8 .....	4
8	1-805004	Washer, Lock 1/4 Heavy .....	2
9	1-807272	Key, 5mm x 5mm x 25mm .....	2
10	103-1988	Clamp, Hose.....	7
11	103-1828	Adapter, Running Tee.....	1
	1-603921	O-Ring .....	1
12	103-2156	Adapter, Straight.....	5
	1-603921	O-Ring .....	1
	103-1020	O-Ring .....	1
13	103-1947	Asm, Hydraulic Reservoir W/Decal .....	1
14	103-7615	Cap, W/Gasket .....	1
15	103-1949	Gasket, Reservoir Cap.....	1
16●	103-3406	Motor, Wheel (LH).....	1
17	109-7041	Spacer, Wheel Motor.....	8
18	103-4246	Sheave .....	2
19●	103-4612	Motor, Wheel (RH).....	1
20	103-5469	Adapter, Tee Special .....	1
	1-603921	O-Ring .....	1
21■	109-6633	Pump, Hydro.....	2

Item	Part No.	Description	Qty.
22	103-7706	Grommet .....	1
23	103-8631	Bracket, Clamp .....	1
24	109-1258	Hose, Hydraulic .....	1
25	104-7836	Filter, Head.....	1
26	109-4180	Element, Filter 25 Micron.....	1
	⊕ 1-523541	Element, Filter (Winter).....	1
27	321-3	Screw, HH 1/4-20 x 5/8.....	2
28	321-6	Screw, HH 1/4-20 x 1.....	2
29	323-4	Screw, HH 3/8-16 x 3/4.....	2
30	103-5452	Hose, Hydraulic .....	1
31	323-7	Screw, HH 3/8-16 x 1 1/4.....	4
32	325-22	Screw, HH 1/2-13 x 5 1/2.....	8
33	100-4887	Adapter, 90° .....	3
	1-603921	O-Ring .....	1
34	3256-22	Washer, 1/4 SAE.....	2
35	32128-33	Nut, Whizlock 1/4-20 .....	2
36	32128-43	Nut, Whizlock 3/8-16 .....	4
37	32128-49	Nut, Whizlock 1/2-13 .....	8
38	103-5477	Hose, Hydraulic .....	1
39	103-8617	Hose, Hydraulic .....	1
40	109-1260	Hose, Hydraulic .....	1
41	109-1261	Hose, Hydraulic .....	1
42	109-1262	Hose, Hydraulic .....	1
43	109-1263	Hose, Hydraulic .....	1
44	109-1264	Hose, Hydraulic .....	1
45	3290-357	Nut, Whizlock 3/8-16 .....	2

Exmark black touch up spray paint – gloss black.

▲ Use Prolock, Nut Type (P/N 1-840022, .5ml tube) on setscrews, items #6 & #7.

⊕ Use only for operation below 32°F (0°C).

● Wheel Motor Service Kits		
Part No.	Description	Qty.
103-9762	Kit, Seal .....	1
103-9763	Handle, Actuating.....	1
103-9764	Clip, Retaining.....	1
103-9765	Nut, Hex Toplock 1-20UNEF-2B .....	1
103-4242	Asm, Wheel Hub W/Studs .....	1
103-7447	Stud, Wheel 1/2-20 x 1/2.....	4

■ Hydro Pump Service Kits		
Part No.	Description	Qty.
103-7441	Bearing, Input Shaft.....	1
103-7443	Kit, Cylinder Block 12CC.....	1
94-6922	Bearing, Thrust.....	1
105-6184	Kit, Overhaul Seal.....	1



# HYDRAULIC GROUP

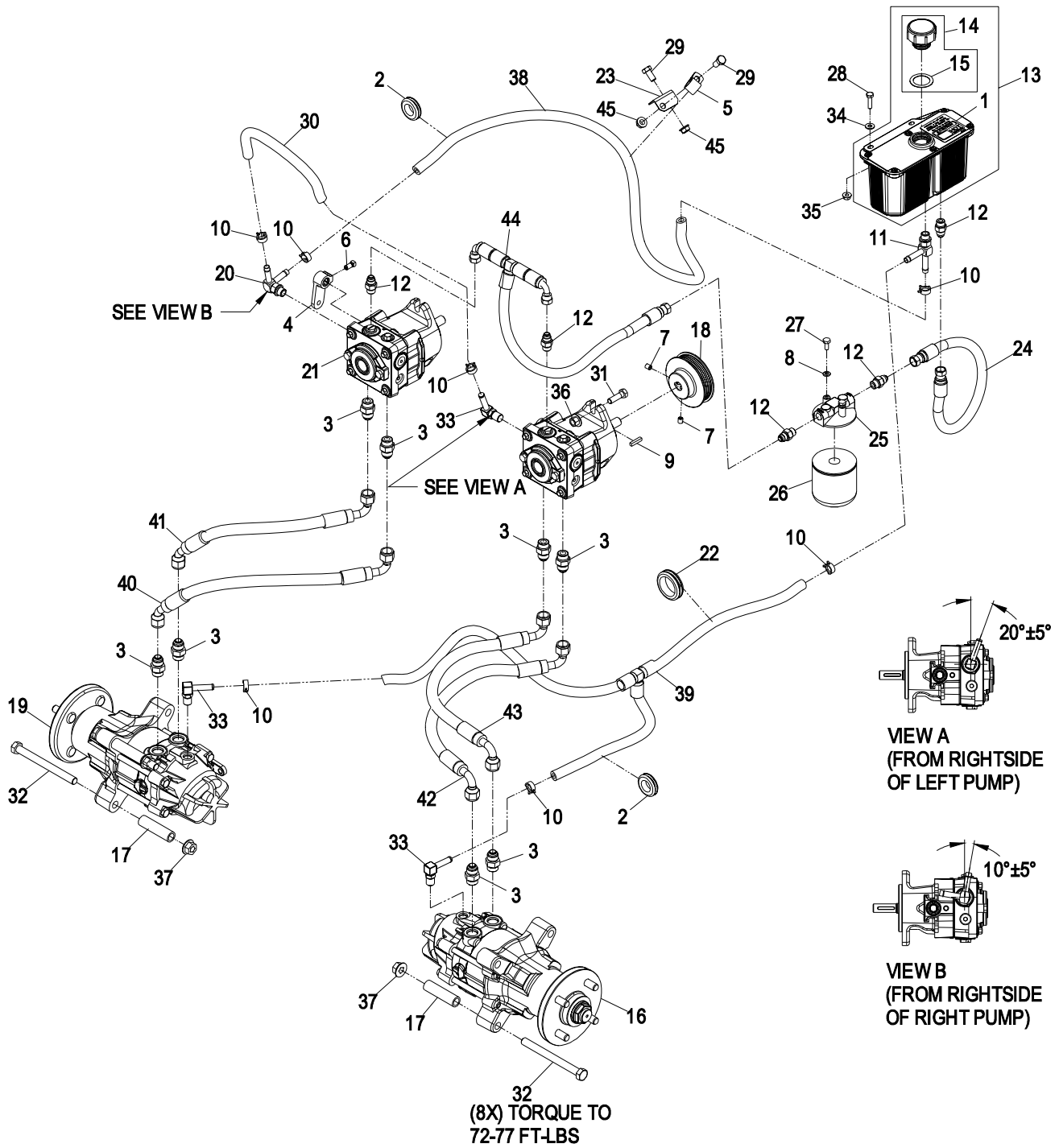

## HOPPER GROUP

Item	Part No.	Description	Qty.
1	1-543963	Bumper, Rubber.....	2
2	1-633068	Spacer .....	2
3	103-5045-03	Brace, Side .....	2
4♦	109-4086	Asm, Hopper Frame.....	1
5	103-5426	Stud, Ball 13mm .....	2
6	103-5736-03	Channel, Screen (RH).....	1
7	103-5746	Shock, Gas Tension.....	2
8	103-5749-03	Panel, Hinge (LH) .....	1
9	103-5751-03	Panel, Hinge (RH).....	1
10	103-5752	Stud, Ball 10mm .....	4
11	103-5772-03	Brace, Top .....	1
12	103-5774-03	Channel, Screen (LH) .....	1
13*	103-9457	Asm, Hopper.....	1
14	103-6022-03	Channel, Hopper Frame.....	1
15	103-6025	Shield, Trailing .....	1
16	103-7035-03	Channel, Screen Front.....	1
17	109-4019	Guard, Damper .....	2
18	103-7824	Insulation, Foam Pad Rear .....	1
19	103-7825	Insulation, Foam Pad Front.....	1
20	103-8324	Clip, Retainer-10mm.....	4

Item	Part No.	Description	Qty.
21	103-8325	Clip, Retainer-13mm.....	2
22	321-2	Screw, HH 1/4-20 x 1/2.....	4
23	323-6	Screw, HH 3/8-16 x 1.....	2
24	3229-2	Bolt, Carriage 1/4-20 x 1.....	4
25	3229-4	Bolt, Carriage 1/4-50 x 1 1/2.....	6
26	107069	Nut, Retainer .....	4
27	3256-24	Washer, 3/8 SAE.....	6
28	3256-3	Washer, 5/16 Std.....	4
29	3296-39	Nut, Nyloc 3/8-16.....	6
30	3296-42	Nut, Nyloc 1/4-20.....	29
31	32105-32	Screw, Truss HD 1/4-20 x 1.....	30
32	32128-20	Nut, Whizlock 5/16-18 .....	4
33	32128-33	Nut, Whizlock 1/4-20 .....	39
34	1-513762	Clip, Loom 1/2 .....	1
35	33005-00	Nut, Hex M10-1.5 Flg.....	2
36	614672	Screw, Shoulder 3/8-16 x 1.295.....	2
37	103-5425	Shock, Gas Compression .....	1
38	109-0715	Kit, Damper W/Clips .....	2
39	109-0716	Kit, Damper W/Clips .....	1

\* Reference page 20 for remainder of items included in hopper assembly

♦ Includes items: 1, 18, 19, 32 and frame weldment.

# HOPPER GROUP

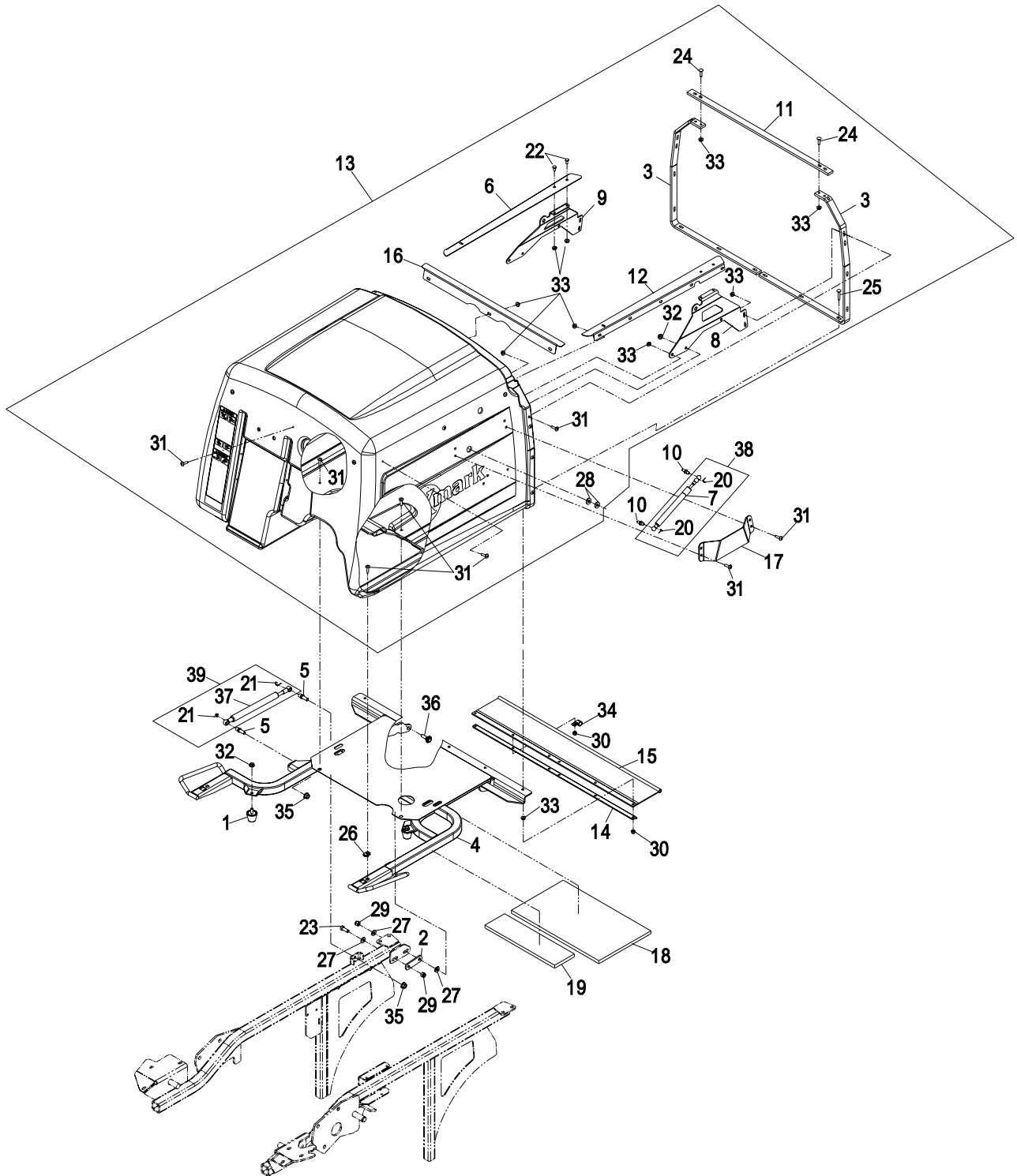

## HOPPER GROUP (cont.)

Item	Part No.	Description	Qty.
1	1-303435	Washer, Spring Disk 1/4 .....	3
2	109-3854	Kit, Fill Sensor Wire .....	1
3	1-513762	Clip, Loom 1/2.....	4
4	1-543296	Grommet.....	1
5	1-303335	Tie, Plastic .....	1
6	109-3955	Door, 9.5 Bushel Hopper.....	1
7	103-5745-03	Panel, Hopper Screen.....	1
8	109-4253	Asm, Door Pivot W/Decal (LH).....	1
9	109-4254	Wld, Door Pivot W/Decal (RH).....	1
10	103-6024	Decal, Exmark Logo.....	1
11	109-3648	Wld, Switch Mount .....	1
12	103-6067-03	Bracket, Motor (LH).....	1
13	103-6068-03	Bracket, Motor (RH) .....	1
14	103-7048-03	Panel, Screen Extend .....	1
15	109-4153-03	Wld, Door Support .....	1
16	103-7085-03	Plate, Switch.....	1
17	103-7098-03	Handle, Screen (LH) .....	1
18	103-7099-03	Handle, Screen (RH).....	1
19	109-3650-03	Wld, Diffuser .....	1
20	103-9466	Asm, Fill Sensor.....	1
21	109-0717	Asm, Hopper Screen.....	1
22	321-4	Screw, HH 1/4-20 x 3/4.....	5
23	103-8203-03	Guide, Screen.....	2
24	1-613235	Washer .....	2

Item	Part No.	Description	Qty.
25	103-8444	Decal, Pinch Point .....	2
26	103-8680	Deflector, Discharge Chute.....	1
27	103-8789	Flag, Fill Sensor.....	2
28	109-3853	Motor .....	1
29	103-9456	Asm, Door Hopper.....	1
30	321-2	Screw, HH 1/4-20 x 1/2.....	19
31	322-4	Screw, HH 5/16-18 x 7/8.....	4
32	329-4	Screw, HH 1/4-28 x 3/4.....	3
33	103-9457	Asm, Hopper.....	1
34	3230-23	Bolt, Carriage 5/16-18 x 3/4.....	6
35	3250-48	Screw, PPH #10-24 x 1 3/4.....	2
36	3256-2	Washer, 1/4 Std.....	17
37	9107622	Screw, PPH #6-32 x 5/8.....	2
38	3256-23	Washer, 5/16 SAE .....	4
39	32122-30	Screw, Truss HD #10-24 X 1/2 .....	2
40	109-1063	Screw, Wing 1/4-20 x 3/4.....	3
41	3296-2	Nut, Nyloc #10-24 .....	4
42	3296-42	Nut, Nyloc 1/4-20 .....	5
43	3296-9	Nut, Nyloc #6-32 Thin .....	2
44	32105-32	Screw, Truss HD 1/4-20 x 1 .....	6
45	107069	Nut, Retainer-Panel 1/4-20 .....	5
46	32128-20	Nut, Whizlock 5/16-18.....	8
47	32128-33	Nut, Whizlock 1/4-20 .....	27
48	32122-42	Screw, Truss HD 1/4-20 x 1/2.....	4

Reference page 18 for remainder of items included in hopper assembly.

# HOPPER GROUP (cont.)

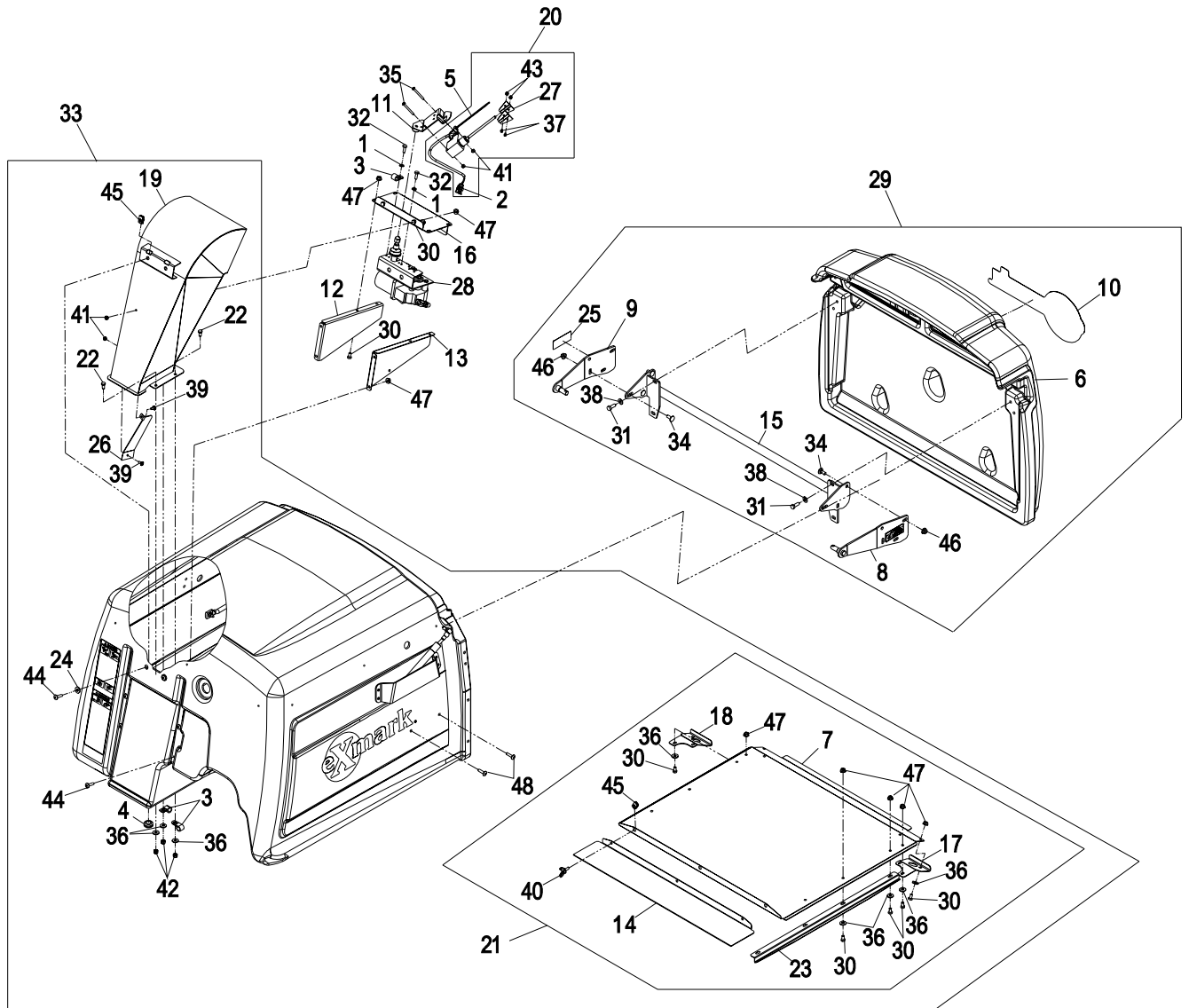

## ELECTRICAL GROUP

Item	Part No.	Description	Qty.
1	1-513051	Switch, N.O.....	1
2	1-513152	Switch, N.C.....	1
3	1-513180	Plate, Switch.....	1
4	1-513374	Meter, Hour.....	1
5	1-513747	Decal, Battery.....	1
6	1-522424-03	Wld, Mount Seat Spring.....	1
7	1-523415	Spring.....	1
8	109-2407	Insulator, Battery.....	1
9	1-543393	Insulator, Solenoid.....	1
10	1-543792	Wingnut, Nyloc 1/4-20.....	2
11	1-633111	Switch, N.C.....	2
12	1-633181	Plate, Tapped.....	4
13	1-643312	Clip, Loom 5/8.....	3
14+	109-2923	Asm, Positive Battery Cable.....	1
15	1-643267	Indicator, Red Led.....	1
16	1-643275	Relay, 12VDC 40 Amp.....	3
17	32128-33	Nut, Whizlock 1/4-20.....	7
18	103-0498	Nut, Ignition.....	1
19	1-807513	Bolt, Carriage #10-24 x 1/2.....	2
20	100-6186	Module, Seat Delay.....	1
21	103-0205	Alarm, Dual Tone 12VDC.....	2

Item	Part No.	Description	Qty.
22	109-4736	Asm, Switch W/Nut.....	1
23	103-2106	Key, Exmark Logo.....	1
	1-603511	Key, Ignition.....	1
24	103-1312	Bolt, Hold Down.....	2
25	1-816003	Fuse, 30 Amp.....	1
26	103-9470	Asm, Battery Hold Down W/Decal.....	1
27	1-816001	Fuse, 20 Amp.....	2
28	103-8354	Cable, Battery (+).....	1
29	103-8355	Cable, Ground (-).....	1
30+	109-4270	Harness, Wiring.....	1
31+	103-8800	Harness, Hopper Wire.....	1
32	321-4	Screw, HH 1/4-20 x 3/4.....	7
33	103-8528	Asm, Hopper Switch Actuator.....	1
34	1-303287	Tie, Cable 5 1/2 (Small).....	1
35	322-50	Screw, HH 5/16-18 x 7 1/2.....	1
36	3217-6	Nut, Hex 5/16-18.....	1
37	3256-2	Washer, 1/4 Std.....	5
38	3290-134	Screw, HH Machine 10-24 x 5/8.....	2
39	3290-500	Screw, PPH #10-24 x 5/8.....	8
40	3296-2	Nut, Nyloc #10-24.....	4
41	3296-29	Nut, Nyloc 5/16-18.....	1

- ◆ Use dielectric grease on all wiring harness connectors.
- + Assembly includes items #8, #9, and #28.

# ELECTRICAL GROUP

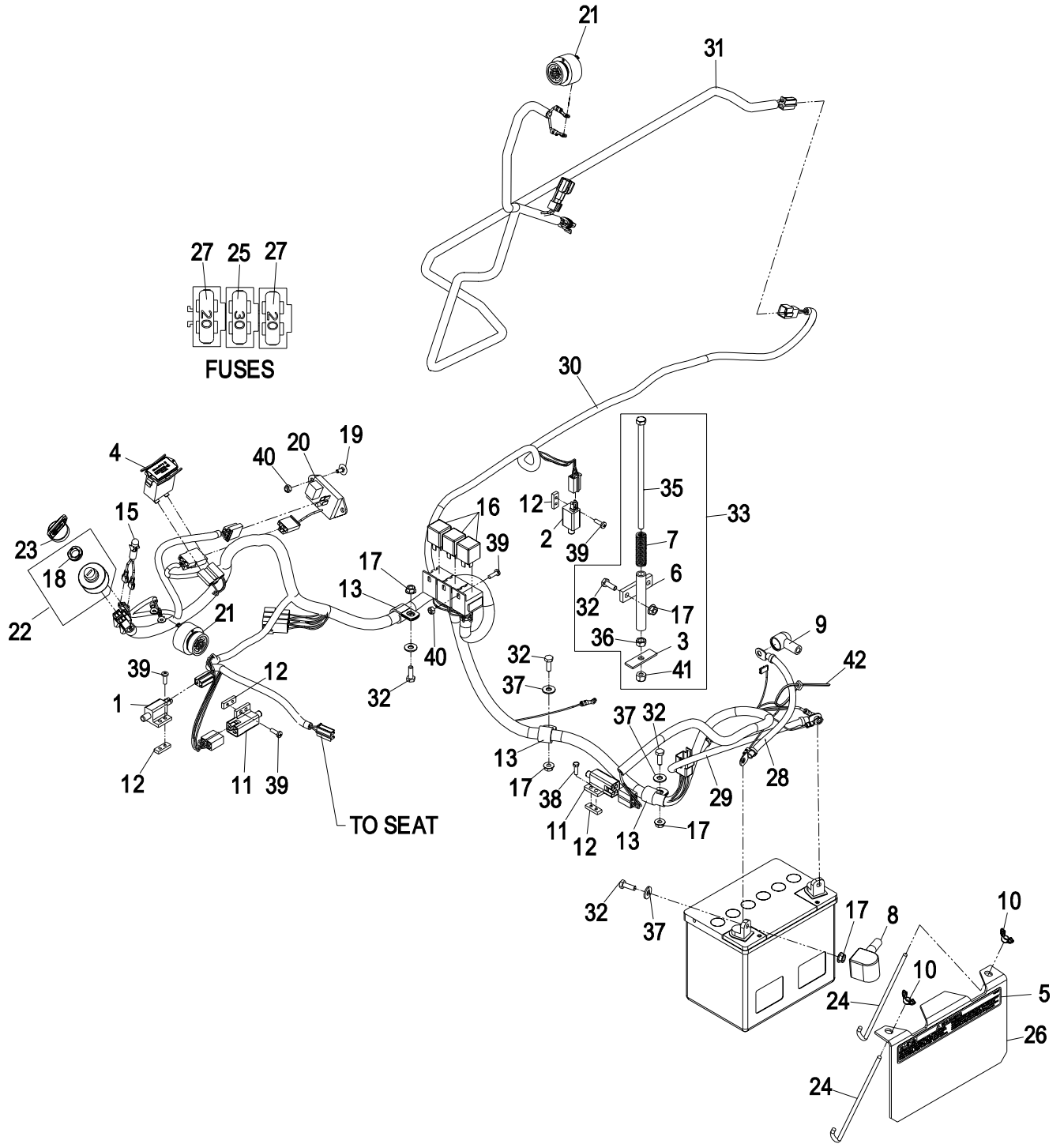

# ELECTRICAL DIAGRAM

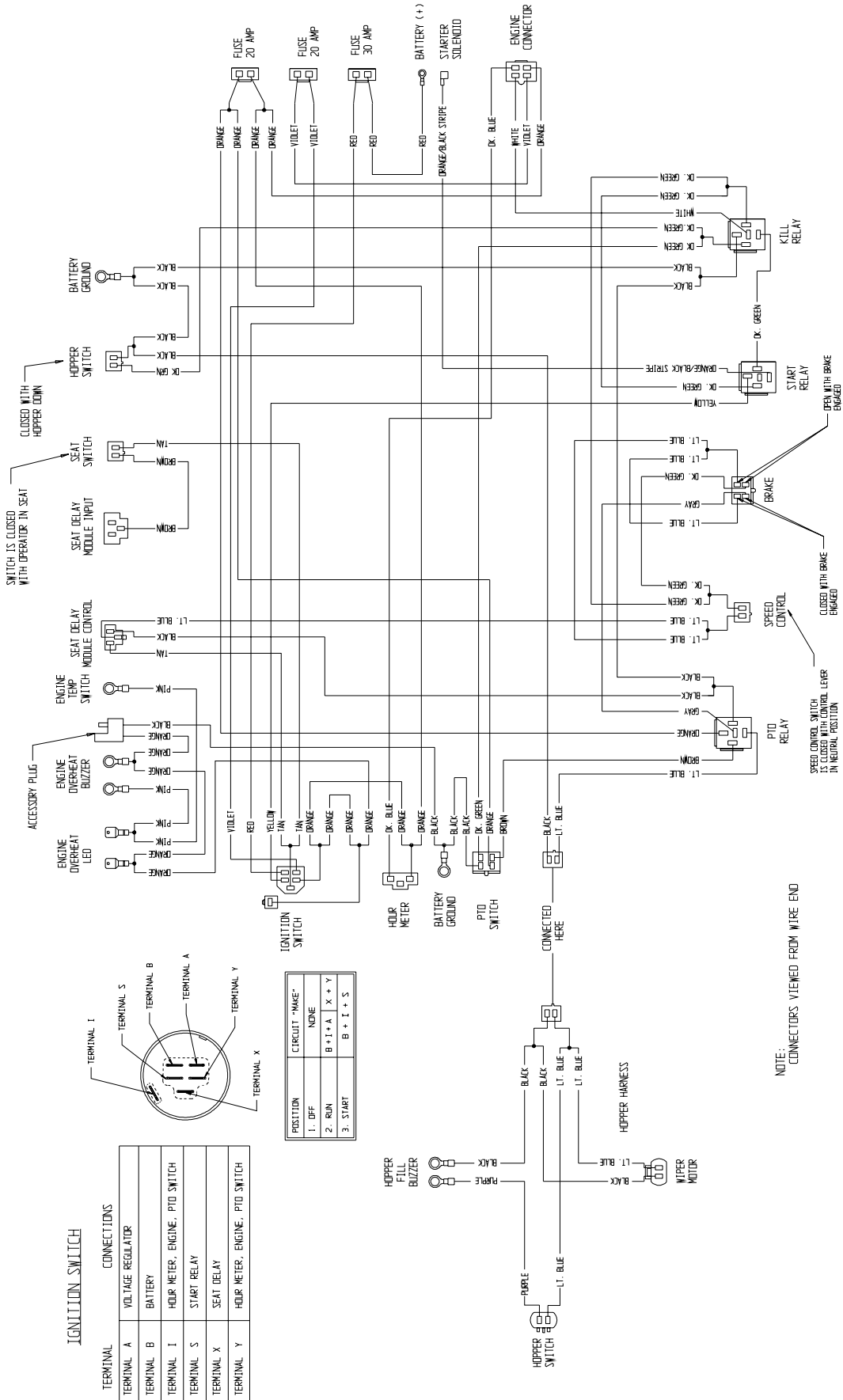

## IGNITION SWITCH

TERMINAL	CONNECTIONS
TERMINAL A	VOLTAGE REGULATOR
TERMINAL B	BATTERY
TERMINAL I	HOUR METER, ENGINE, PTO SWITCH
TERMINAL S	START RELAY
TERMINAL X	SEAT DELAY
TERMINAL Y	HOUR METER, ENGINE, PTO SWITCH

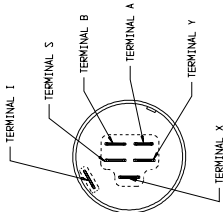

POSITION	CIRCUIT "MAKE"
1. OFF	NONE
2. RUN	B + I + A X + Y
3. START	B + I + S

NOTE: CONNECTORS VIEWED FROM WIRE END



# ELECTRICAL LOGIC SCHEMATIC

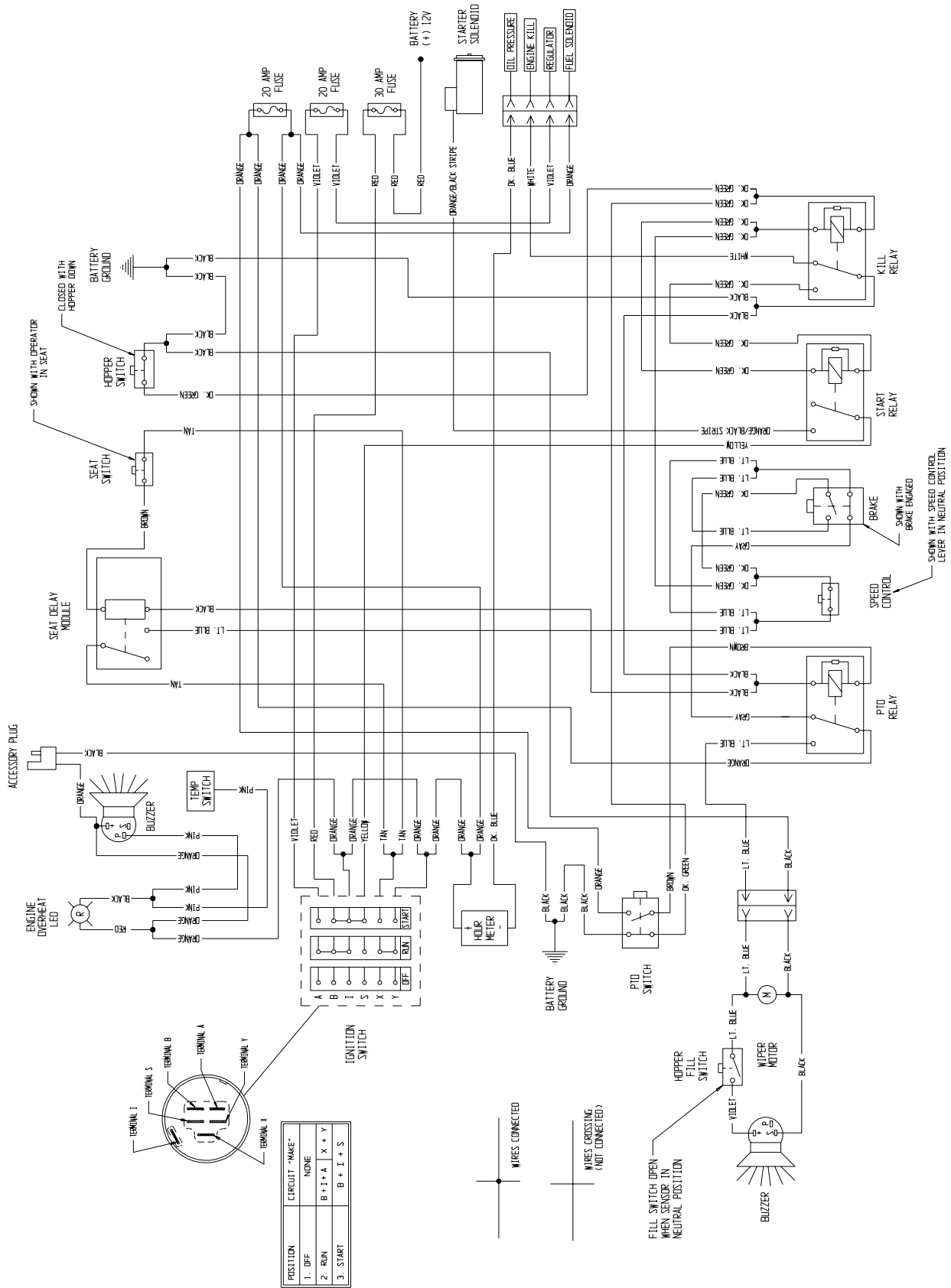

## DECALS GROUP



Item	Part No.	Description	Qty.
1	103-8451	Decal, Ignition/Speed Control .....	1
2	109-7318	Decal, Danger .....	2
3	103-9274	Decal, Belt Routing .....	1
4	98-5954	Decal, Missing Cover .....	2
5	103-8611	Decal, Relay .....	1
6	103-9034	Decal, Clutch Adjustment .....	1
7	1-523552	Decal, Hydraulic Tank .....	1
8	98-4361	Decal, Warning .....	2
9	1-513747	Decal, Battery .....	1

Item	Part No.	Description	Qty.
10	65-2690	Decal, Hot Surface .....	2
11	103-8425	Decal, Driveline .....	1
12	103-8444	Decal, Pinch Point .....	2
13	103-8495	Decal, Pinch Point .....	2
14	109-4273	Decal, Wheel Motor Release .....	1
15	103-6024	Decal, Exmark Logo .....	1
16	103-9032	Decal, Service Aid Navigator .....	1
17	109-4638	Decal, Instrument Panel .....	1
	103-9502	Kit, Decal	



## **SEE EXMARK'S COMPLETE LINE OF ACCESSORIES**

### **RIDING ACCESSORIES**

CUSTOM RIDE SEAT SUSPENSION SYSTEM  
DECK LIFT ASSIST KIT  
HITCH KIT  
LIGHT KIT  
MICRO-MULCH SYSTEM  
ROLL OVER PROTECTION SYSTEM (ROPS)  
SNOW BLADE  
SUN SHADE  
TRASH CONTAINER  
TURF STRIPER  
ULTRA VAC COLLECTION SYSTEM  
ULTRA VAC QUICK DISPOSAL SYSTEM

### **WALK BEHIND ACCESSORIES**

GRASS CATCHER  
MICRO-MULCH SYSTEM  
STEERABLE SULKY  
SULKY HITCH KIT  
TURF STRIPER  
STANDON

Check us out on the Web:  
**[www.exmark.com](http://www.exmark.com)**

© 2005-2007 EXMARK MFG. CO. INC.  
INDUSTRIAL PARK BOX 808  
BEATRICE, NE 68310

PART NO. 109-7321 Rev. A  
(402) 223-6300  
FAX (402) 223-5489

ALL RIGHTS RESERVED

PRINTED IN U.S.A.

