

eXmark®



TURF TRACER®

**For Serial Nos.
790,000 & Higher**
Part No. 4500-459 Rev. A

Parts Manual

EXMARK PARTS PLUS

PARTS

OVERNIGHT

OR *FREE**

If your Exmark dealer does not have the Exmark part in stock, Exmark will get the parts to the dealer the next business day or the part will be FREE Guaranteed!! (Some restrictions apply. See your participating Exmark Dealer for details.)



**READ OPERATOR'S MANUAL BEFORE
OPERATING OR SERVICING EXMARK EQUIPMENT.**

TABLE OF CONTENTS

<u>Description</u>	<u>Page</u>
Decals	10
ECS Upper Handles & Controls	3-4
Electrical Diagram.....	11
Electrical Group	9
Electrical Logic Schematic	12
Engine Deck Group	5-7
Hydraulics Group	8

ECS UPPER HANDLES AND CONTROLS

Item	Part No.	Description	Qty.
1	322-9	Screw, 5/16-18 x 1 3/4	2
2	1-806003	Hairpin Cotter.....	2
3+	103-1566-03	Lever Weldmt OPC LH.....	1
4◆	1-803322	Setscrew, 5/16-24 x 5/16.....	2
5	1-303365	Bushing, Nylon.....	2
6	103-0769-03	Lever Axle Weldmt, OPC	1
7	1-303363	Spring, OPC Extension	1
8+	103-1567-03	Lever Weldmt, OPC RH.....	1
9	1-807513	Bolt, #10-24 x 1/2 Carriage	2
10	110-5720	Choke Control Push/Pull	1
11	109-3958	Cable, Throttle	1
12	3296-2	Nut, #10-24 Nyloc.....	2
13	103-1537-03	Handle Weldmt, Upper ECS.....	1
14	103-0815	Grip, Handle Bar	2
15	1-413152	Bearing	4
16	103-2514	Lever, Drive LH.....	1
17	103-0027	Bushing, Drive Lever.....	2
18	321-14	Screw, 1/4-20 x 2 3/4	2
19	32128-33	Nut, 1/4-20 Whizlock.....	12
20	103-0464	Pin, 1/8 x 1/2 Spring.....	2
21	3256-22	Washer 1/4 SAE Flat.....	10
22	1-303435	Washer, 1/4 Disc Spring.....	6
23	103-1371	Thumb Latch Asm RH(Shown).....	1
	103-1372	Thumb Latch Asm LH (Not Shown).....	1
24◆	103-0235	Screw, 1/4-20 x 1-1/8 W/Nylon.....	2

Item	Part No.	Description	Qty.
25	103-2513	Lever, Drive RH	1
26	3290-357	Nut, 3/8-16 Whizlock.....	4
27	98-5975	Washer, 3/8 Disc Spring.....	4
28	323-6	Screw, 3/8-16 x 1.....	4
29	3220-3	Nut, Jam 3/8-24	4
30	322-10	Screw, 5/16-18 x 2.....	2
31	1-603716	Washer, Friction Disc.....	1
32	1-323244	Washer, Friction.....	2
33	109-4508	Console 109-4506-03 W/ Decals	1
34	103-0773	Speed Shift Weldmt	1
35	103-0423	Knob .38-16 Nyloc	1
36	3296-29	Nut, 5/16-18 Nyloc.....	4
37	1-323245	Spring, Compression	2
38	3256-23	Washer 5/16 SAE Flat	10
39	321-3	Screw, 1/4-20 x 5/8.....	10
40	1-413225	Rod, Speed Control	1
41	3220-2	Nut, 5/16-24 Jam	1
42	1-303105	Yoke	1
43	1-808280	Clevis Pin 5/16 x 1	1
44	103-2513	Asm, Drive Lever RH	1
	103-2514	Asm, Drive Lever LH.....	1
45	103-2463	Joint, .31 Ball End.....	2
46	103-0503	Bracket, Shifter Slide	1
47	103-0489-03	Bracket, OPC Axle.....	1
48	3219-3	Nut, Reg Hex 3/8-24	2

Exmark black touch up spray paint – Gloss black.

◆ Use Pro-Lock nut type, (P/N. 1-840022, .5cc tube) on setscrew threads and thumb latch screw threads.

+ Use Pro-Lock retaining type, (P/N. 1-840023, .5cc tube) on inside of bore of OPC hub.

ECS UPPER HANDLES AND CONTROLS

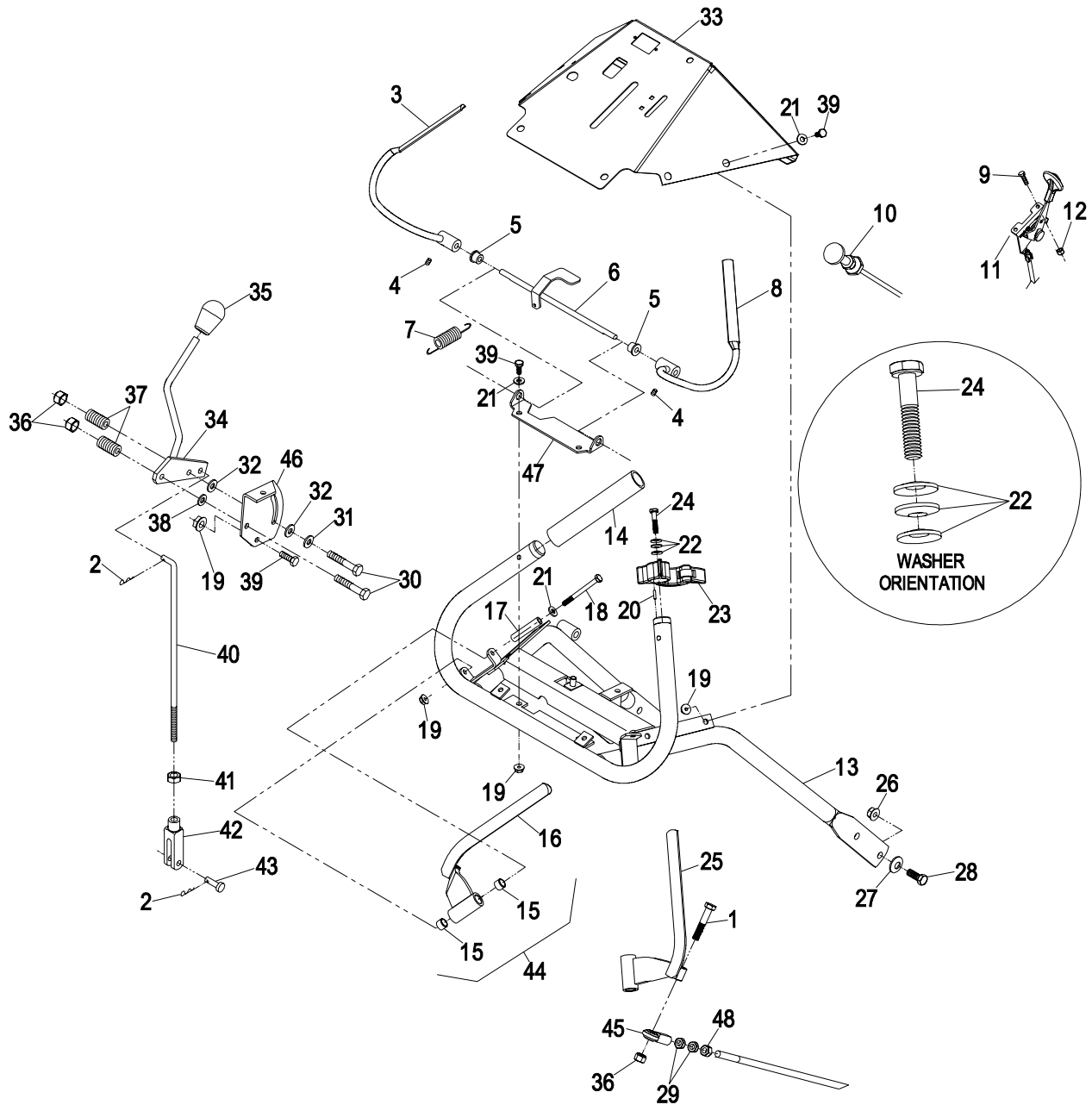

ENGINE DECK GROUP

Item	Part No.	Description	Qty.
1	109-6408	Eng Deck 116-0563-01 W/ Decals	1
2	109-4490	Asm, Hose Oil Drain W/Plug (KAW)	1
	109-2987	Asm, Hose Oil Drain W/Plug (KOH)	1
3	109-1012	Plug	1
4	1-303335	Tie, Plastic	1
5	1-602997	Hub, 4 Bolt	2
	1-633926	Stud	8
6	103-1715	Tire And Wheel Assy.....	2
	103-2237	Tire Only 18 x 8.50.....	2
	103-2238	Wheel Only	2
7	242-50	Nut, Wheel	8
8	1-807019	Key, Woodruff 1" x 1/4"	2
9	1-806800	Pin, Cotter 9/64 x 1 1/2	2
10	32136-5	Nut, 3/4-16-2B Slotted Hex	2
11	1-613089	Anchor, Spring	2
12	1-413510	Clip, Loom 2.06 Dia.....	3
13	1-807259	Key, 1/4 x 1/4 x 1	1
14	103-2240	Belt, Deck Drive(52").....	1
	1-603306	Belt, Deck Drive(60").....	1
15	103-0662	Clutch W/Plastic Tie	1
16	1-633543-03	Strap, Clutch	1
17	1-323195-03	Standoff, Clutch	1
18	1-303287	Plastic Tie, Small	1
19	103-1167	Joint, .38x.38FE LH Ball End.....	2
20●	1-653035	Sheave, 4 1/4 O.D	1
21	1-413010	Sheave, Pump	2
22	1-807272	Key, 5mm Sq x 25mm.....	2
23▲	1-803050	Setscrew, 5/16-18 x 3/4.....	4
24	109-4077	Pulley, Idler	1
25	1-603496	Bushing, Idler.....	3
26	109-2578	Kit, Idler Arm W/Bearings	1
27	302-40	Zerk, 90° 1/4-28	1
28	1-603414	Spring, Extension.....	1
29	103-3506	Seal, Single Lip	1
30	302-19	Zerk, Grease 1/4-20	2
31	1-633102	Bearing, Flanged.....	2
32	1-613206	Rod, Control Arm	2
33	1-323245	Spring	1
34	1-603676	Swivel	2
35	1-413151	Knob, Tracking.....	1
36	103-4673-01	Support, Tank/Handle	1
37	103-1561-01	Arm, Control LH	1
38	103-1562-01	Arm, Control RH(Not Shown).....	1
39	109-2584	Belt, Hyd Trans Drive ("A" Belt).....	1
40	1-603693	Spring, Extension.....	2
41	103-2234-01	Crank Weldment	1
42	1-603737	Bolt, Neutral Return.....	2
43	103-0265	Spring, Neutral Return	2
44	1-603735	Bushing, Flanged.....	2
45	1-303105	Yoke, Adjustable.....	2

Item	Part No.	Description	Qty.
46	322-3	Screw, 5/16-18 x 3/4	14
47	103-2421	Tube, Pump Link Spacer	2
48	3290-357	Nut, 3/8-16 Whizlock	6
49	32128-20	Nut, 5/16-18 Whizlock.....	28
50	322-38	Screw, 5/16-18 x 4 1/2.....	1
51	322-6	Screw, 5/16-18 x 1 1/4	1
52▲	3212-12	Screw, 7/16-20 x 3 (KAW).....	1
	3212-10	Screw, 7/16-20 x 2 1/2 (KOH).....	1
53	1-603610	Washer, Spring Disc	2
54	1-633545	Spacer, Clutch Anchor.....	2
55	1-613235	Washer	4
56	3296-29	Nut, Nyloc 5/16-18.....	6
57	322-7	Screw, 5/16-18 x 1 1/2.....	4
58	1-303334	Washer, 5/16 Disc Spring	4
59	1-800016	Bolt, Tap 5/16-18 x 1 1/4.....	2
60▲	1-800805	Screw, 3/8-16 x 3 1/2 Gr8	1
61	3253-5	Washer, Lock 3/8 Heavy.....	1
62	3256-4	Washer	3
63	323-9	Screw, HH 3/8-16 x 1 3/4.....	1
64	1-806003	Hairpin, Cotter	2
65	1-808280	Clevis Pin.....	2
66	3256-23	Washer, 5/16	11
67	1-403180	Screw, 5/16-18 x 1-3/8 Special	2
68	1-603903	Spacer	1
69	3219-2	Nut 5/16-24 Regular.....	7
70	3220-2	Nut, 5/16-24 Jam	2
71	3256-2	Washer, 1/4	2
72	323-8	Screw, 3/8-16 x 1 1/2.....	4
73	322-6	Screw, 5/16-18 x 1-1/4.....	2
74	1-805005	Washer, Lock 5/16 Heavy	4
75▲	1-809056	Screw, 3/8 x 3/8 Sckt Hd Shld.....	2
76	3256-24	Washer, 3/8 SAE Flat	3
77	323-6	Screw, HH 3/8-16 x 1	8
78	1-633630	Grommet	2
79	103-1576	Rod, Drive Lever.....	2
80▲	1-803022	Setscrew, 5/16-18 x 5/8	2
81	3272-5	Cotter Pin.....	2
82	1-303335	Plastic Tie (Large).....	1
83	103-2224	Shield, Drag	1
84	3256-3	Washer, Flat 5/16 Std	3
85	3220-16	Nut, Jam 3/8-24 LH.....	2
86	3218-2	Nut, Jam 5/16-18	2
87	103-5677	Spacer	1
88	106-7159	O-ring	2
89	103-3505	Seal, Double, Lip	1
90	32120-10	Ring, Retaining	2
91	103-3504	Bearing, Spherical	2
92	1-633068	Plate	1
93	98-5975	Washer, Spring Disc 3/8	8

Exmark black touch up spray paint – Gloss black.

Exmark red touch up paint (spray paint - P/N 1-850337 - .6 oz liquid bottle - P/N 103-9140).

● Install sheave with long end of hub up.

▲ Use Pro-Lock, nut type (P/N 1-840022, .5cc tube) on setscrew threads, shoulder bolt threads, clutch retaining bolt, and pump drive idler bolt.

ENGINE DECK GROUP

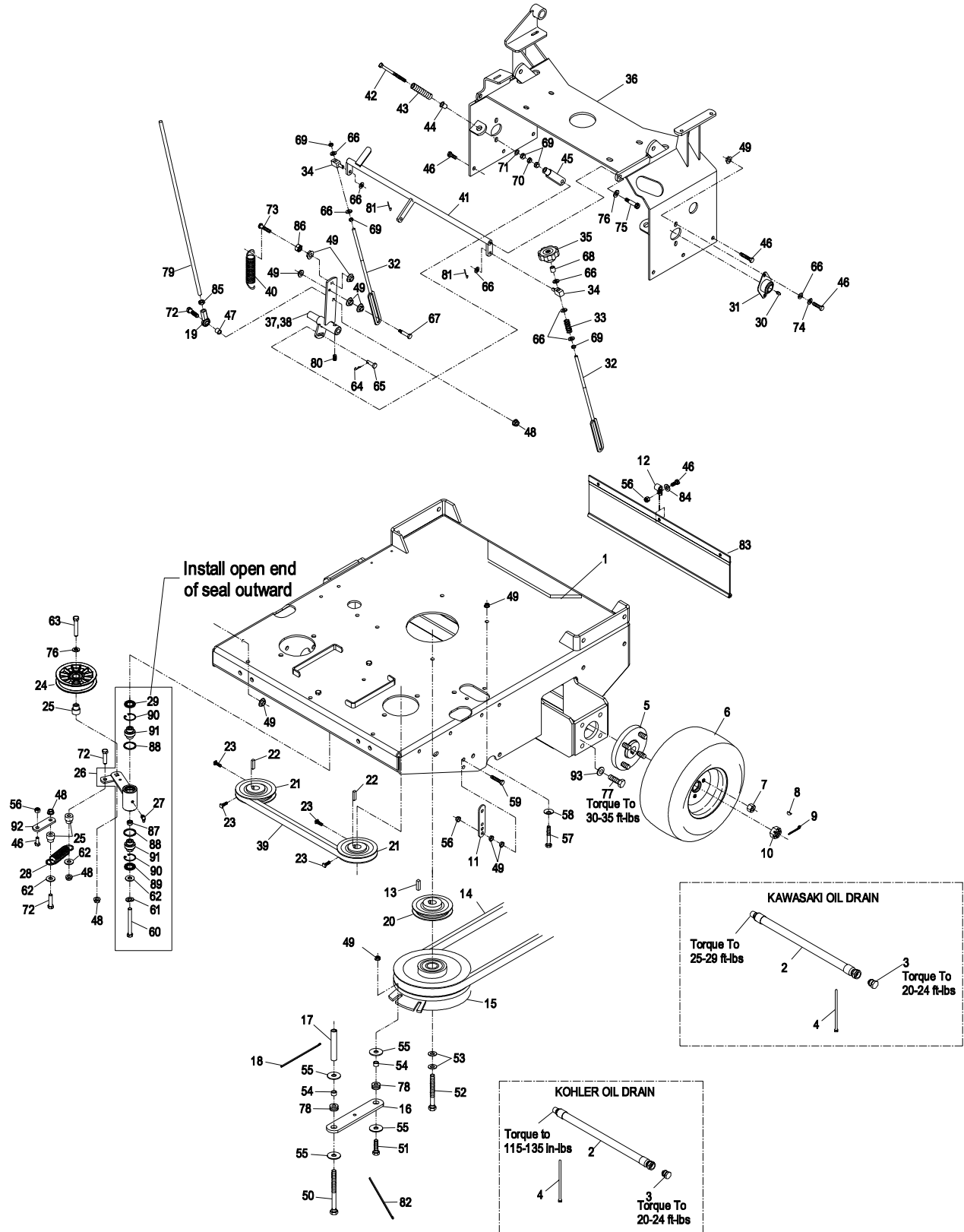

ENGINE DECK GROUP (cont.)

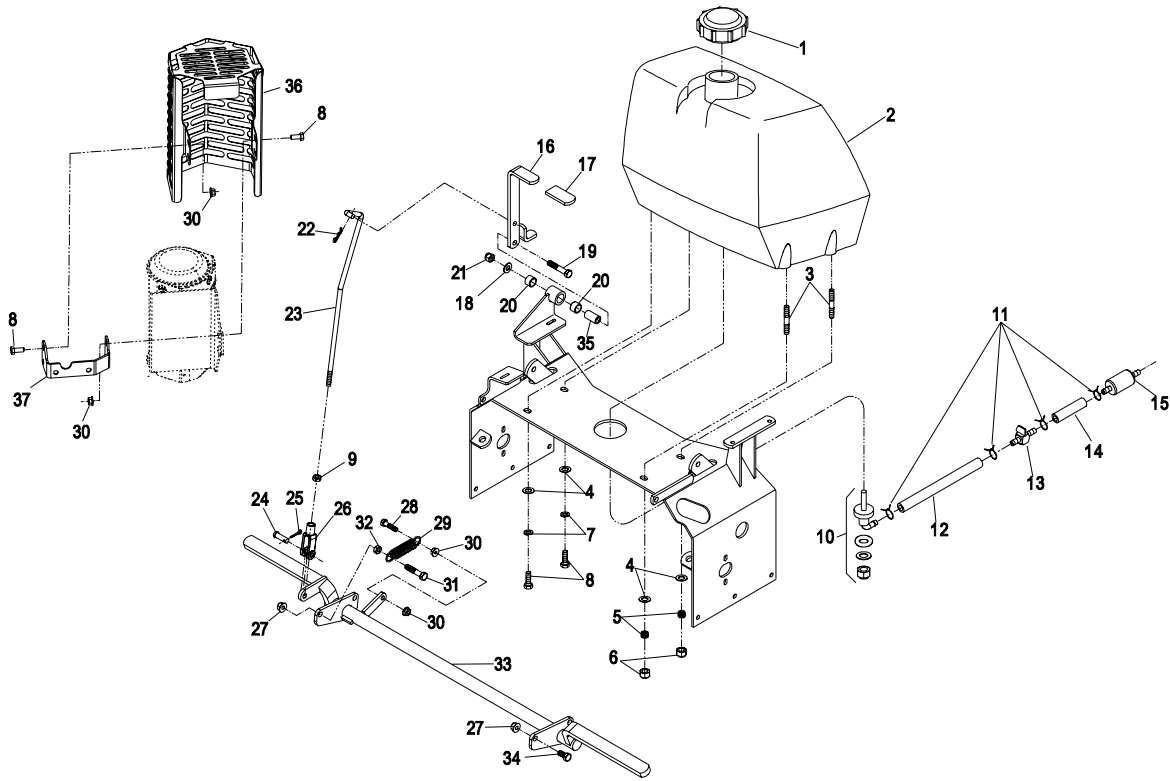

Item	Part No.	Description	Qty.
1	109-0346	Cap, Gas.....	1
2	103-2893	Tank, Fuel W/Fitting	1
3◆	1-633023	Stud, Fuel Tank.....	2
4	3256-23	Washer, Flat 5/16 Std	4
5	1-633349	Spring, Fuel Tank.....	2
6	3296-47	Nut, Nyloc 5/16-18	2
7	1-805005	Washer, 5/16 Lock	2
8	322-3	Screw, 5/16-18 x 3/4	6
9	3220-3	Nut, 3/8-24 Jam	1
10+	103-2605	Fitting, Fuel Bulkhd W/ Screen	1
11	1-303077	Clamp, Fuel Line.....	4
12	109-0303	Hose, Fuel 7.0 (KAW)	1
	109-0293	Hose, Fuel 8.5 (KOH).....	1
13	1-603770	Valve, Fuel.....	1
14	109-0293	Hose, Fuel 8.5 (KAW)	1
	109-0304	Hose, Fuel 2.5 (KOH).....	1
15	Kawasaki	Part No. 49019-7001 Fuel Filter	1
	Kohler	Part No. 2405010 Fuel Filter	1
16	109-4544	Lever, Park Brake (109-4543-03) W/Decal & Grip	1
17	1-303020	Grip, Lever	1

Item	Part No.	Description	Qty.
18	3256-24	Washer, 3/8 SAE Flat	1
19	323-10	Screw, 3/8-16 x 2.....	1
20	1-413347	Sleeve, Bushing.....	2
21	3296-39	Nut, 3/8-16 Nyloc.....	1
22	1-806003	Hairpin, Cotter	1
23	109-4078	Linkage, Park Brake.....	1
24	1-808285	Pin, Clevis 3/8 x 1 1/8	1
25	3272-10	Pin, Cotter 1/8 x 3/4	1
26	1-633131	Yoke, Brake Linkage.....	1
27	3290-357	Nut, 3/8-16 Whizlock.....	4
28	322-6	Screw, 5/16-18 x 1 1/4	1
29	1-323161	Spring.....	1
30	32128-20	Nut, 5/16-18 Whizlock.....	6
31	323-9	Screw, 3/8-16 x 1 3/4	1
32	3218-3	Nut, Jam 3/8-16.....	1
33	103-2205-03	Brake Weldmt.....	1
34	323-4	Screw, 3/8-16 x 3/4.....	3
35	1-413344	Bushing, Pivot.....	1
36	115-4155-03	Guard, Muffer.....	1
37	115-4156-03	Bracket, Muffer.....	1

Exmark black touch up spray paint – Gloss black.

✦ Use Pro-lock, nut type (P/N 1-840022, .5ml tube) on fuel fitting threads.

◆ Use Pro-lock, retaining type (P/N 1-840023, .5cc tube) on stud threads going into the tank.

Kohler Replacement Parts List

(Refer to Engine Owner's Manual)

Description	Kohler P/N
Air Filter Element Outer	2508301-S
Air Filter element Inner	2508304-S

Kawasaki Replacement Parts List

Description	Kawasaki P/N
Air Filter Element Kit	11010-7004
(Inner & Outer)	

HYDRAULICS GROUP

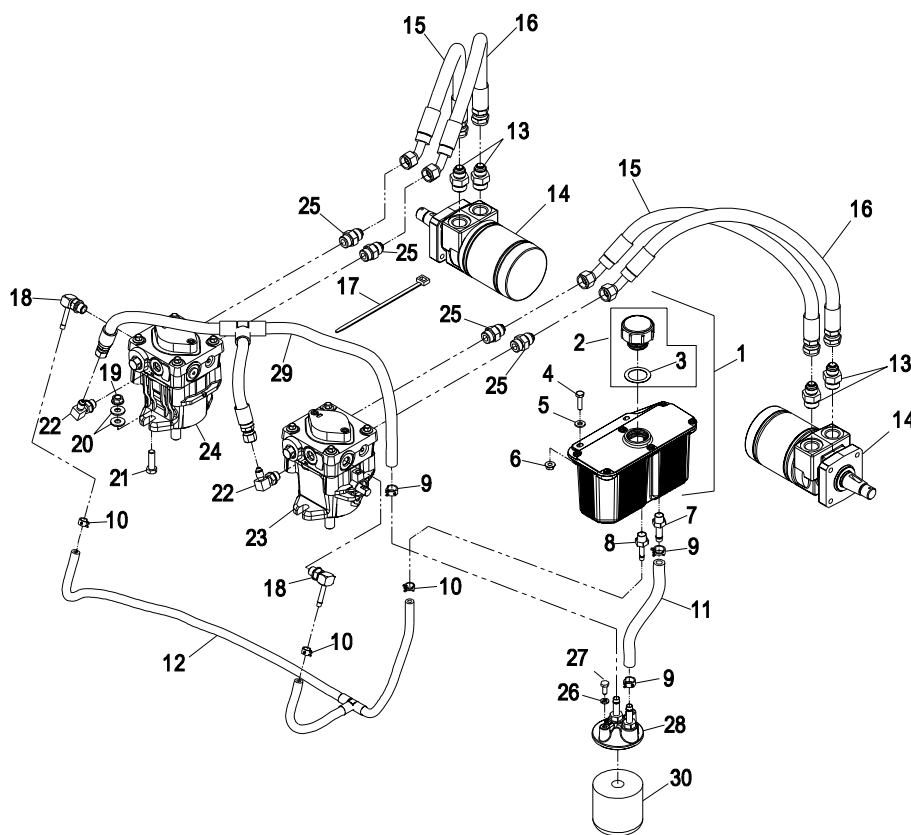

Item	Part No.	Description	Qty.
1	103-1947	Asm, Hydraulic Reservoir.....	1
2	103-7615	Asm, Cap W/Gasket.....	1
3	103-1949	Gasket, Reservoir Cap.....	1
4	321-6	Screw, 1/4-20 x 1.....	2
5	3256-22	Washer, 1/4 SAE Flat.....	2
6	32128-33	Nut, Whizlock 1/4-20.....	2
7	103-1912	Adapter, Straight.....	1
	1-603921	O-Ring.....	1
8	103-1801	Adapter, Straight.....	1
	1-603921	O-Ring.....	1
9	103-1988	Clamp, Hose (11/16).....	3
10	103-1716	Clamp, Hose (17/32).....	3
11	109-1010	Hose, Charge.....	1
12	103-4607	Asm, Case Drain Hose.....	1
13	1-603991	Fitting, Straight Connector.....	4
	1-603919	Boss O-Ring.....	1
	1-603992	Flare O-Ring.....	1
14	1-603718	Motor, Wheel.....	2
	1-000119	Kit, Seal.....	1
	1-000138	Kit, Bearing.....	1
15	103-4609	Hose, Hydro.....	2
16	103-4610	Hose, Hydro.....	2
17	1-303335	Tie, Cable (Large).....	1
18	103-1799	Elbow, 90°.....	2
	1-603921	O-Ring.....	1
19	3290-357	Nut, Whizlock 3/8-16.....	4

Item	Part No.	Description	Qty.
20	3256-3	Washer, 5/16 Std.....	8
21	323-7	Screw, 3/8-16 x 1-1/4.....	4
22	103-1802	Elbow, 90°.....	2
	1-603921	O-Ring.....	1
23	109-4987	Pump, Hydro RH.....	1
	103-2664	Kit, Input Shaft 10A.....	1
	94-6922	Kit, Thrust Bearing 10A.....	1
	103-2666	Kit, Cylinder Block 10A.....	1
	105-6184	Kit, Overhaul Seal.....	1
24	109-4988	Pump, Hydro LH.....	1
	103-2664	Kit, Input Shaft 10A.....	1
	94-6922	Kit, Thrust Bearing 10A.....	1
	103-2666	Kit, Cylinder Block 10A.....	1
	105-6184	Kit, Overhaul Seal.....	1
25	1-603990	Adapter, Straight Thread.....	4
	1-603920	Boss O-Ring.....	1
	1-603992	Flare O-Ring.....	1
26	1-805004	Washer, 1/4 Lock.....	2
27	321-3	Screw, 1/4-20 x 5/8.....	2
28	103-2889	Asm, Filter Head.....	1
	103-1912	Adapter, Straight.....	2
	1-603921	O-Ring.....	1
29	103-4608	Asm, Charge Hose.....	1
30	109-4180	Element, Oil Filter.....	1
▲	1-523541	Element, Oil Filter(Winter).....	1

Exmark black touch up spray paint – Gloss black.

▲ Use only for operation below 32°F (0°C).

ELECTRICAL GROUP

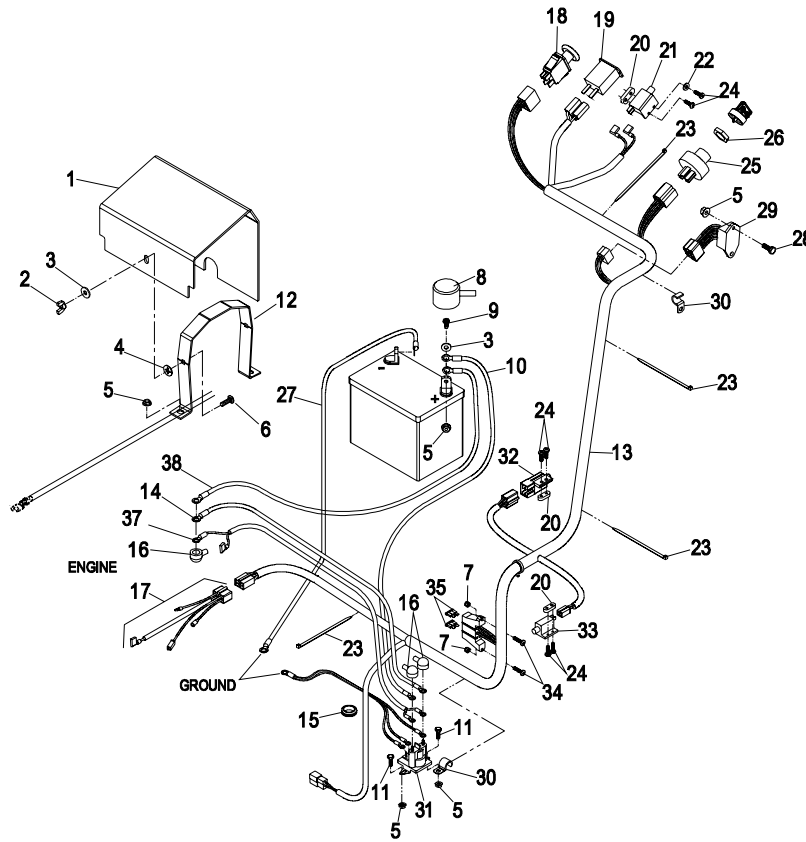

Item	Part No.	Description	Qty.
1	103-3424	Cover, Battery (1-603105) W/Decal	1
2	1-803038	Wingnut, 1/4-20	2
3	3256-2	Washer, 1/4 Flat	4
4	1-803037	Nut, Retaining 1/4-20.....	2
5	32128-33	Nut, Whizlock 1/4-20.....	7
6	1-807512	Bolt, Carriage 1/4-20 x 3/4	2
7	3296-2	Nut, Nyloc #10-24.....	2
8	109-2407	Insulator, Battery +	1
9	321-4	Screw, 1/4-20 x 3/4.....	2
10▲●	109-7653	Cable, Battery To Solenoid (+).....	1
11	321-2	Screw, 1/4-20 x 1/2.....	2
12	1-603814-03	Strap, Battery Holddown	1
13	109-2175	Harness, Wiring.....	1
14▲	109-7654	Cable, Solenoid To Starter (+).....	1
15	1-543286	Grommet	1
16	1-543393	Insulator, Solenoid.....	3
17▲	1-613262	Harness, Wiring.....	1
18	103-5221	Switch, PTO	1
19	1-513374	Meter, Engine Hour	1
20	1-633181	Plate, Tapped	3

Item	Part No.	Description	Qty.
21	1-513051	Switch, N.O.	1
22	3256-14	Washer, Flat #10	1
23	1-303335	Plastic Tie	4
24	3290-500	Screw, #10-24 x 5/8	6
25	1-543070	Switch, Ignition W/Keys	1
	1-603511	Key, Ignition	1
	103-2106	Key, Exmark Logo	1
26	103-0498	Nut, Ignition.....	1
27	1-543767	Cable, Ground.....	1
28	321-3	Screw, 1/4-20 x 5/8	1
29	1-613198	Module, Safety Interlock.....	1
30	103-1193	Clip, Loom Half.....	2
31	1-513075	Switch, 12V Solenoid	1
32	1-633111	Switch, N.O./N.C.	1
33	1-513152	Switch, N.C.	1
34	1-803075	Screw, #10-24 x 3/4	2
35	1-816001	Fuse, Blade 20 Amp.....	2
36	3296-2	Nut, Nyloc #10-24.....	2
37■	109-8395	Harness, Solenoid To Starter	1
38■	109-7630	Cable, Solenoid To Starter (+).....	1

Exmark black touch up spray paint – Gloss black.
Apply dielectric grease to all electrical connectors.

- Kohler units only.
- ▲ Kawasaki units only
- Includes items 8 & 16.

DECALS

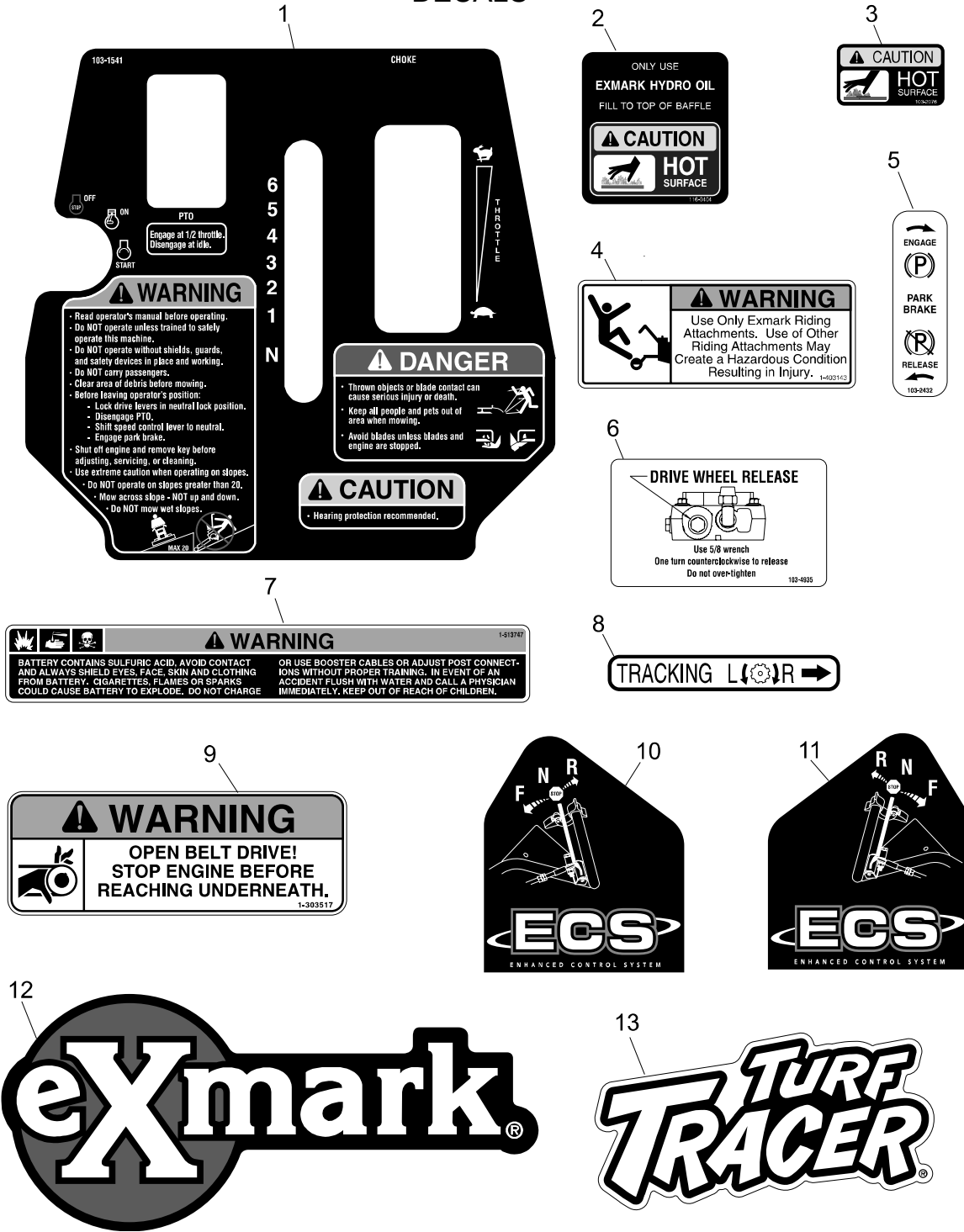

Item	Part No.	Description	Qty.
1	103-1541	Decal, Console ECS	1
2	116-0404	Decal, Hydraulic Tank	1
3	103-2076	Decal, Caution Hot Surface	1
4	1-403143	Decal, Sulky Warning	1
5	103-2432	Decal, Park Brake	1
6	103-4935	Decal, Drive Wheel Release	1
7	1-513747	Decal, Battery	1

Item	Part No.	Description	Qty.
8	1-413214	Decal, Tracking	1
9	1-303517	Decal, Belt Drive	1
10	103-2242	Decal, LH ECS Instruction	1
11	103-2243	Decal, RH ECS Instruction	1
12	103-2882	Decal, Exmark logo	1
13	103-3013	Decal, Turf Tracer	1
	103-5828	Kit, Decal Complete	

ELECTRICAL DIAGRAM

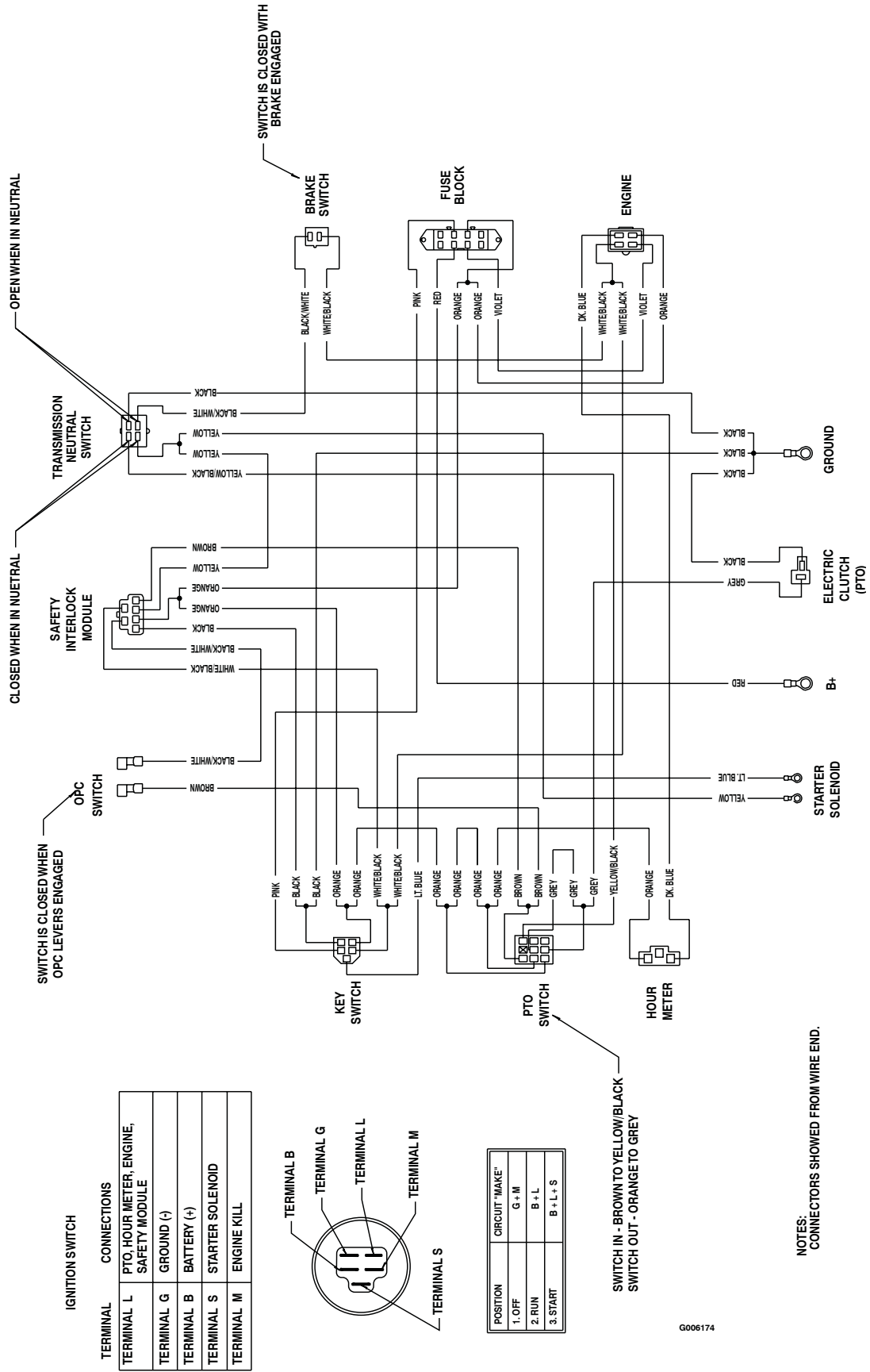

IGNITION SWITCH CONNECTIONS

TERMINAL	CONNECTIONS
TERMINAL L	PTO, HOUR METER, ENGINE, SAFETY MODULE
TERMINAL G	GROUND (-)
TERMINAL B	BATTERY (+)
TERMINAL S	STARTER SOLENOID
TERMINAL M	ENGINE KILL

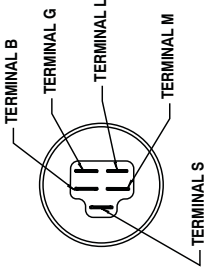

POSITION	CIRCUIT "MAKE"
1. OFF	G + M
2. RUN	B + L
3. START	B + L + S

SWITCH IN - BROWN TO YELLOW/BLACK
SWITCH OUT - ORANGE TO GREY

G006174

NOTES:
CONNECTORS SHOWN FROM WIRE END.

NEW EXMARK PREMIUM HYDRO OIL

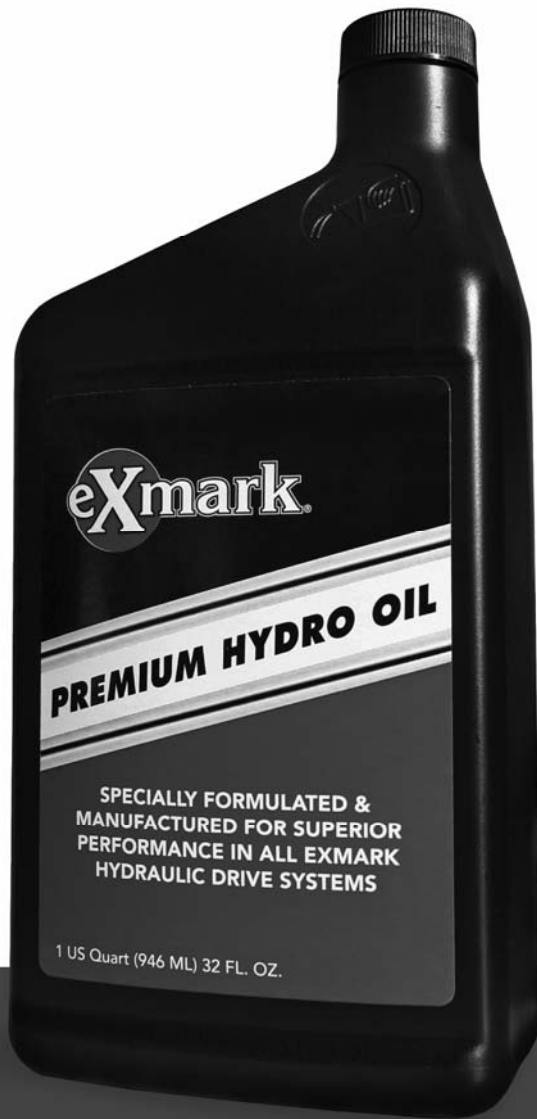

BENEFITS

- Designed & manufactured with superior anti-wear protection
- Superior thermal stability
- Consistent hydro performance
- Superior shear resistance under heavy loads
- Field tested & proven performance
- Twice the shear stability of competing oils
- Enhanced control performance
- Specially formulated for any Exmark hydraulic system

**NOW AVAILABLE
FOR PURCHASE**

Part No. 109-9828



SEE EXMARK'S COMPLETE LINE OF ACCESSORIES

MID-MOUNT RIDING ACCESSORIES

CUSTOM RIDE SEAT SUSPENSION SYSTEM	OPERATOR CONTROLLED DISCHARGE
FULL SUSPENSION SEAT	ROLL OVER PROTECTION SYSTEM (ROPS)
DECK LIFT ASSIST KIT	SUN SHADE
HITCH KIT	TRASH CONTAINER
LIGHT KIT	TURF STRIPER
12V POWER PORT	ULTRA VAC COLLECTION SYSTEM
MICRO-MULCH SYSTEM	ULTRA VAC QUICK DISPOSAL SYSTEM

OUT-FRONT RIDING ACCESSORIES

CUSTOM RIDE SEAT SUSPENSION SYSTEM	SNOW BLADE
DUAL-TAIL WHEEL	SNOWBLOWER
FLOOR PAN EXTENDER	SUN SHADE
HITCH KIT	TRASH CONTAINER
LIGHT KIT	ULTRA VAC COLLECTION SYSTEM
MICRO-MULCH SYSTEM	ULTRA VAC QUICK DISPOSAL SYSTEM
ROLL OVER PROTECTION SYSTEM (ROPS)	WEATHER CAB

WALK-BEHIND ACCESSORIES

GRASS CATCHER	TURF STRIPER
MICRO-MULCH SYSTEM	STANDON

Place Model No. and Serial No.
Label Here (Included in the Literature
Pack or Fill in Below)

Model No. _____

Serial No. _____

Date Purchased _____

Engine Model No. and Spec. No. _____

Engine Serial No. (E/No) _____

© 2009 Exmark Mfg. Co., Inc.
Industrial Park Box 808
Beatrice, NE 68310
All Rights Reserved

Part No. 4500-459 Rev. A
(402) 223-6300
Fax (402) 223-5489
Printed In USA.



www.exmark.com