

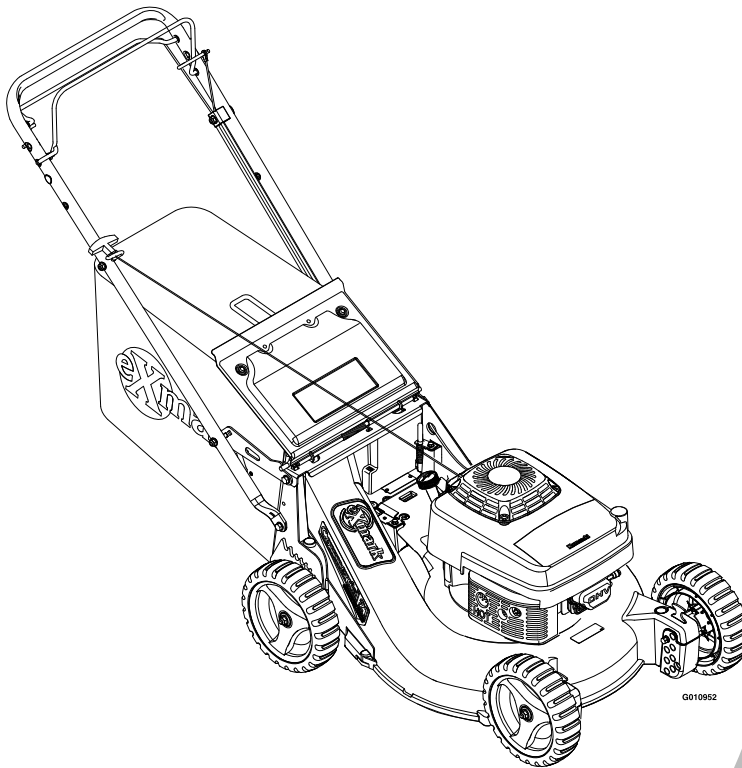

COMMERCIAL 21

Model No. ECXKABBC21—Serial No. 920000 and Up

Picture below may not reflect actual product.



Parts Manual

Part No. 4500-823 Rev. B

Ordering Replacement Parts

To order replacement parts, please supply the part number, the quantity, and the description of each part desired.

Understanding Reference Numbers

Each identified part in an illustration has a reference number. The reference number for a part also appears in the parts list, along with other information about the part.

This catalog uses two special reference number formats, one to indicate parts in a service assembly and another to indicate the quantity of a given part in an illustration.

Service Assembly Reference Numbers

Parts in service assemblies have reference numbers in the form a:b. The a represents the reference number of the entire service assembly and the b represents a sequential number unique to each part within the service assembly.

For example, a wheel assembly might be identified by reference number 6, the tire by 6:1, the valve by 6:2, and the wheel by 6:3. When you order the assembly identified by reference number 6, you receive all parts identified by reference numbers 6:1, 6:2, and 6:3. However, you may also order any part individually. Reference numbers of this type appear in illustration and in parts lists.

Reference Numbers Indicating Quantity

In an illustration, if a reference number indicates more than one part, the reference number has the form nX y. The n represents the quantity of the part, the X is the multiplication symbol, and the y represents the reference number.

For example, in an illustration, the reference number 2X 37 means that two of the parts identified by reference number 37 are indicated.

List of Abbreviations

AR: as required	HOC: height-of-cut	RRB: rear roller brush
ASM: assembly	HSBH: hex socket button head	SFH: slotted fillister head
BBC: blade brake control	HSFH: hex socket flat head	SHH: slotted hex head
BHTF: button head thread forming	HSH: hex socket head	SHWH: slotted hex washer head
CARR: carriage	HWH: hex washer head	SPH: slotted pan head
CCW: counter clockwise	HWTF: hex washer head thread forming	SQH: square head
CW: clockwise	HYD: hydraulic	SRH: slotted round head
DEG: degrees	LH: left hand	STD: standard
DPA: Dual Point Adjustment	LP: Liquid Propane	TAP: self tapping
ECM: electronic control module	NI: nylon insert	TTH: torx truss head
EXT: external	NPTF: national pipe thread fine	
FH: flat head	PFH: phillips flat head	
GA: gauge	PPH: phillips pan head	
HD: heavy-duty	PPHTF: phillips pan head thread forming	
HF: hex flange	PRH: phillips round head	
HH: hex head	PTH: phillips truss head	
HHF: hex head flange	PTO: power-take-off	
HHFTF: hex head flange thread forming	RH: right hand	
HJ: hex jam	ROPS: roll-over protection system	
HLH: hex lag head		

Touch Up Paint

Exmark black touch up spray paint – gloss black.

Exmark red touch up paint (spray paint – P/N 1-850337 - .6 oz liquid bottle – P/N 103-9140).

EXMARK PARTS PLUS

PARTS

OVERNIGHT

OR *FREE**

If your Exmark dealer does not have the Exmark part in stock, Exmark will get the parts to the dealer the next business day or the part will be FREE Guaranteed!! (Some restrictions apply. See your participating Exmark Dealer for details.)

Contents

Gear Case Assembly - 116-0103.....	5
Deck And Wheel Assembly.....	6
Handle Assembly.....	8
Bag and Door Assembly.....	9
Blade Assembly.....	10
Engine Assembly.....	11
Decals.....	12

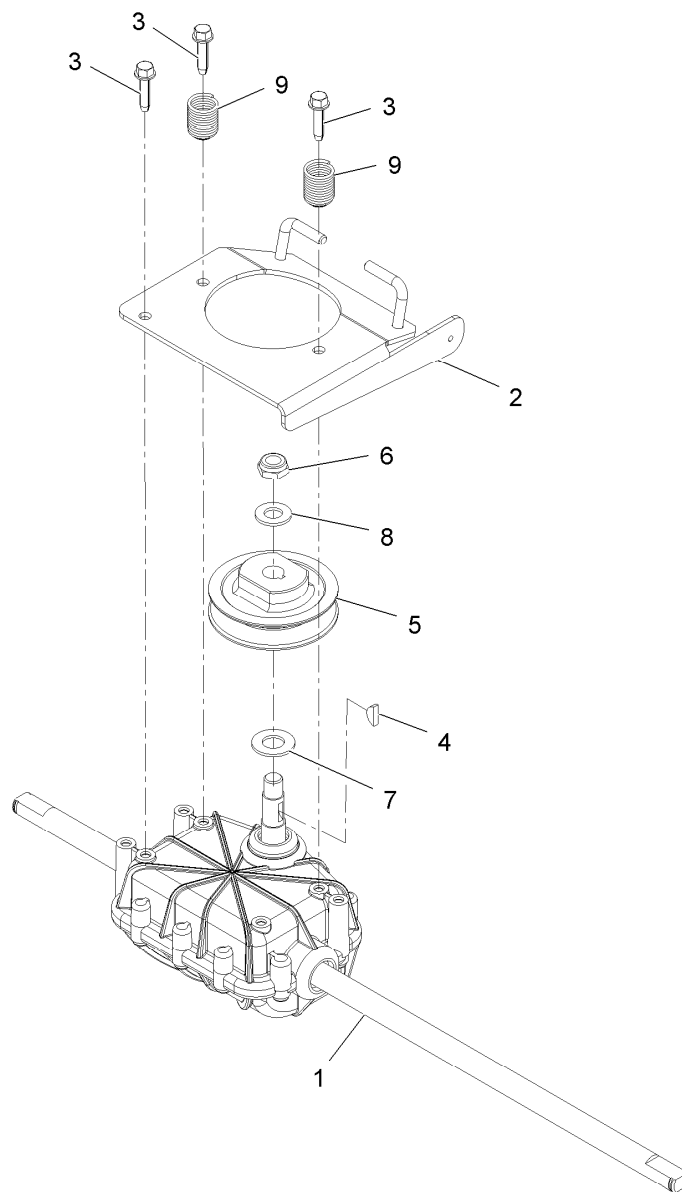

Gear Case Assembly - 116-0103

Ref.	Part Number	Qty.	Description
1	109-9290	1	Transmission,P21 4.5/1
2	116-3539-03	1	Transmission Plate ASM
3	27-0220	3	Screw-Special
4	3257-1	1	Key-Woodruff 1/8 X 1/2
5	39-6740	1	Pulley
6	3296-5	1	Nut-Nyloc 3/8-24 Thin
7	36-4792	1	Washer-Thrust
8	3256-45	1	Washer-Flat
9	116-1438	2	Spring,Compression

Deck And Wheel Assembly

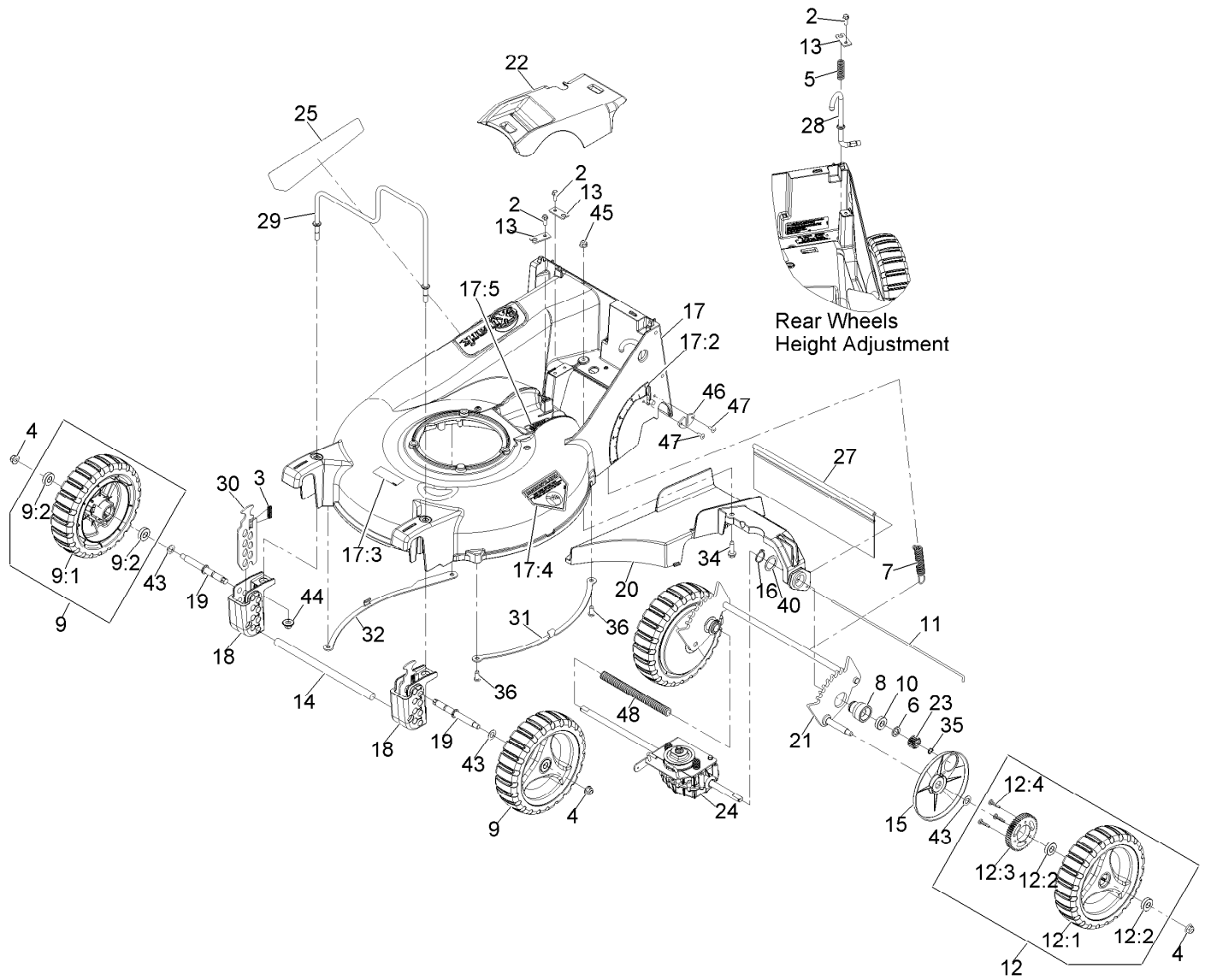

Deck And Wheel Assembly (continued)

<i>Ref.</i>	<i>Part Number</i>	<i>Qty.</i>	<i>Description</i>	<i>Ref.</i>	<i>Part Number</i>	<i>Qty.</i>	<i>Description</i>
2	32144-85	3	Screw-HWH 1/4-20 X .62	18	109-9302	2	Block,Front Quadrant
3	109-7258	2	Spring-Compression	19	116-0994	2	Axle,Wheel
4	104-8301	4	Nut-Nyloc 3/8-16 Flg	20	109-9310-01	1	Bkt,Trans Support/Chute
5	109-7694	1	Spring-Compression	21	109-9312	1	Wld,Rear Axle P21
6	108-5059	2	Spacer-Bushing	22	109-9324	1	Cover,Belt
7	109-7692	1	Spring-Extension	23	110-9417	2	Gear-Pinion, 15T
8	109-7274	2	Housing,Bearing	24	116-0103	1	ASM,Transmission W/Bracket
9	109-8016	2	ASM,Wheel And Tire With Bearing	25	116-4385	1	Decal-Comm 21 X-Series
9:1	109-8033	1	ASM,Wheel 9"	27	116-0252	1	Shield-Trailing P21
9:2	109-8020	2	Bearing-Ball	28	116-0329	1	Rod-Height Adj P21
10	109-8020	2	Bearing-Ball	29	116-0522	1	Guard,Engine
11	109-8025	1	Rod,Shield	30	109-9292	2	Plate, Front Height
12	109-8032	2	ASM,Rear Wheel 9"	31	116-0995-03	1	Skid,LH
12:1	109-8033	1	ASM,Wheel 9"	32	116-0996-03	1	Skid,RH
12:2	109-8020	2	Bearing-Ball	34	32144-49	1	Screw-HWH 5/16-18 1 1/4 Tf
12:3	109-7264	1	Gear	35	32151-61	2	Ring-Retaining
12:4	27-6260	3	Screw-Drive	36	613381	4	Screw-Button Head 5/16-18 X .725 Tf
13	109-8441	3	Bracket,Mount	40	74-1810	2	Washer
14	109-8454	1	Rod,Bumper	43	36-4780	4	Washer
15	109-9287	2	Cover,Gear	44	109-6658	2	Nut-Nyloc 3/8-16 Flg
16	32151-36	2	Ring-Retaining	45	104-8300	1	Nut-Nyloc 5/16-18 Flg
17	116-2006	1	Deck W/Decals	46	116-2221	1	Plate,Wear
17:2	116-1922	1	Decal-Height Of Cut	47	114439	2	Rivet
17:3	68-7410	1	Decal-Blade	48	117-5260	1	Cover-Shaft, Drive
17:4	94-8072	1	Decal-Danger				
17:5	109-9317	1	Decal-Cover Missing				

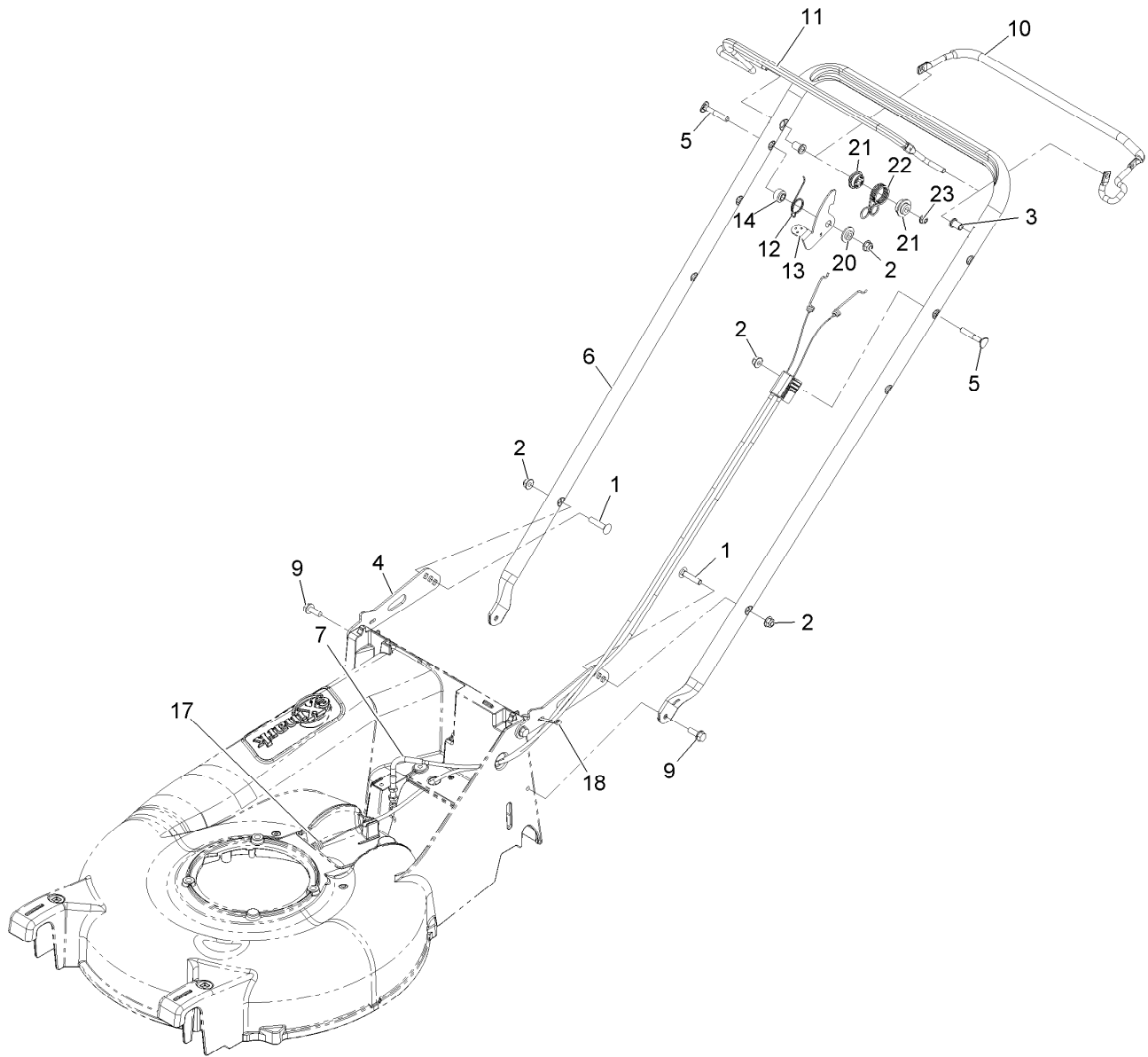

Handle Assembly

Ref.	Part Number	Qty.	Description	Ref.	Part Number	Qty.	Description
1	33-5790	2	Bolt-Carriage 5/16-18 X 1 1/2	11	109-8442	1	Bail, Opc/BBC Coated
2	104-8300	4	Nut-Nyloc 5/16-18 Flg	12	109-9318	1	Spring, BBC Lever
3	116-1478	2	Bushing-Handlebar	13	116-2998	1	Lever-BBC
4	109-9323-03	2	Bracket, Handlebar	14	116-2690	1	Bushing, Stepped
5	112-8876	2	Bolt-Carriage 5/16-18 X 2	17	116-0901	1	Cable-BBC
6	116-0119-03	1	Handlebar-P21	18	614249	1	Strap-Tie
7	116-0904	1	Cable-Drive	20	105-3006	1	Washer-Stepped
9	32144-41	4	Screw-HWH 3/8-16 X 7/8 Taptite	21	109-8457	2	Bushing, Spring Pivot
10	109-8443	1	Bail, Drive Coated	22	109-9293	1	Spring, BBC Return
				23	104-7201	1	Nut-Nyloc 1/4-20 Flg

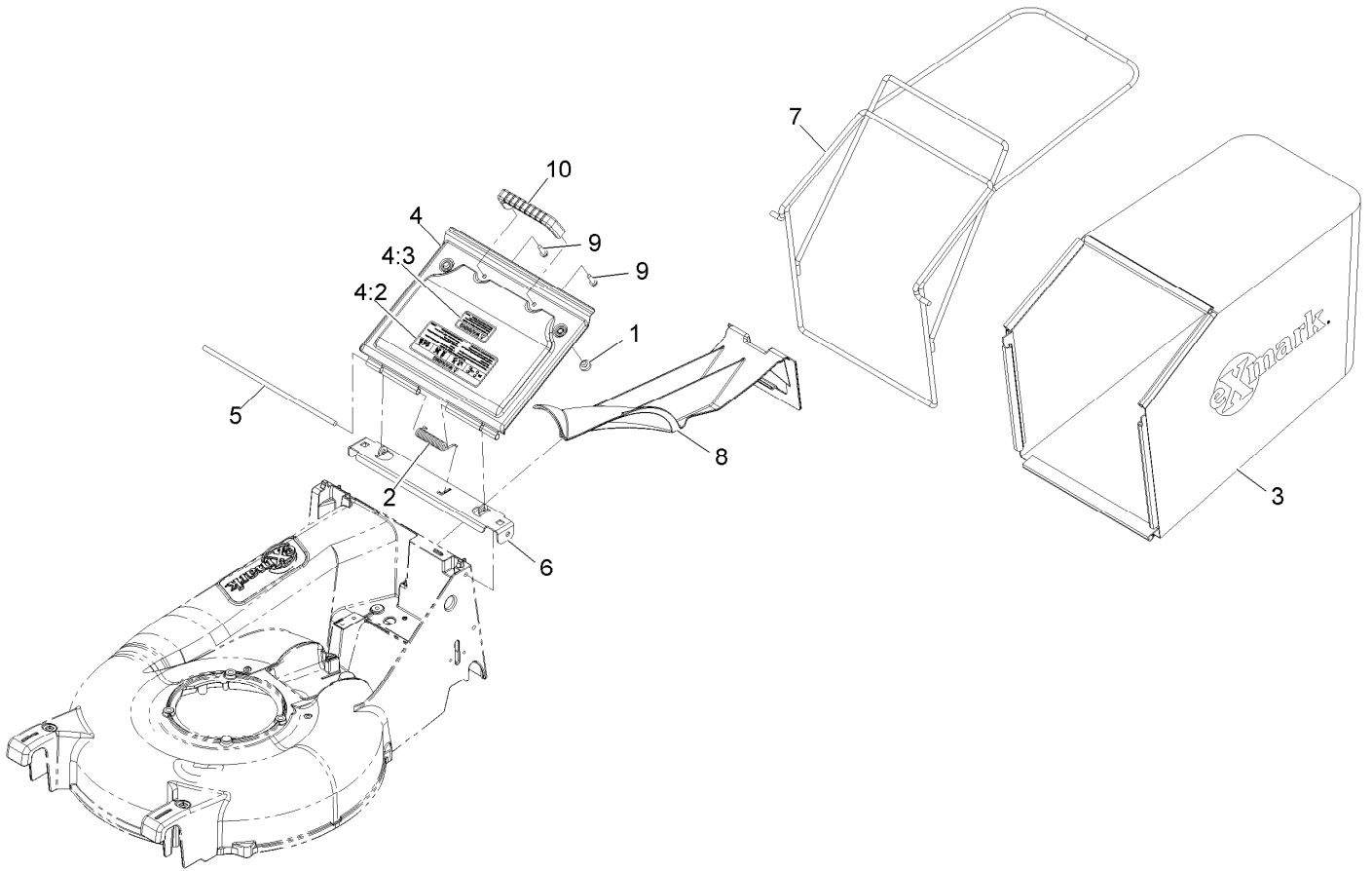

Bag and Door Assembly

Ref.	Part Number	Qty.	Description
1	1-513658	2	Bumper
2	109-7696	1	Spring-Torsion,Cover
3	109-7294	1	Bag,Grass P21
4	116-2007	1	Door W/Decal
4:2	116-1900	1	Decal-Warning
4:3	116-2685	1	Decal-Warning Door Sm
5	109-9321	1	Rod,Door Pivot
6	109-9322-03	1	Bracket-Door P21
7	109-9325-03	1	Wld,Bag Frame
8	116-0251	1	Plug,Mulch
9	46-8091	2	Screw-HWH 1/4-10 X .82 Plastite
10	65-5100	1	Handle-Door

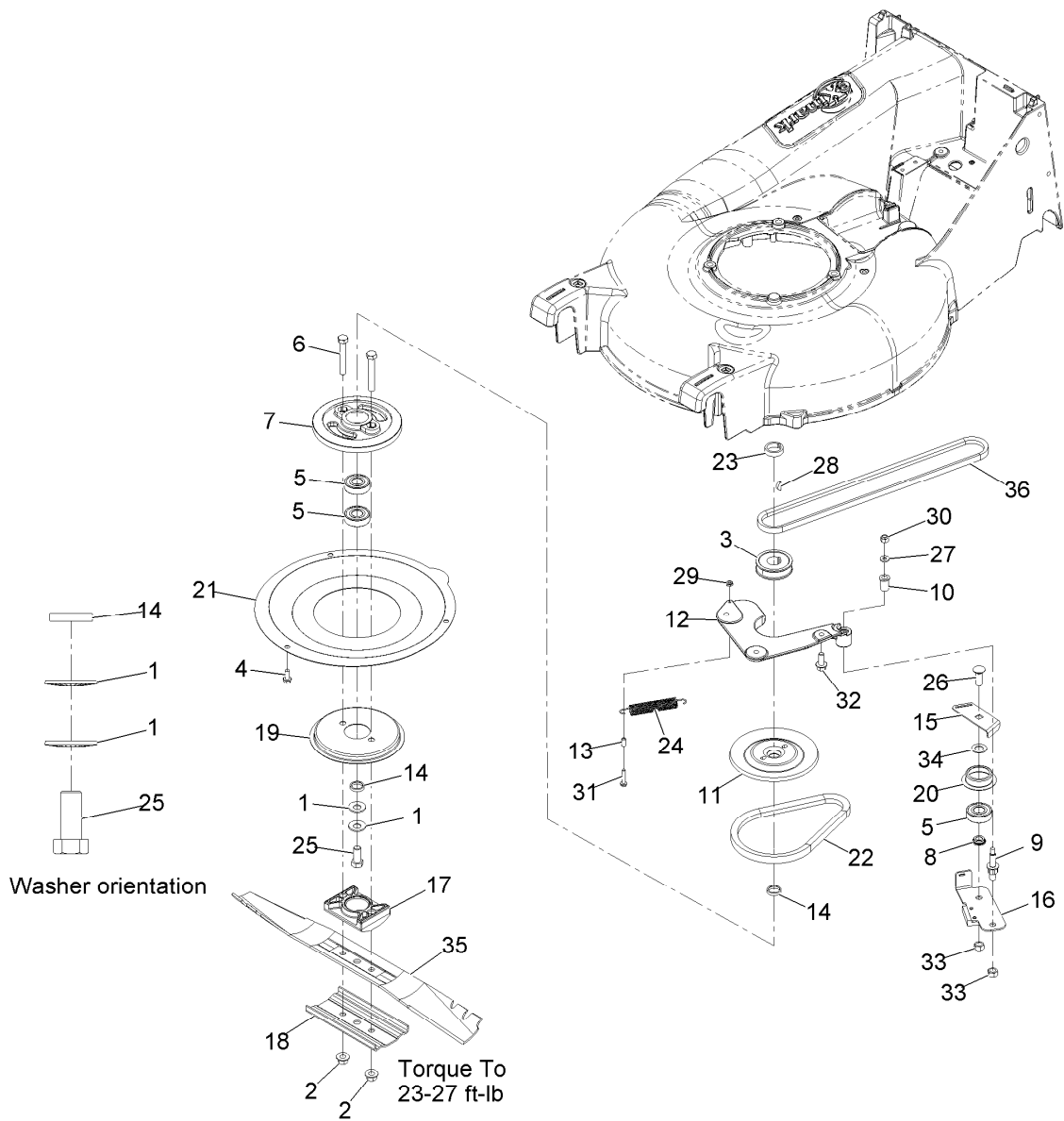

Blade Assembly

Ref.	Part Number	Qty.	Description
1	1-603610	2	Washer-Spring Disc 7/16
2	54-9190	2	Nut-Hex 3/8-24 Lock
3	56-6180	1	Pulley-Driver
4	32144-85	3	Screw-HWH 1/4-20 X .62
5	100-1048	3	Bearing-Ball
6	3211-42	2	Screw-HH 3/8-24 X 2 1/2
7	107-0754	1	Drum
8	107-0758	1	Spacer-Bearing
9	107-0759	1	Bolt-Shoulder
10	107-0797	1	Bushing
11	107-4277	1	Pulley- Driver, Upper
12	116-3572	1	Plate-Mounting, BBC
13	107-4292	1	Spacer-BBC
14	107-4293	2	Spacer-Plate, BBC
15	107-7471	1	Plate-Guide
16	107-7477	1	Brake Arm ASM
17	107-7487	1	Support-Blade
18	108-3766-03	1	Support-Blade
19	108-3787	1	Disc

Ref.	Part Number	Qty.	Description
20	108-3790	1	Retainer-Belt
21	116-3360-03	1	Cover-BBC
22	110-1790	1	Belt-BBC
23	110-2142	1	Spacer-Pulley
24	115-4471	1	Spring-Extension
25	3212-4	1	Screw-HH 7/16-20 X 1 ●
26	3231-38	1	Bolt-Carriage 3/8-16 X 1 1/4
27	3256-16	1	Washer-#12 Std
28	3257-17	1	Key-Woodruff 5/32 X 21/32
29	3296-27	1	Nut-Lock #10-32
30	3296-42	1	Nut-Nyloc 1/4-20
31	32144-9	1	Screw-HWH #10-32 X 1 Taptite
32	33104-020	3	Screw-HH M8-1.25 X 20Mm ●
33	603773	2	Nut-Hex 3/8-16 Side Lock
34	605256	1	Washer-Plain
35	108-0954-03	1	Blade-21 Inch
36	109-7299	1	Belt,3L P21 Drive

● Use Pro-Lock, Nut Type (P/N 1-840022, .5ml tube) on threads.

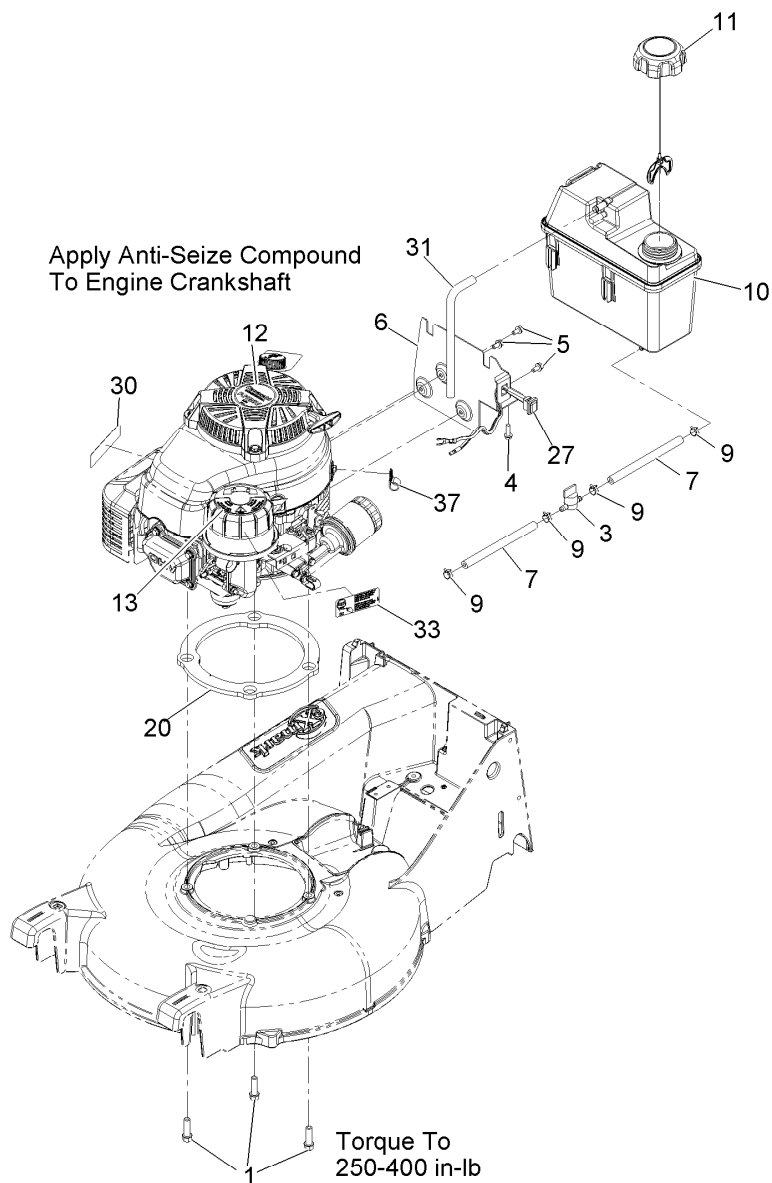

Engine Assembly

Ref.	Part Number	Qty.	Description	Ref.	Part Number	Qty.	Description
1	95-1727	3	Screw-HWH 3/8-16 X 1 1/4 Taptite	10	114-0280	1	Tank-Fuel
3	1-603770	1	Valve-Fuel	11	109-6776	1	Cap-Ratchet, Tethered
4	46-8091	1	Screw-HWH 1/4-10 X .82 Plastite	12	109-6528	1	Decal, Recoil Kai
5	104-2628	3	Screw-HWH M6-1 X 12Mm Tf ●	13	114-3415	1	Decal-Air Cleaner
6	109-9291-03	1	Bracket,Fuel Tank	20	116-2068	1	Gasket,Deck
7	107-0588	2	Hose-Fuel	27	116-2806	1	Harness,Run/Stop
9	2412-98	4	Clamp-Hose	30	117-2718	1	Decal-Arrester, Spark
				31	115-0962	1	Hose-Vent, Canister
				33	109-8191	1	Decal, Primer
				37	1-513762	1	Clip-Loom 1/2

● Use Pro-Lock, Nut Type (P/N 1-840022, .5ml tube) on threads.

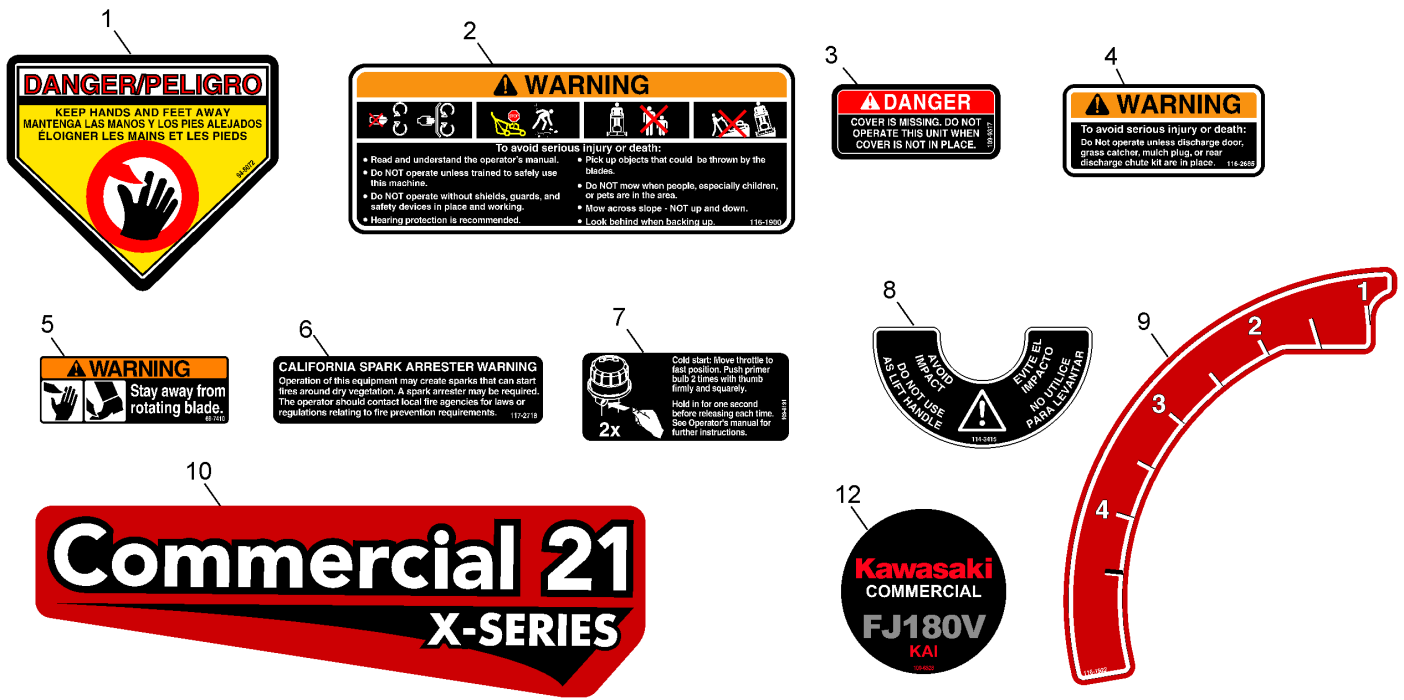

Decals

Ref.	Part Number	Qty.	Description
1	94-8072	1	Decal-Danger
2	116-1900	1	Decal-Warning
3	109-9317	1	Decal-Cover Missing
4	116-2685	1	Decal-Warning Door Sm
5	68-7410	1	Decal-Blade
6	117-2718	1	Decal-Arrester, Spark
7	109-8191	1	Decal, Primer
8	114-3415	1	Decal-Air Cleaner
9	116-1922	1	Decal-Height Of Cut
10	116-4385	1	Decal-Comm 21 X-Series
12	109-6528	1	Decal, Recoil Kai

Notes:

Notes:

Notes:

SEE EXMARK'S COMPLETE LINE OF ACCESSORIES AND OPTIONS

MID-MOUNT RIDING ACCESSORIES AND OPTIONS

CUSTOM RIDE SEAT SUSPENSION SYSTEM	OPERATOR CONTROLLED DISCHARGE
FULL SUSPENSION SEAT	ROLL OVER PROTECTION SYSTEM (ROPS)
DECK LIFT ASSIST KIT	SUN SHADE
HITCH KIT	TRASH CONTAINER
LIGHT KIT	TURF STRIPER
12V POWER PORT	ULTRA VAC COLLECTION SYSTEM
MICRO-MULCH SYSTEM	ULTRA VAC QUICK DISPOSAL SYSTEM

OUT-FRONT RIDING ACCESSORIES AND OPTIONS

CUSTOM RIDE SEAT SUSPENSION SYSTEM	SNOW BLADE
DUAL-TAIL WHEEL	SNOWBLOWER
FLOOR PAN EXTENDER	SUN SHADE
HITCH KIT	TRASH CONTAINER
LIGHT KIT	ULTRA VAC COLLECTION SYSTEM
MICRO-MULCH SYSTEM	ULTRA VAC QUICK DISPOSAL SYSTEM
ROLL OVER PROTECTION SYSTEM (ROPS)	WEATHER CAB

WALK-BEHIND ACCESSORIES AND OPTIONS

GRASS CATCHER	TURF STRIPER
MICRO-MULCH SYSTEM	STANDON

Place Model No. and Serial No.
Label Here (Included in the Literature
Pack) or Fill in Below

Model No. _____

Serial No. _____

Date Purchased _____

Engine Model No. and Spec. No. _____

Engine Serial No. (E/No) _____

© 2011 Exmark Mfg. Co., Inc.
Industrial Park Box 808
Beatrice, NE 68310
All Rights Reserved

Part No. 4500-823 Rev. B
(402) 223-6300
Fax (402) 223-5489
Printed in the USA.

