

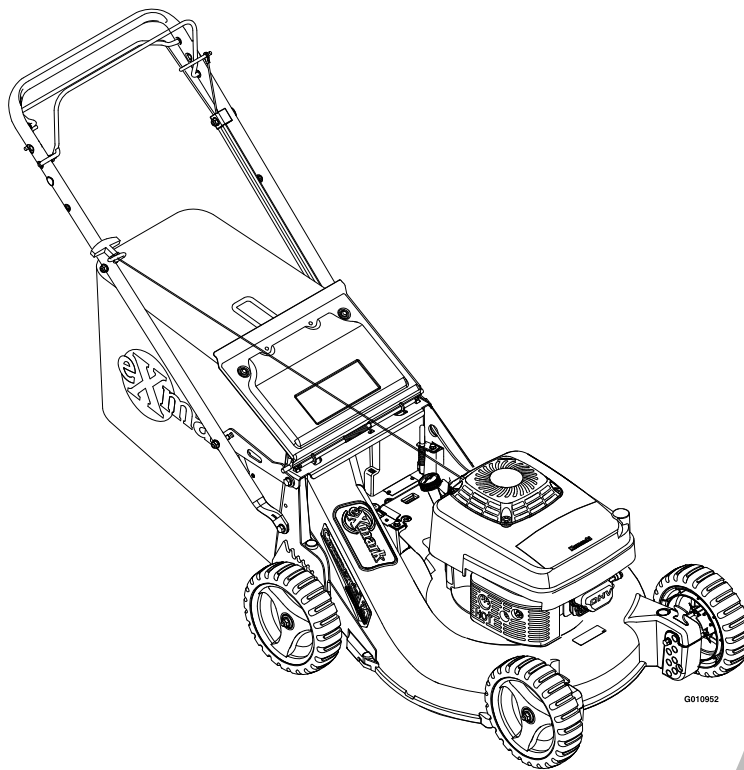

# COMMERCIAL 21

Model No. ECSKA21—Serial No. 920000 and Up

Picture below may not reflect actual product.



# Parts Manual

Part No. 4500-819 Rev. B

# Ordering Replacement Parts

To order replacement parts, please supply the part number, the quantity, and the description of each part desired.

## Understanding Reference Numbers

Each identified part in an illustration has a reference number. The reference number for a part also appears in the parts list, along with other information about the part.

This catalog uses two special reference number formats, one to indicate parts in a service assembly and another to indicate the quantity of a given part in an illustration.

## Service Assembly Reference Numbers

Parts in service assemblies have reference numbers in the form a:b. The a represents the reference number of the entire service assembly and the b represents a sequential number unique to each part within the service assembly.

For example, a wheel assembly might be identified by reference number 6, the tire by 6:1, the valve by 6:2, and the wheel by 6:3. When you order the assembly identified by reference number 6, you receive all parts identified by reference numbers 6:1, 6:2, and 6:3. However, you may also order any part individually. Reference numbers of this type appear in illustration and in parts lists.

## Reference Numbers Indicating Quantity

In an illustration, if a reference number indicates more than one part, the reference number has the form nX y. The n represents the quantity of the part, the X is the multiplication symbol, and the y represents the reference number.

For example, in an illustration, the reference number 2X 37 means that two of the parts identified by reference number 37 are indicated.

# List of Abbreviations

<b>AR:</b> as required	<b>HOC:</b> height-of-cut	<b>RRB:</b> rear roller brush
<b>ASM:</b> assembly	<b>HSBH:</b> hex socket button head	<b>SFH:</b> slotted fillister head
<b>BBC:</b> blade brake control	<b>HSFH:</b> hex socket flat head	<b>SHH:</b> slotted hex head
<b>BHTF:</b> button head thread forming	<b>HSH:</b> hex socket head	<b>SHWH:</b> slotted hex washer head
<b>CARR:</b> carriage	<b>HWH:</b> hex washer head	<b>SPH:</b> slotted pan head
<b>CCW:</b> counter clockwise	<b>HWTF:</b> hex washer head thread forming	<b>SQH:</b> square head
<b>CW:</b> clockwise	<b>HYD:</b> hydraulic	<b>SRH:</b> slotted round head
<b>DEG:</b> degrees	<b>LH:</b> left hand	<b>STD:</b> standard
<b>DPA:</b> Dual Point Adjustment	<b>LP:</b> Liquid Propane	<b>TAP:</b> self tapping
<b>ECM:</b> electronic control module	<b>NI:</b> nylon insert	<b>TTH:</b> torx truss head
<b>EXT:</b> external	<b>NPTF:</b> national pipe thread fine	
<b>FH:</b> flat head	<b>PFH:</b> phillips flat head	
<b>GA:</b> gauge	<b>PPH:</b> phillips pan head	
<b>HD:</b> heavy-duty	<b>PPHTF:</b> phillips pan head thread forming	
<b>HF:</b> hex flange	<b>PRH:</b> phillips round head	
<b>HH:</b> hex head	<b>PTH:</b> phillips truss head	
<b>HHF:</b> hex head flange	<b>PTO:</b> power-take-off	
<b>HHFTF:</b> hex head flange thread forming	<b>RH:</b> right hand	
<b>HJ:</b> hex jam	<b>ROPS:</b> roll-over protection system	
<b>HLH:</b> hex lag head		

# Touch Up Paint

Exmark black touch up spray paint – gloss black.

Exmark red touch up paint (spray paint – P/N 1-850337 - .6 oz liquid bottle – P/N 103-9140).

**EXMARK PARTS PLUS**

***PARTS***

**OVERNIGHT**

**OR *FREE*\***

If your Exmark dealer does not have the Exmark part in stock, Exmark will get the parts to the dealer the next business day or the part will be FREE Guaranteed!! (Some restrictions apply. See your participating Exmark Dealer for details.)

# Contents

- Gear Case Assembly - 116-0103..... 5
- Deck and Wheel Assembly..... 6
- Handle Assembly..... 8
- Bag and Door Assembly..... 9
- Blade Assembly..... 10
- Engine Assembly..... 11
- Decals..... 12

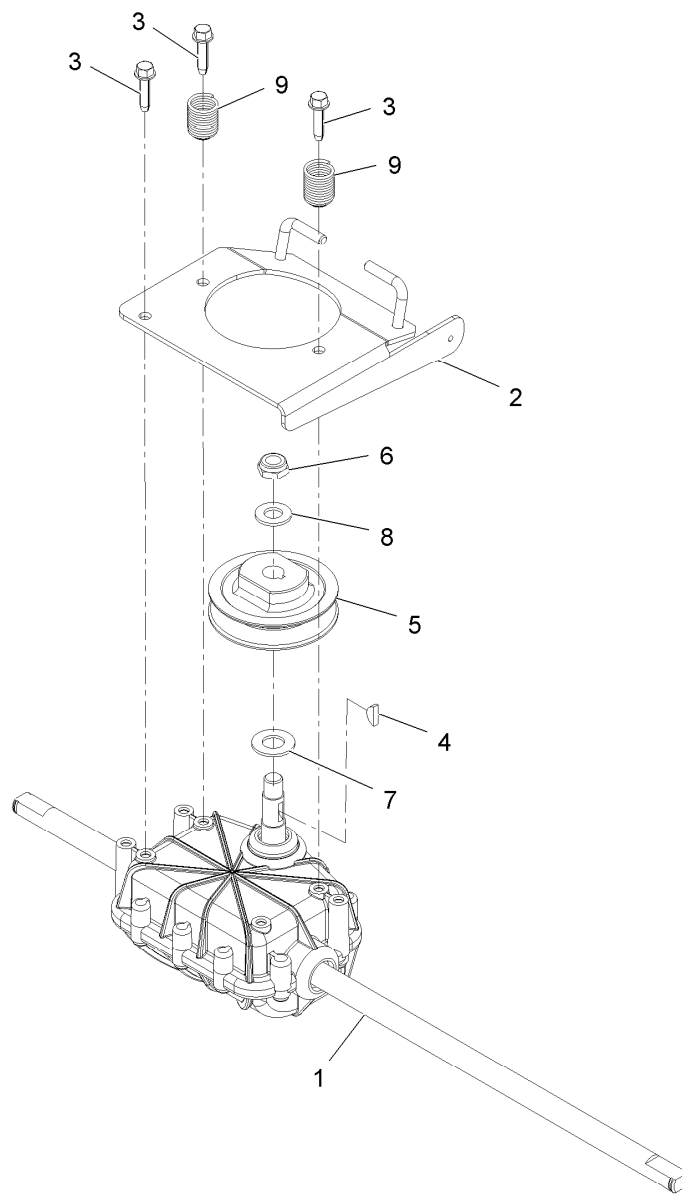

## Gear Case Assembly - 116-0103

Ref.	Part Number	Qty.	Description
1	109-9290	1	Transmission,P21 4.5/1
2	116-3539-03	1	Transmission Plate ASM
3	27-0220	3	Screw-Special
4	3257-1	1	Key-Woodruff 1/8 X 1/2
5	39-6740	1	Pulley
6	3296-5	1	Nut-Nyloc 3/8-24 Thin
7	36-4792	1	Washer-Thrust
8	3256-45	1	Washer-Flat
9	116-1438	2	Spring,Compression

# Deck and Wheel Assembly

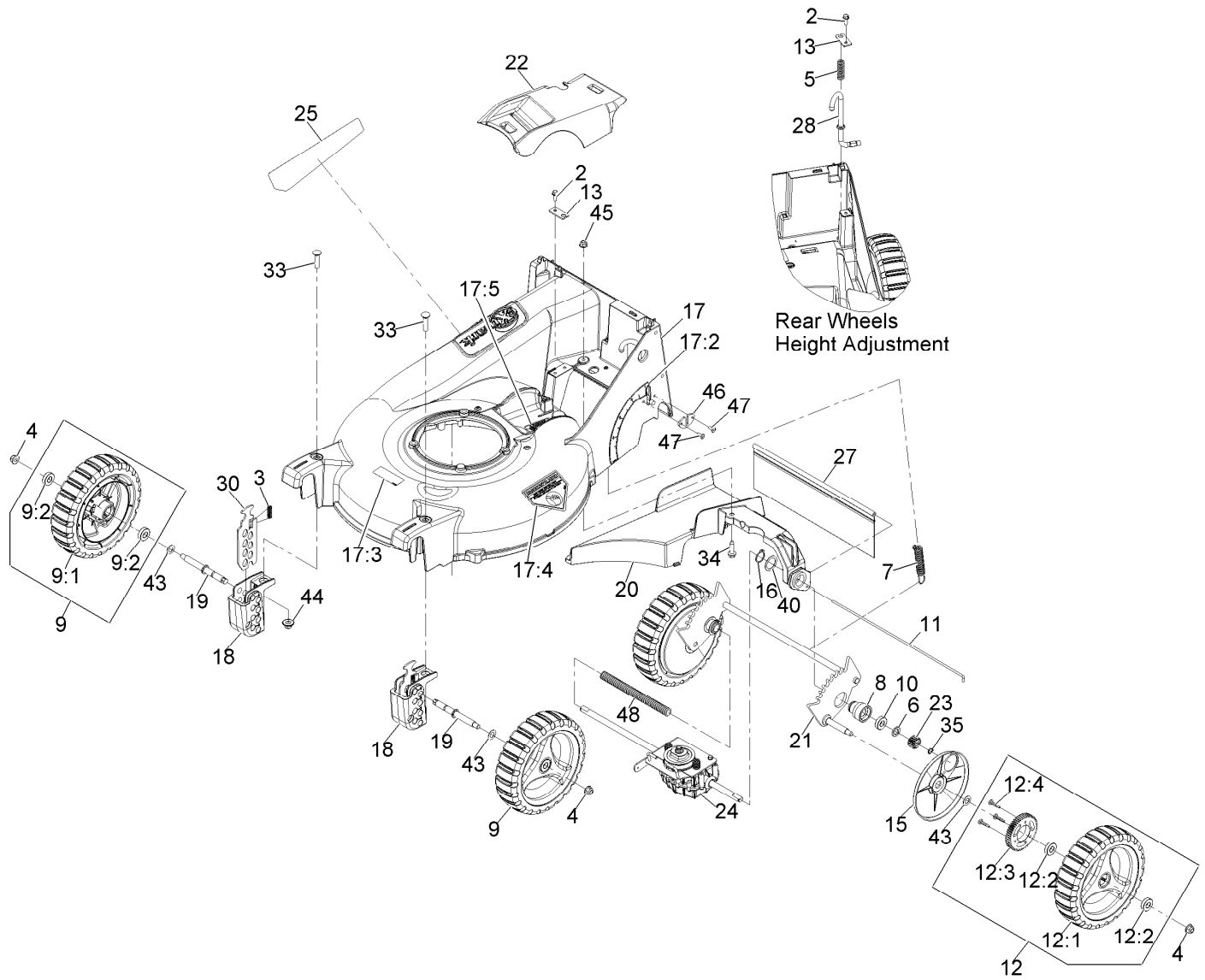

## Deck and Wheel Assembly (continued)

<i>Ref.</i>	<i>Part Number</i>	<i>Qty.</i>	<i>Description</i>	<i>Ref.</i>	<i>Part Number</i>	<i>Qty.</i>	<i>Description</i>
2	32144-85	2	Screw-HWH 1/4-20 X .62	17:5	109-9317	1	Decal-Cover Missing
3	109-7258	2	Spring-Compression	18	109-9302	2	Block,Front Quadrant
4	104-8301	4	Nut-Nyloc 3/8-16 Flg	19	116-0994	2	Axle,Wheel
5	109-7694	1	Spring-Compression	20	109-9310-01	1	Bkt,Trans Support/Chute
6	108-5059	2	Spacer-Bushing	21	109-9312	1	Wld,Rear Axle P21
7	109-7692	1	Spring-Extension	22	109-9324	1	Cover,Belt
8	109-7274	2	Housing,Bearing	23	110-9417	2	Gear-Pinion, 15T
9	109-8016	2	ASM,Wheel And Tire With Bearing	24	116-0103	1	ASM,Transmission W/Bracket
9:1	109-8033	1	ASM,Wheel 9"	25	116-4362	1	Decal-Comm 21 S-Series
9:2	109-8020	2	Bearing-Ball	27	116-0252	1	Shield-Trailing P21
10	109-8020	2	Bearing-Ball	28	116-0329	1	Rod-Height Adj P21
11	109-8025	1	Rod,Shield	30	109-9292	2	Plate, Front Height
12	109-8032	2	ASM,Rear Wheel 9"	33	109-8449	2	Bolt-Carriage 3/8-16 X 1 1/2
12:1	109-8033	1	ASM,Wheel 9"	34	32144-49	1	Screw-HWH 5/16-18 1 1/4 Tf
12:2	109-8020	2	Bearing-Ball	35	32151-61	2	Ring-Retaining
12:3	109-7264	1	Gear	40	74-1810	2	Washer
12:4	27-6260	3	Screw-Drive	43	36-4780	4	Washer
13	109-8441	2	Bracket,Mount	44	109-6658	2	Nut-Nyloc 3/8-16 Flg
15	109-9287	2	Cover,Gear	45	104-8300	1	Nut-Nyloc 5/16-18 Flg
16	32151-36	2	Ring-Retaining	46	116-2221	1	Plate,Wear
17	116-2006	1	Deck W/Decals	47	114439	2	Rivet
17:2	116-1922	1	Decal-Height Of Cut	48	117-5260	1	Cover-Shaft, Drive
17:3	68-7410	1	Decal-Blade				
17:4	94-8072	1	Decal-Danger				

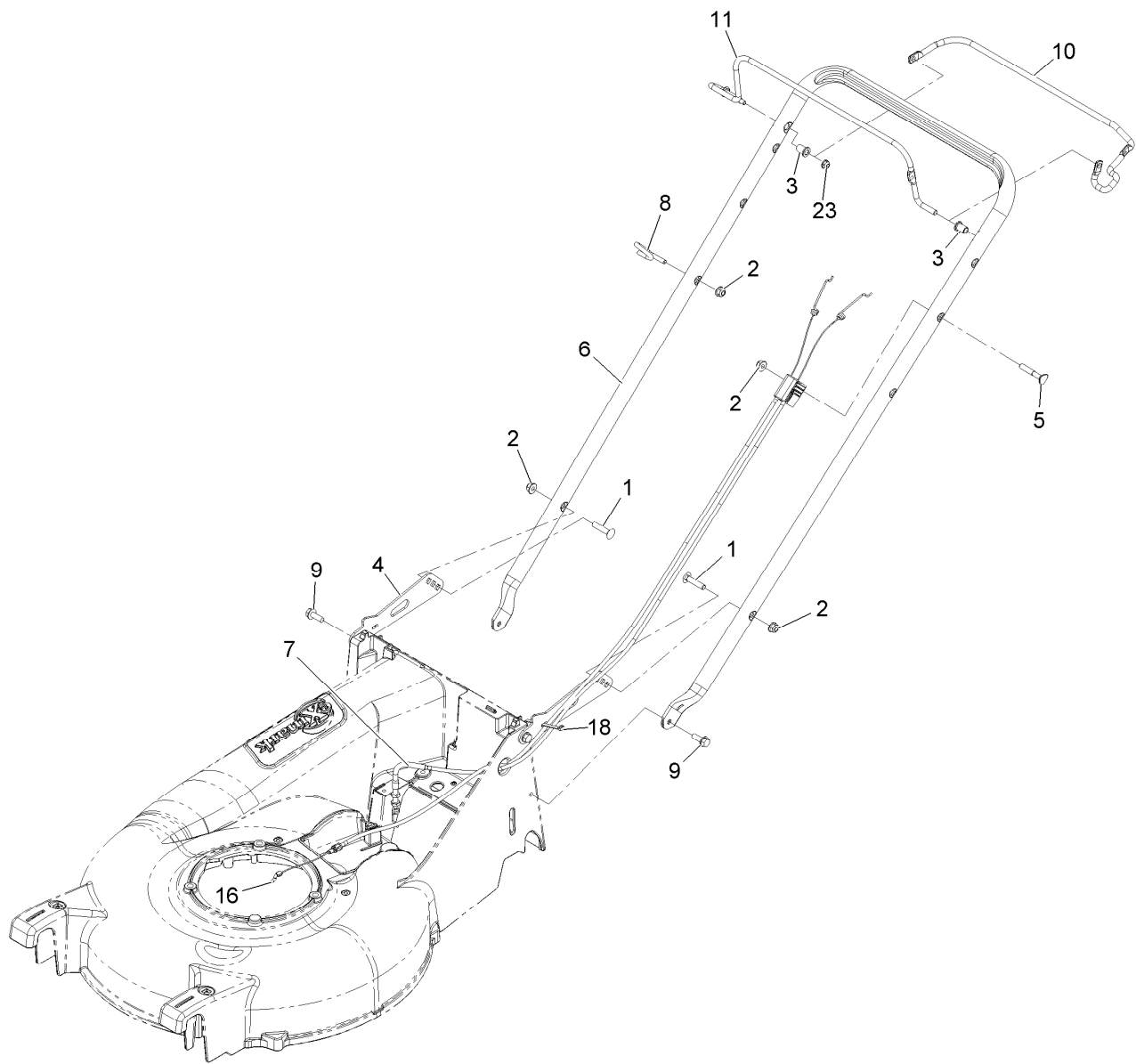

## Handle Assembly

Ref.	Part Number	Qty.	Description
1	33-5790	2	Bolt-Carriage 5/16-18 X 1 1/2
2	104-8300	4	Nut-Nyloc 5/16-18 Flg
3	116-1478	2	Bushing-Handlebar
4	109-9323-03	2	Bracket, Handlebar
5	112-8876	1	Bolt-Carriage 5/16-18 X 2
6	116-0119-03	1	Handlebar-P21
7	116-0904	1	Cable-Drive
8	116-1056	1	Guide, Rope
9	32144-41	4	Screw-HWH 3/8-16 X 7/8 Taptite
10	116-2825	1	Bail-Drive
11	116-2252	1	Bail, Opc/BBC
16	116-0905	1	Cable-Zone Kawasaki
18	614249	1	Strap-Tie
23	104-7201	1	Nut-Nyloc 1/4-20 Flg



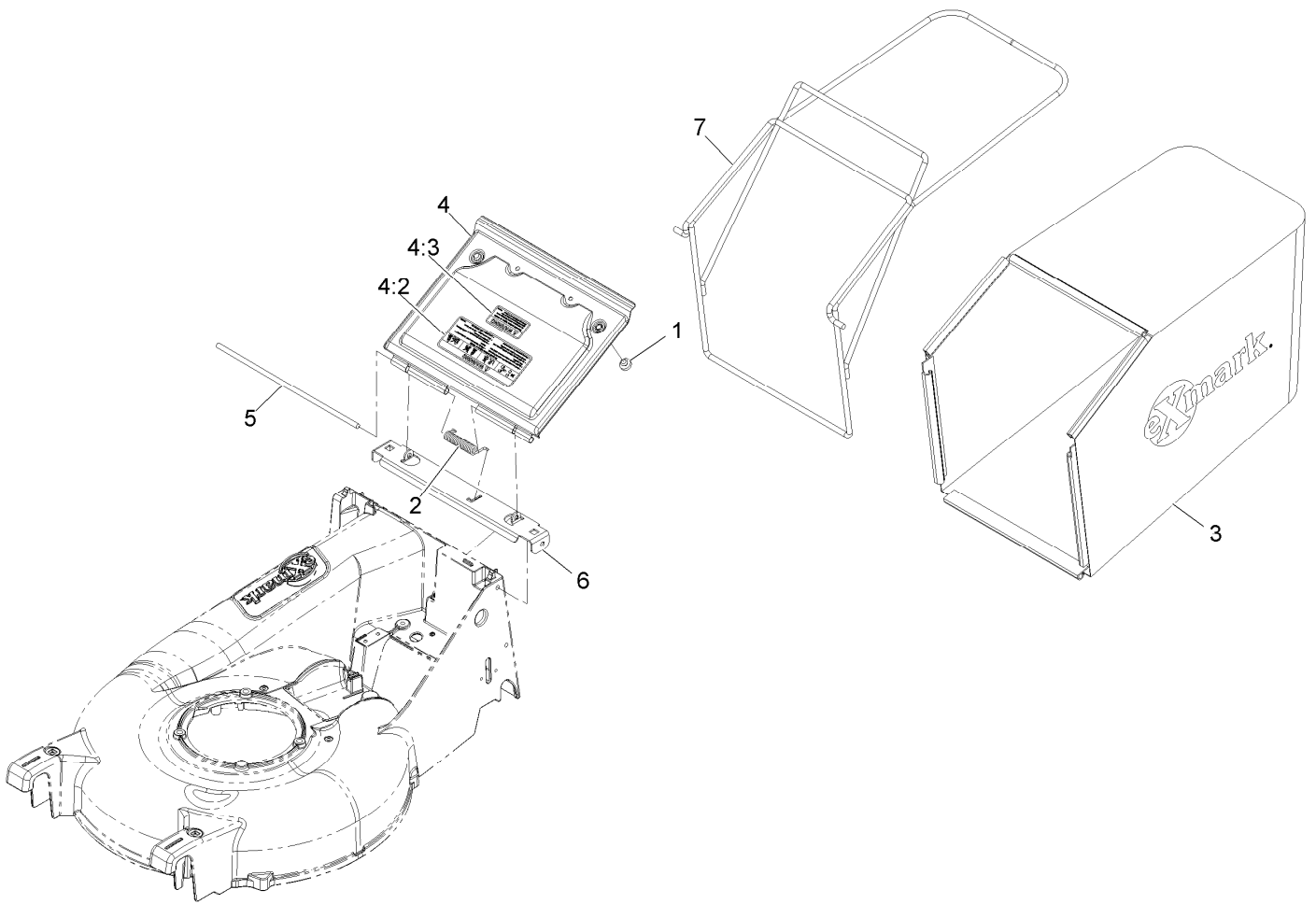

## Bag and Door Assembly

Ref.	Part Number	Qty.	Description
1	1-513658	2	Bumper
2	109-7696	1	Spring-Torsion,Cover
3	109-7294	1	Bag,Grass P21
4	116-2007	1	Door W/Decal
4:2	116-1900	1	Decal-Warning
4:3	116-2685	1	Decal-Warning Door Sm
5	109-9321	1	Rod,Door Pivot
6	109-9322-03	1	Bracket-Door P21
7	109-9325-03	1	Wld,Bag Frame

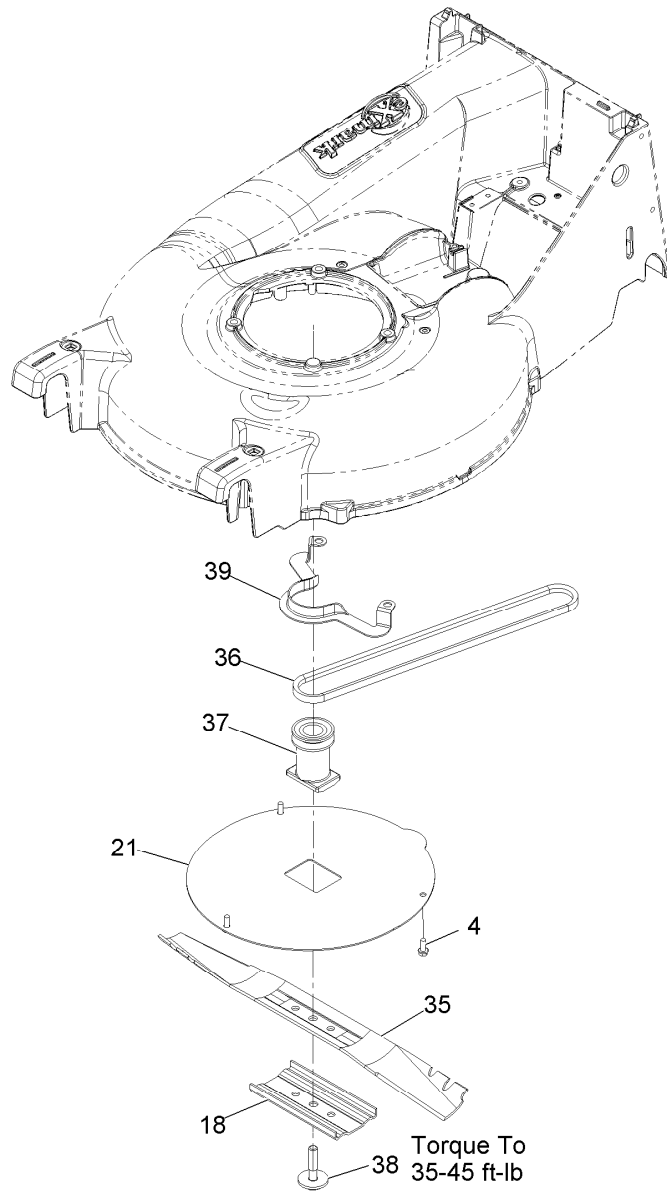

## Blade Assembly

<i>Ref.</i>	<i>Part Number</i>	<i>Qty.</i>	<i>Description</i>
4	32144-85	3	Screw-HWH 1/4-20 X .62
18	108-3766-03	1	Support-Blade
21	116-3503-03	1	Cover-As
35	108-0954-03	1	Blade-21 Inch
36	109-7299	1	Belt,3L P21 Drive
37	109-7257	1	Blade-Adapter
38	116-0005	1	Bolt,Blade Sem
39	108-8110-03	1	Guide-Belt

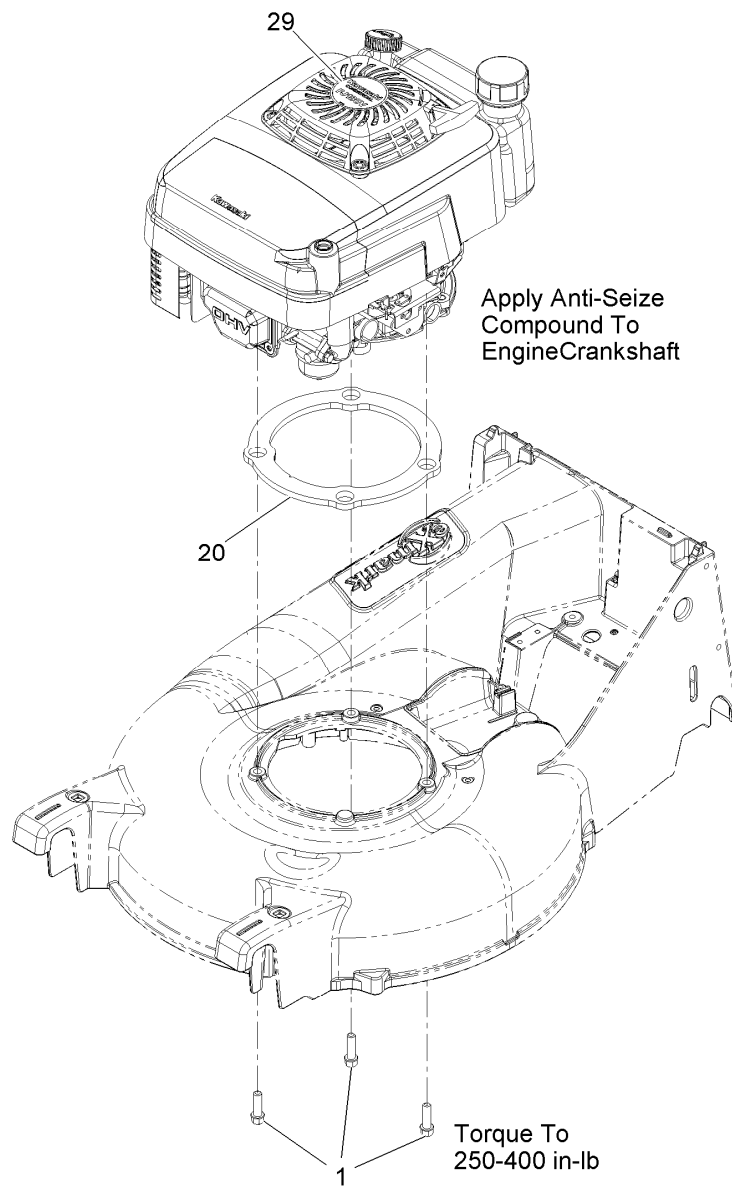

## Engine Assembly

<i>Ref.</i>	<i>Part Number</i>	<i>Qty.</i>	<i>Description</i>
1	95-1727	3	Screw-Taptite
20	116-2068	1	Gasket,Deck
29	107-4201	1	Decal-Recoil



## Decals

Ref.	Part Number	Qty.	Description
1	94-8072	1	Decal-Danger
2	116-1900	1	Decal-Warning
3	109-9317	1	Decal-Cover Missing
4	116-2685	1	Decal-Warning Door Sm
5	68-7410	1	Decal-Blade
9	116-1922	1	Decal-Height Of Cut
10	116-4362	1	Decal-Comm 21 S-Series
12	107-4201	1	Decal-Recoil

**Notes:**

**Notes:**

**Notes:**

## SEE EXMARK'S COMPLETE LINE OF ACCESSORIES AND OPTIONS

### MID-MOUNT RIDING ACCESSORIES AND OPTIONS

CUSTOM RIDE SEAT SUSPENSION SYSTEM	OPERATOR CONTROLLED DISCHARGE
FULL SUSPENSION SEAT	ROLL OVER PROTECTION SYSTEM (ROPS)
DECK LIFT ASSIST KIT	SUN SHADE
HITCH KIT	TRASH CONTAINER
LIGHT KIT	TURF STRIPER
12V POWER PORT	ULTRA VAC COLLECTION SYSTEM
MICRO-MULCH SYSTEM	ULTRA VAC QUICK DISPOSAL SYSTEM

### OUT-FRONT RIDING ACCESSORIES AND OPTIONS

CUSTOM RIDE SEAT SUSPENSION SYSTEM	SNOW BLADE
DUAL-TAIL WHEEL	SNOWBLOWER
FLOOR PAN EXTENDER	SUN SHADE
HITCH KIT	TRASH CONTAINER
LIGHT KIT	ULTRA VAC COLLECTION SYSTEM
MICRO-MULCH SYSTEM	ULTRA VAC QUICK DISPOSAL SYSTEM
ROLL OVER PROTECTION SYSTEM (ROPS)	WEATHER CAB

### WALK-BEHIND ACCESSORIES AND OPTIONS

GRASS CATCHER	TURF STRIPER
MICRO-MULCH SYSTEM	STANDON

Place Model No. and Serial No.  
Label Here (Included in the Literature  
Pack) or Fill in Below

Model No. \_\_\_\_\_

Serial No. \_\_\_\_\_

Date Purchased \_\_\_\_\_

Engine Model No. and Spec. No. \_\_\_\_\_

Engine Serial No. (E/No) \_\_\_\_\_

© 2011 Exmark Mfg. Co., Inc.  
Industrial Park Box 808  
Beatrice, NE 68310  
All Rights Reserved

Part No. 4500-819 Rev. B  
(402) 223-6300  
Fax (402) 223-5489  
Printed in the USA.

