

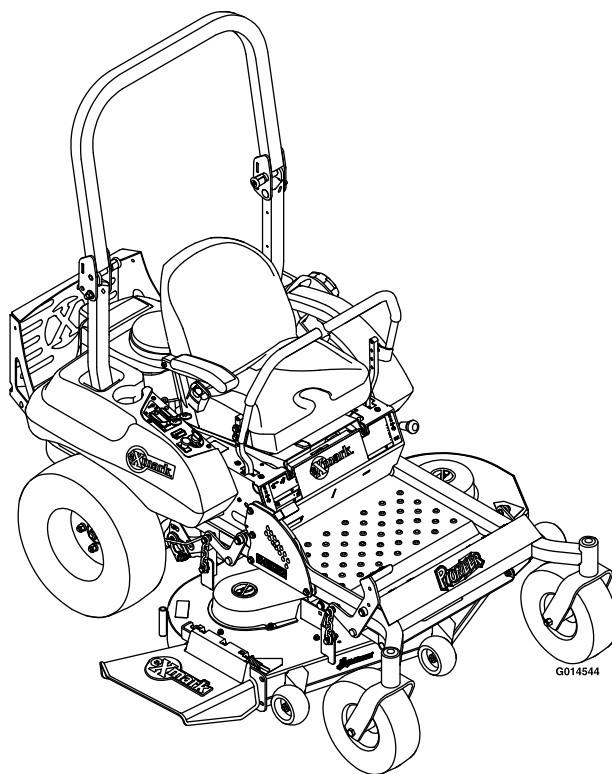

PIONEER E-SERIES

Model No. PNE651KA482—Serial No. 31200000 and Up

Picture below may not reflect actual product.



Parts Manual

Ordering Replacement Parts

To order replacement parts, please supply the part number, the quantity, and the description of each part desired.

Understanding Reference Numbers

Each identified part in an illustration has a reference number. The reference number for a part also appears in the parts list, along with other information about the part.

This catalog uses two special reference number formats, one to indicate parts in a service assembly and another to indicate the quantity of a given part in an illustration.

Service Assembly Reference Numbers

Parts in service assemblies have reference numbers in the form a:b. The a represents the reference number of the entire service assembly and the b represents a sequential number unique to each part within the service assembly.

For example, a wheel assembly might be identified by reference number 6, the tire by 6:1, the valve by 6:2, and the wheel by 6:3. When you order the assembly identified by reference number 6, you receive all parts identified by reference numbers 6:1, 6:2, and 6:3. However, you may also order any part individually. Reference numbers of this type appear in illustration and in parts lists.

Reference Numbers Indicating Quantity

In an illustration, if a reference number indicates more than one part, the reference number has the form nX y. The n represents the quantity of the part, the X is the multiplication symbol, and the y represents the reference number.

For example, in an illustration, the reference number 2X 37 means that two of the parts identified by reference number 37 are indicated.

List of Abbreviations

AR: as required	HJ: hex jam	PTH: phillips truss head
ASM: assembly	HLH: hex lag head	PTO: power-take-off
BBC: blade brake control	HOC: height-of-cut	RH: right hand
BHTF: button head thread forming	HSBH: hex socket button head	ROPS: roll-over protection system
CARR: carriage	HSFH: hex socket flat head	RRB: rear roller brush
CCW: counter clockwise	HSH: hex socket head	SFH: slotted fillister head
CW: clockwise	HWH: hex washer head	SHH: slotted hex head
DEG: degrees	HWHTF: hex washer head thread forming	SHWH: slotted hex washer head
DPA: Dual Point Adjustment	HYD: hydraulic	SPH: slotted pan head
ECM: electronic control module	LH: left hand	SQH: square head
EXT: external	LP: Liquid Propane	SRH: slotted round head
FH: flat head	NI: nylon insert	STD: standard
GA: gauge	NPTF: national pipe thread fine	TAP: self tapping
HD: heavy-duty	PFH: phillips flat head	TTH: torx truss head
HF: hex flange	PPH: phillips pan head	
HH: hex head	PPHTF: phillips pan head thread forming	
HHF: hex head flange	PRH: phillips round head	
HHFTF: hex head flange thread forming		

Touch Up Paint

Exmark black touch up spray paint – gloss black.

Exmark red touch up paint (spray paint – P/N 1-850337 - .6 oz liquid bottle – P/N 103-9140).



If your Exmark dealer does not have the Exmark part in stock, Exmark will get the parts to the dealer the next business day or the part will be FREE Guaranteed!! (Some restrictions apply. See your participating Exmark Dealer for details.)

Contents

Complete Deck Assembly No. 116-4808	4
Deck Assembly	5
Deck W/Decals Assembly No. 116-5047	6
Mainframe Assembly	7
Mainframe W/Decals Assembly No. 116-6831	8
Caster Wheel Assembly No. 120-2251.....	9
Roll-Over Protection System Assembly No. 116-3498.....	10
Deck Lift Assembly.....	11
Motion Control Assembly	12
Motion Control Assembly - LH	13
Motion Control Assembly - RH.....	14
Seat Assembly	15
Seat W/Tracks Assembly No. 116-6192.....	16
Controls Assembly	17
Fuel Tank Assembly.....	18
Fuel Tank Assembly No. 116-4610	19
Engine Assembly	20
Hydraulic Assembly	21
Transaxle Assembly.....	22
Electrical Assembly	23

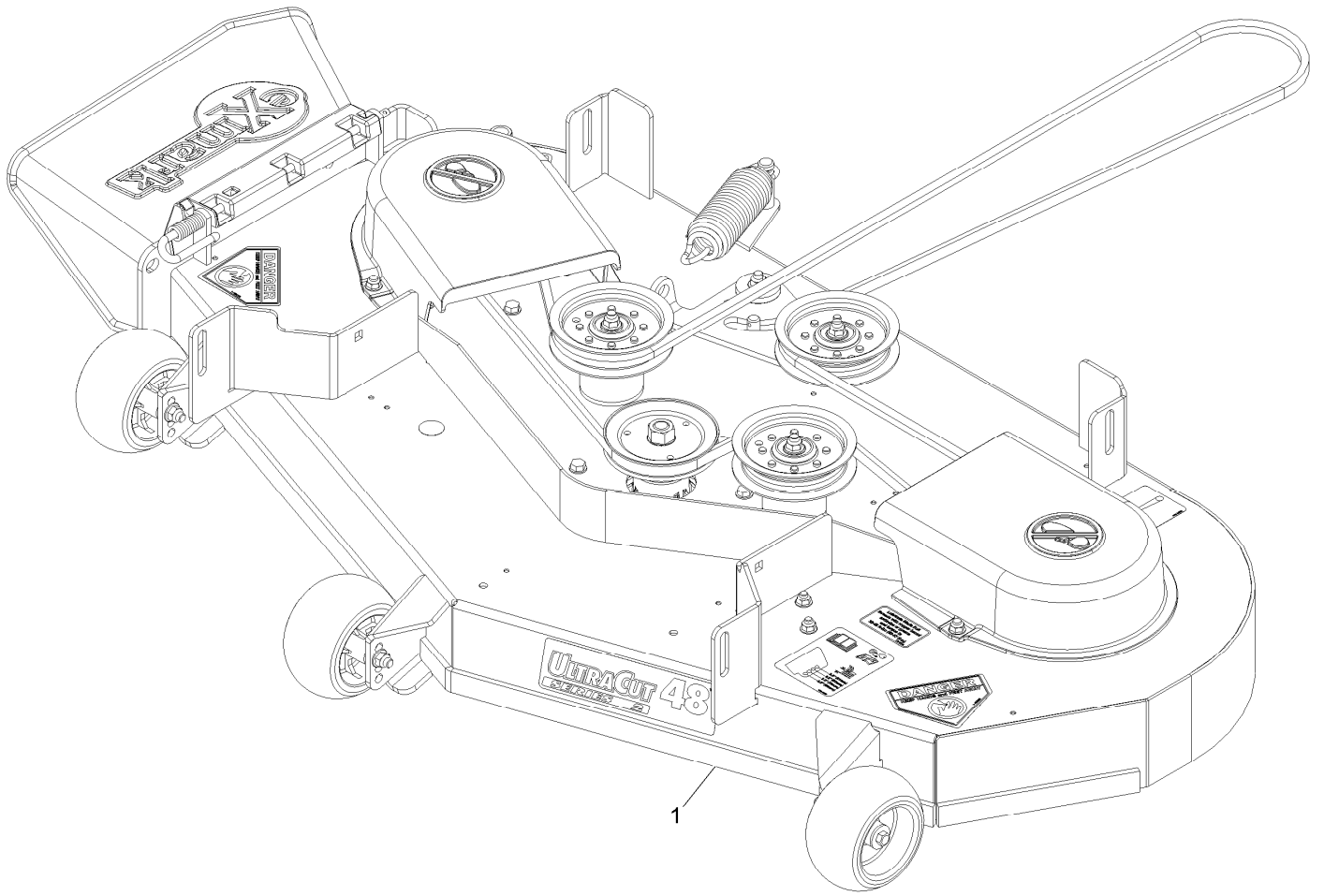

Complete Deck Assembly No. 116-4808

<i>Ref.</i>	<i>Part Number</i>	<i>Qty.</i>	<i>Description</i>
1	116-4808	1	ASM-Deck Complete 482

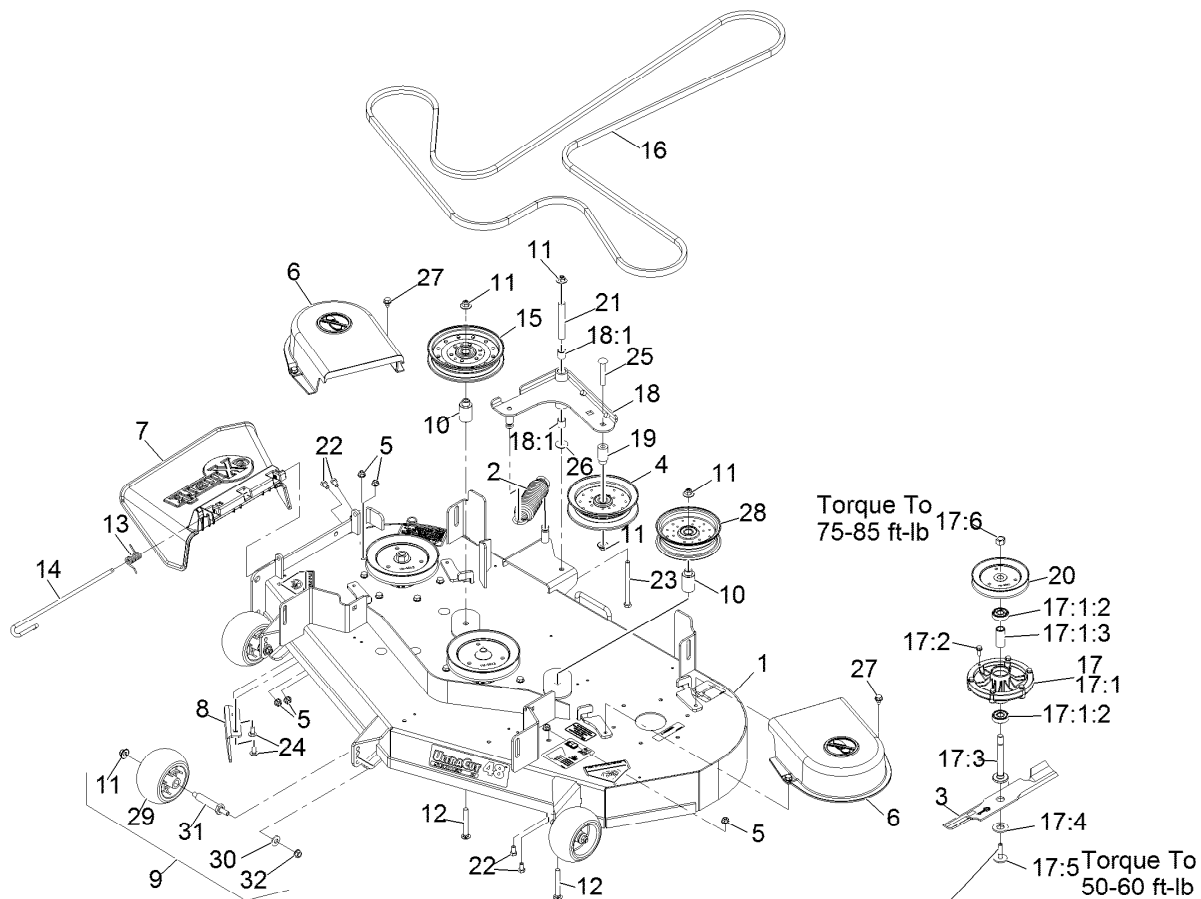

Apply lubricant to threads as needed to prevent seizing. Copper based anti-seize preferable. Grease is an acceptable substitute.

Deck Assembly

Ref.	Part Number	Qty.	Description	Ref.	Part Number	Qty.	Description
1	116-5047	1	ASM-482 Deck W/Decals	17:1:2	116-4004	2	Bearing-6303 Trash Guard
2	103-3330	1	Spring-Extension	17:1:3	116-4876	1	Spacer-Bearing
3	116-5177	3	Blade-Extreme 2, 16.25"	17:2	32144-41	6	Screw-HWH 3/8-16 X 7/8 Taptite
3	109-6389	3	Blade,Mulch 16.25 ●	17:3	109-7431	1	Spindle-Hex Pilot
3	103-6401	3	Blade-Notched	17:4	109-7429	1	Washer-Blade Drive
3	103-6386	3	Blade, Low Lift 16.25 (.94 Hole)	17:5	116-0005	1	Bolt,Blade Sem
3	103-6381	3	Blade, Solid 16.25 (.94 Hole)	17:6	3219-6	1	Nut-Hex 5/8-18
4	116-4668	1	Idler-Pulley, Flanged	18	116-4693	1	ASM-Idler Arm
5	104-8300	6	Nut-Nyloc 5/16-18 Fig	18:1	1-513034	2	Sleeve-Bearing
6	109-3449	2	Shield-Belt	19	116-4714	1	Bushing-Idler
7	109-5151	1	Deflector-Discharge	20	116-5043	3	Sheave,Blade Drive 5.90
8	109-5498-03	1	Baffle-Discharge	21	116-5111	1	Bushing
9	103-4051	3	Kit,Anti-Scalp Roller	22	322-2	4	Screw-HH 5/16-18 X 5/8
10	109-6572	2	Bushing-Idler	23	323-23	1	Screw-HH 3/8-16 X 4-1/2
11	109-6658	7	Nut-Nyloc 3/8-16 Fig	24	3230-23	2	Bolt-Carriage 5/16-18 X 3/4 Short Neck
12	109-6868	2	Bolt-Carriage 3/8-16 X 3	25	3231-44	1	Bolt-Carriage 3/8-16 X 2 1/2
13	109-6886	1	Spring-Torsion	26	52-2860	1	Washer
14	109-8854	1	Pin-Chute	27	9266934	4	Screw-HWH 5/16 X 1/2 Tf
15	116-4670	1	Pulley-Idler, Flat	28	116-4669	1	Idler-Pulley, Flat
16	116-3455	1	Belt-B154.88	29	1-603299	3	Roller-Scalp, Anti
17	116-5138	3	ASM,Cutter Housing Complete	30	98-5975	3	Washer-Spring Disc 3/8
17:1	116-5137	1	ASM,Cutter Housing	31	99-2842	3	Spacer
				32	3290-357	3	Nut-Whizlock 3/8-16

● Requires installation of mulch kit for proper mulching. See your Exmark dealer for details.

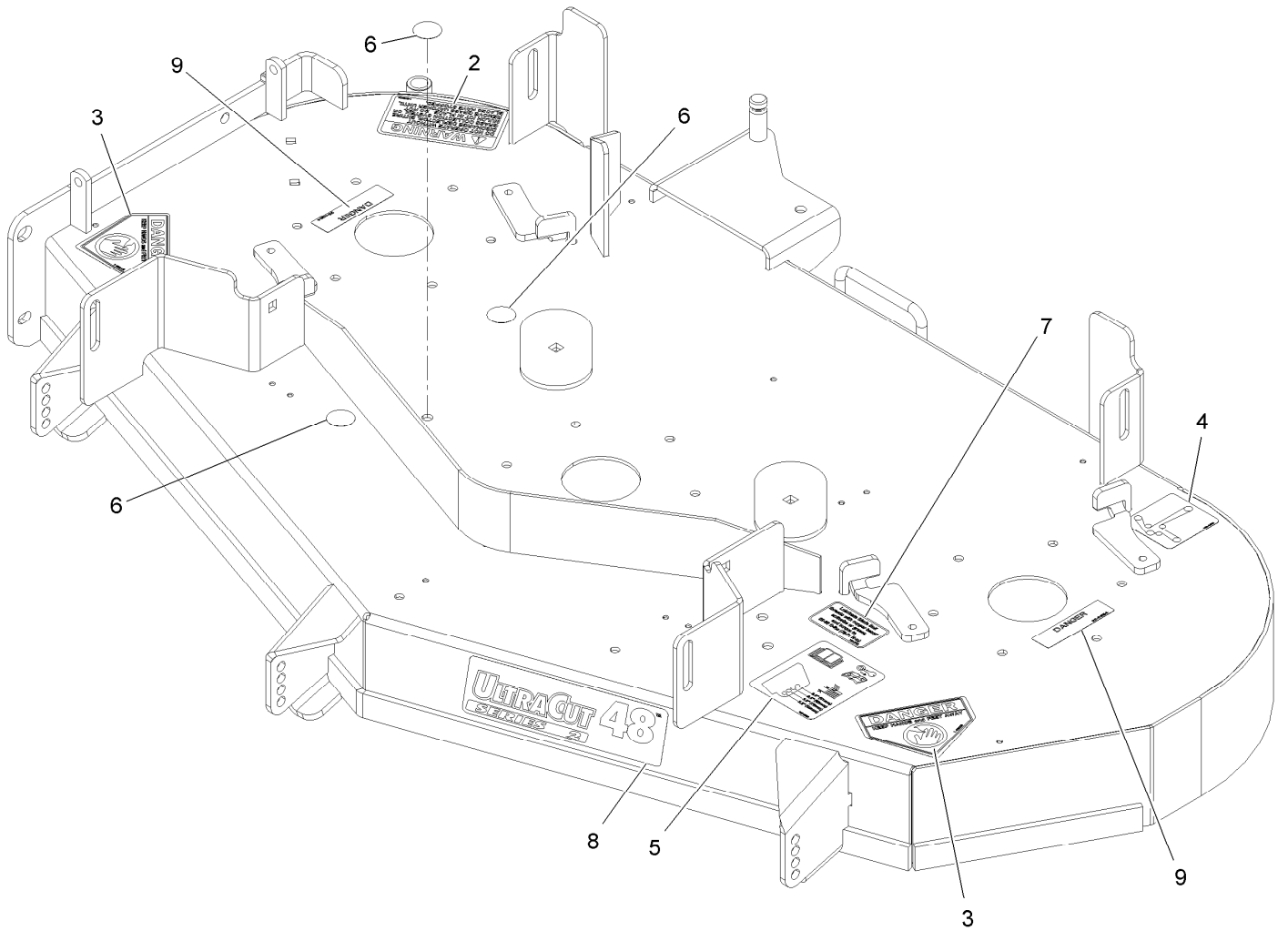

Deck W/Decals Assembly No. 116-5047

<i>Ref.</i>	<i>Part Number</i>	<i>Qty.</i>	<i>Description</i>
2	1-303508	1	Decal-Warning, Discharge
3	1-403005	2	Decal-Danger
4	109-6035	1	Decal-Belt Routing
5	109-6036	1	Decal-Roller, Anti-Scalp
6	109-9159	3	Decal-Hole Cover
7	109-3148	1	Decal,Bolt Torque
8	116-4696	1	Decal-Ultracut 48 Series 2
9	98-5954	2	Decal-Cover, Missing

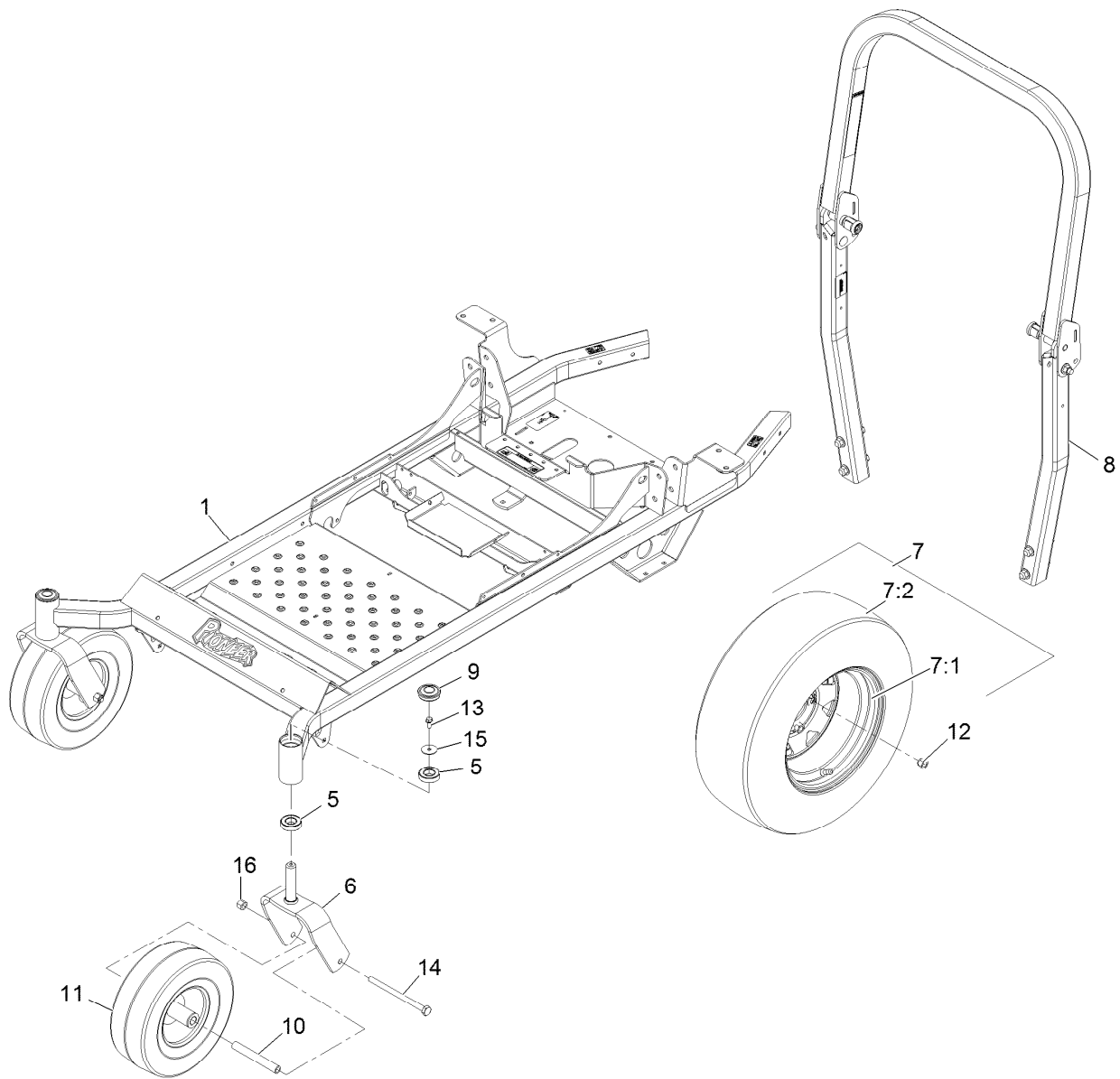

Mainframe Assembly

Ref.	Part Number	Qty.	Description
1	116-6831	1	Frame ASM-48-52
5	109-3678	4	Bearing-Ball
6	116-0611-01	2	Wld,Caster Fork
7	116-3163	2	Wheel And Tire ASM
7:1	116-2299	1	Wheel,10 X 6.00
7:2	116-3165	1	Tire
8	116-3498	1	ASM-ROPS Pioneer
9	116-4348	2	Cap-Grease
10	119-3475	2	Spanner
11	120-2251	2	ASM-Tire And Wheel, 13 In Smooth
12	242-50	8	Nut-Lug 1/2-20
13	3234-5	2	Screw-HH Flg 5/16-18 X 3/4
14	325-36	2	Screw-HH 1/2-13 X 7 1/2
15	3256-68	2	Washer-Flat
16	3296-23	2	Nut-Nyloc 1/2-13

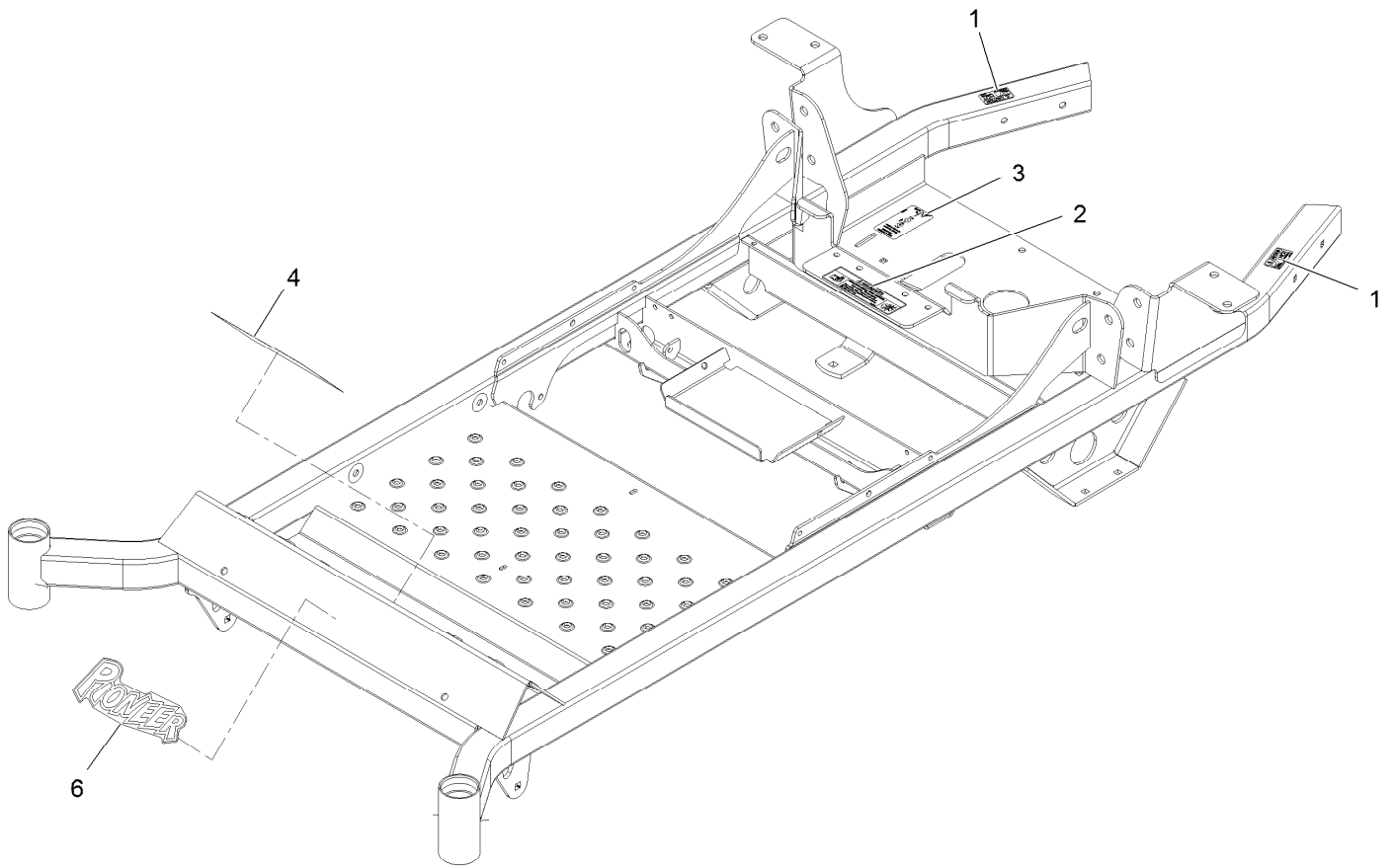

Mainframe W/Decals Assembly No. 116-6831

<i>Ref.</i>	<i>Part Number</i>	<i>Qty.</i>	<i>Description</i>
1	103-2076	2	Decal-Caution
2	116-1119	1	Decal,Belt Drive
3	116-6363	2	Decal-Drive Release
4	116-3303	1	Decal-Slope
6	116-4570	1	Decal-Pioneer Logo

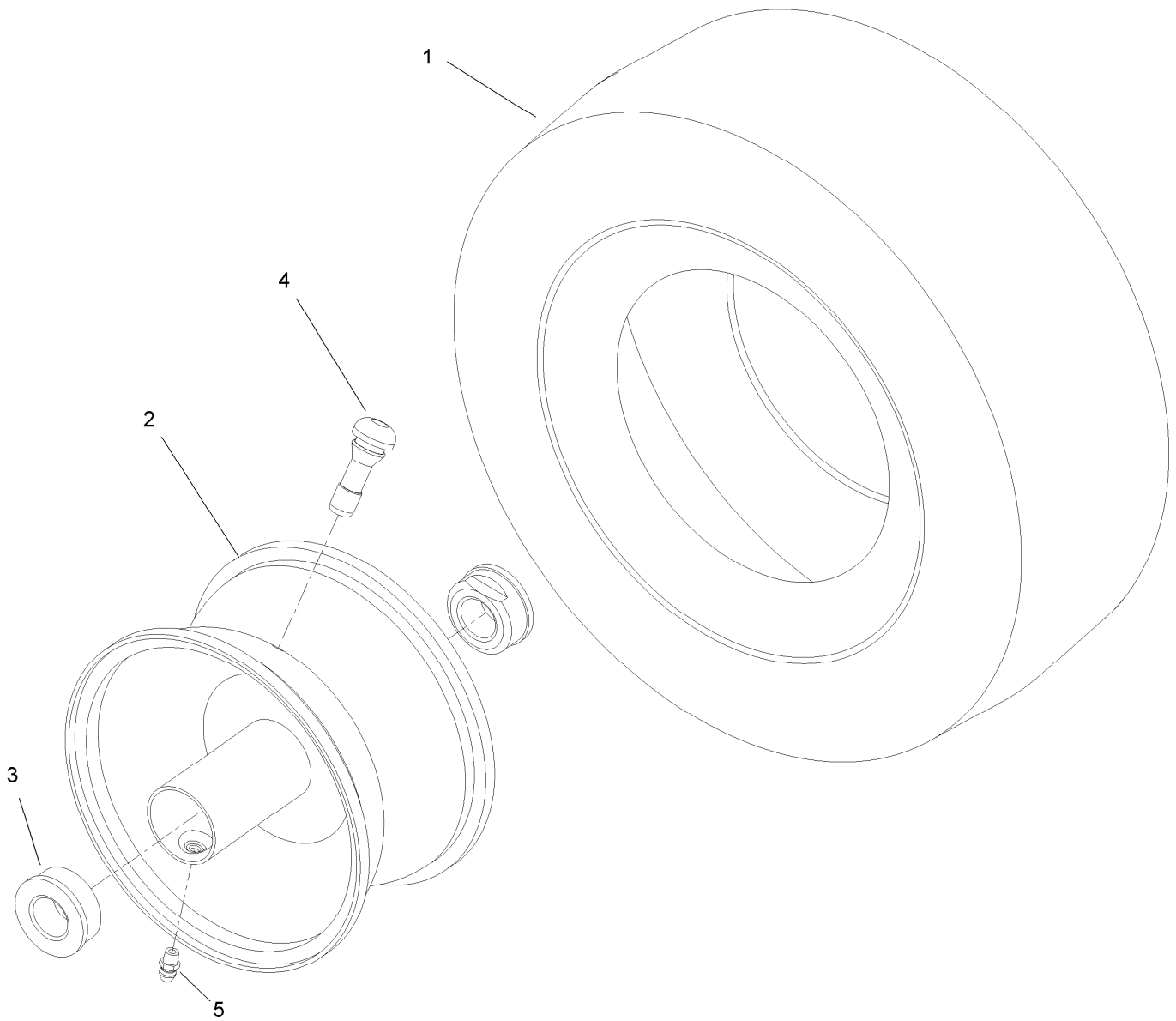

Caster Wheel Asembly No. 120-2251

<i>Ref.</i>	<i>Part Number</i>	<i>Qty.</i>	<i>Description</i>
1	120-2252	1	Tire-13 In Smooth
2	119-3472	1	Rim-6"
3	114-1640	2	Bushing-Flange
4	232-27	1	Stem-Valve
5	302-5	1	Zerk 1/4-28 Str Thrd Forming

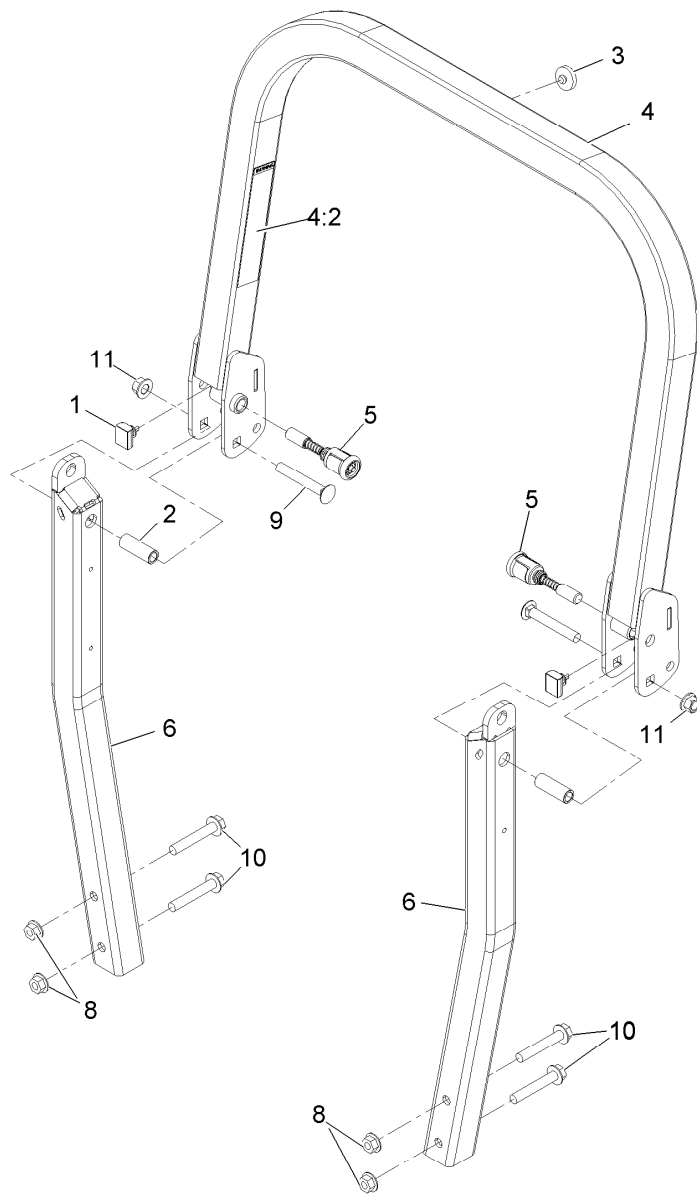

Roll-Over Protection System Assembly No. 116-3498

Ref.	Part Number	Qty.	Description
1	109-5337	2	Bumper-ROPS
2	109-6653	2	Spacer
3	109-9233	1	Bumper-Push-In, Rubber
4	116-0019	1	Upper ROPS ASM
4:2	107-2102	1	Decal-Warning, Folding ROPS
5	116-0104	2	Spring Pin ASM
6		2	ASM-Lwr ROPS Leg ●
8	32128-49	4	Nut-Whizlock 1/2-13
9	3233-10	2	Bolt-Carriage 1/2-13 X 3 1/2
10	3234-40	4	Screw-HF
11	99-5107	2	Nut-Lock 1/2-13

● Not serviced separately

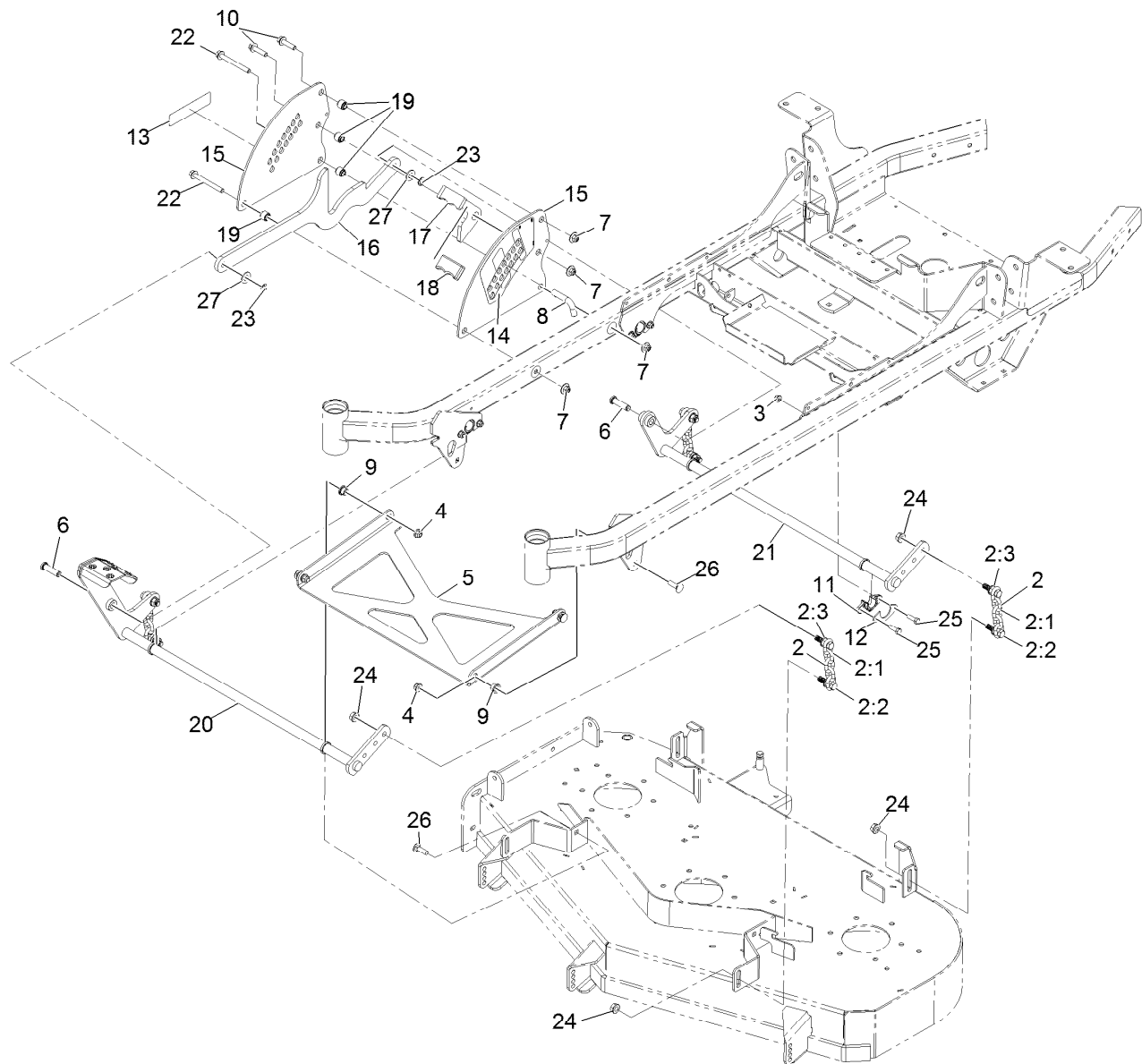

Deck Lift Assembly

<i>Ref.</i>	<i>Part Number</i>	<i>Qty.</i>	<i>Description</i>	<i>Ref.</i>	<i>Part Number</i>	<i>Qty.</i>	<i>Description</i>
2	103-9817	4	Deck Chain ASM	13	116-3885	1	Decal-E-Series
2:1	1-633447	1	Chain-Lift, Deck	14	116-4308	1	Decal-Height Of Cut
2:2	103-1898	2	Screw-HH 7/16-20 X 1-5/8 Sp	15	116-4309-03	2	Plate,Deck Lift
2:3	32128-37	2	Nut-Whizlock 7/16-14	16	116-4310-03	1	Link-HOC
3	104-8300	8	Nut-Nyloc 5/16-18 Flg	17	116-4311	1	Transport Lock-HOC
4	104-8301	4	Nut-Nyloc 3/8-16 Flg	18	116-4312	1	Grip-3/8 X 1 Flat Bar
5	109-3723-01	1	Strut-Deck	19	116-4313	4	Spacer-Double Step
6	109-5819	2	Pin-Clevis	20	116-6011-03	1	Wld-Deck Lift Shaft Frt
7	109-6658	4	Nut-Nyloc 3/8-16 Flg	21	116-6012-03	1	Wld-Deck Lift Shaft Rr
8	116-5584	1	Pin-HOC	22	116-4701	2	Screw-HHF
9	109-8788	4	Bushing-Flanged	23	32120-47	2	Ring-Retaining
10	114-4681	2	Screw-HHF	24	32128-37	8	Nut-Whizlock 7/16-14
11	115-5065	4	Bushing-Flange	25	322-5	8	Screw-HH 5/16-18 X 1
12	116-2887	4	Gusset-Deck Lift	26	3231-25	4	Bolt-Carriage 3/8-16 X 1 1/4
				27	3256-26	2	Washer-1/2 Sae

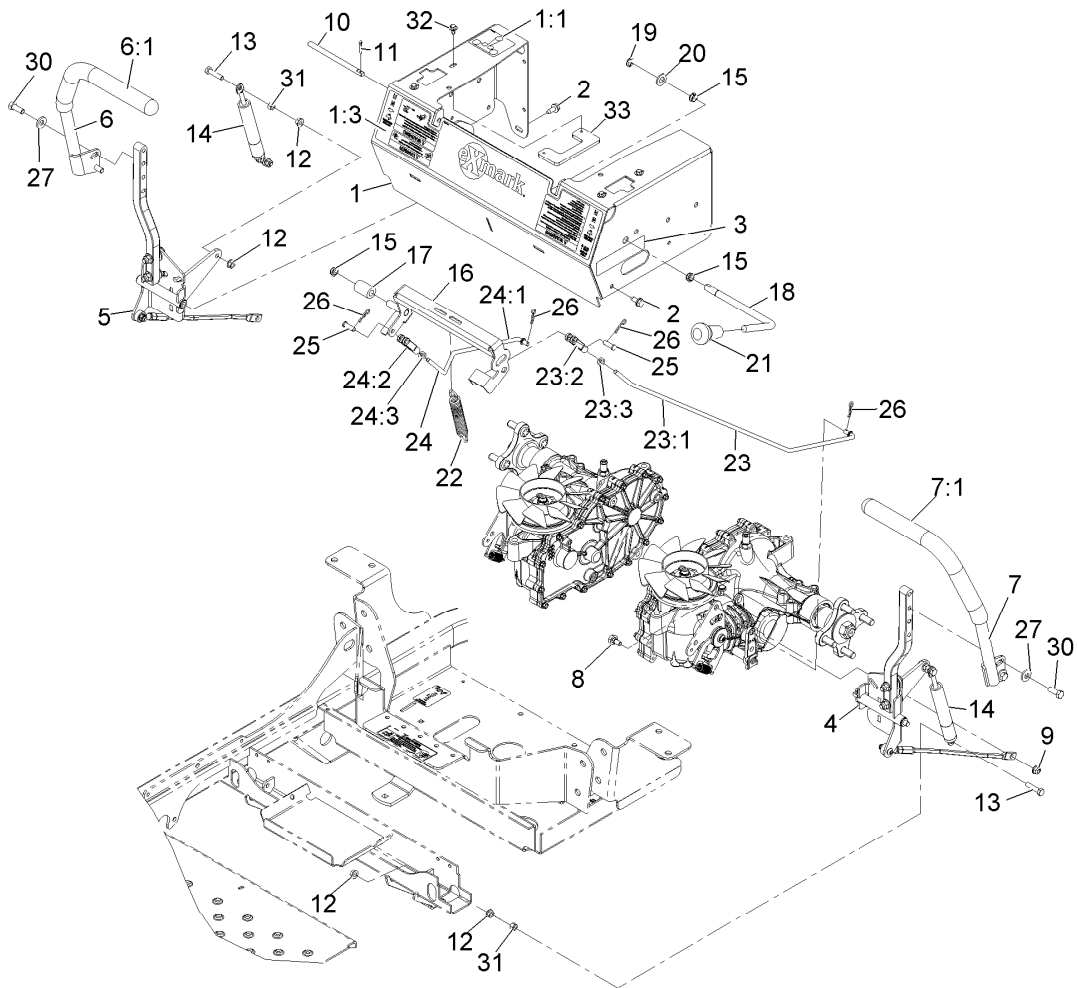

Motion Control Assembly

Ref.	Part Number	Qty.	Description	Ref.	Part Number	Qty.	Description
1	116-3188	1	ASM-Mot Ctrl Frm W/Dcl	16	116-6233	1	ASM-Brake Center Arm
1:1	109-6014	1	Decal-Belt Routing	17	109-5010	1	Spacer
1:3	116-4430	1	Decal-Front Panel	18	116-3155	1	Handle, Brake
2	32144-70	6	Screw-HWH 5/16-18 X 3/4 Tf	19	32120-47	1	Ring-Retaining
3	116-3885	1	Decal-E-Series	20	106-9888	1	Washer-Flat
4		1	Motion Control ASM-LH ●	21	106-7952	1	Knob
5		1	Motion Control ASM-RH ●	22	88-6130	1	Spring-Deck, Engagement
6	119-3486	1	RH Handle ASM	23	116-1165	1	Brake Linkage ASM-LH
6:1	108-6187	1	Grip	23:1	116-1167	1	Linkage, Brake LH
7	119-3485	1	LH Handle ASM	23:2	1-303105	1	Yoke-Adjustable
7:1	108-6187	1	Grip	23:3	3220-2	1	Nut-Jam 5/16-24
8	37-8771	2	Screw-Shoulder 5/16-18 X 5/8	24	116-1166	1	Brake Linkage ASM-RH
9	104-8300	2	Nut-Nyloc 5/16-18 Flg	24:1	116-1168	1	Linkage-Brake, RH
10	109-3705	2	Pin-Control Pivot	24:2	1-303105	1	Yoke-Adjustable
11	3272-10	2	Pin-Cotter 1/8 X 3/4	24:3	3220-2	1	Nut-Jam 5/16-24
12	32128-20	8	Nut-Whizlock 5/16-18	25	1-808280	2	Pin-Clevis 5/16 X 1 49/64
13	1-403180	4	Screw-HH 5/16-18 X 1 1/4 Sp	26	1-806003	4	Hairpin-Cotter
14	109-5957	2	Damper-Motion Control	27	98-5975	4	Washer-Spring Disc 3/8
15	116-1393	3	Bushing, Snap	30	323-6	4	Screw-HH 3/8-16 X 1
				31	3217-6	4	Nut-Hex 5/16-18
				32	46-8560	4	Screw-HHF 1/4-20 X 1/2
				33	109-6214	2	Stop-Motion Control

● Not serviced separately

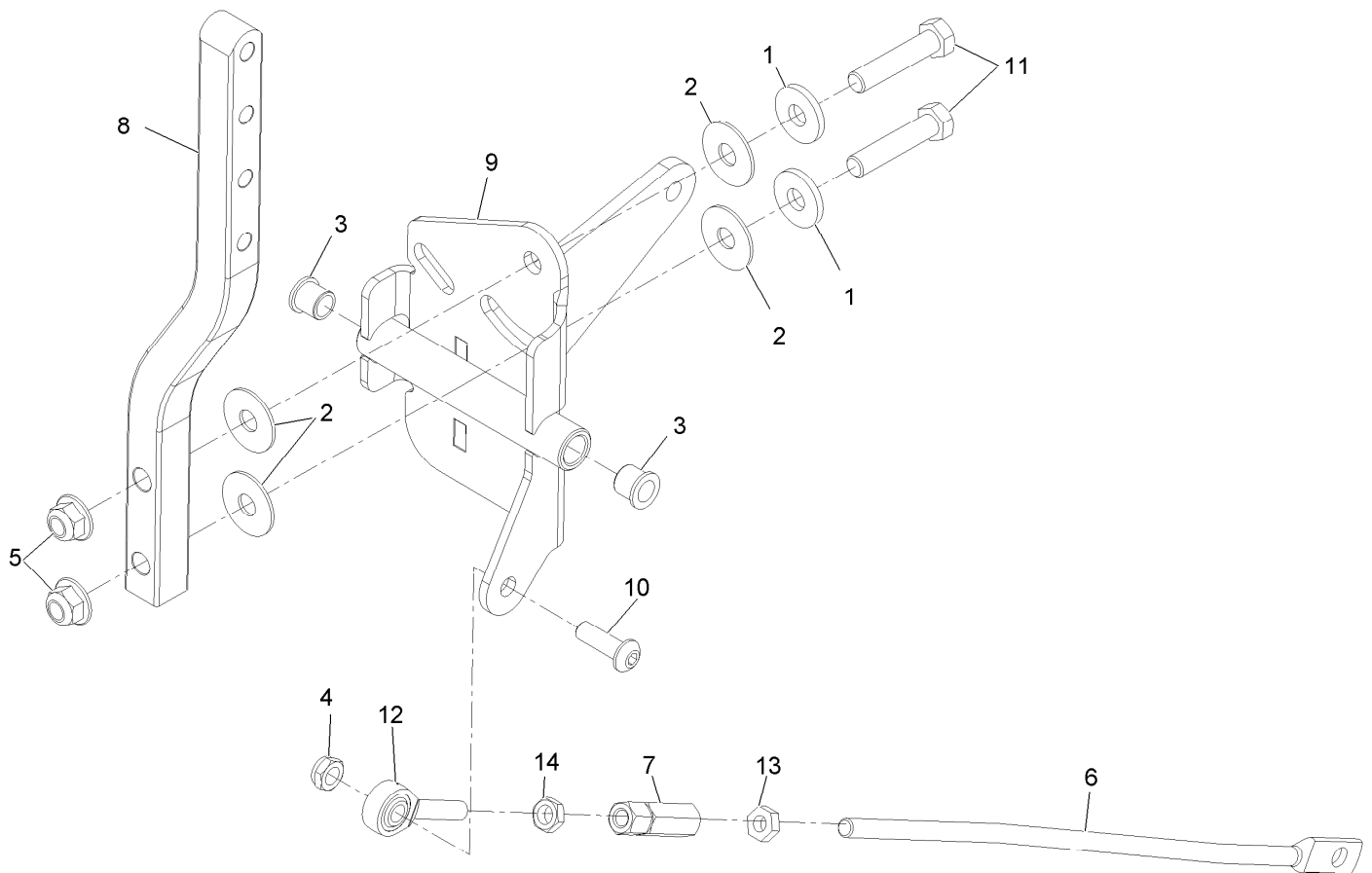

Motion Control Assembly - LH

Ref.	Part Number	Qty.	Description
1	5-0838	2	Washer
2	52-2900	4	Washer-Plastic
3	103-9928	2	Bearing
4	3296-47	1	Nut-Nyloc 5/16-18 Thin
5	104-8301	2	Nut-Nyloc 3/8-16 Flg
6	116-2543	1	Link,Motion Control
7	109-3728	1	Nut-Rod Adjustment
8	116-3183	1	Arm-Motion Control
9	116-3176	1	LH Control Pivot ASM
10	3274-104	1	Screw-Button Head 5/16-18 X 1
11	323-9	2	Screw-HH 3/8-16 X 1 3/4
12	2411-53	1	Balljoint LH
13	3220-2	1	Nut-Jam 5/16-24
14	3220-20	1	Nut-Jam 5/16-24 LH

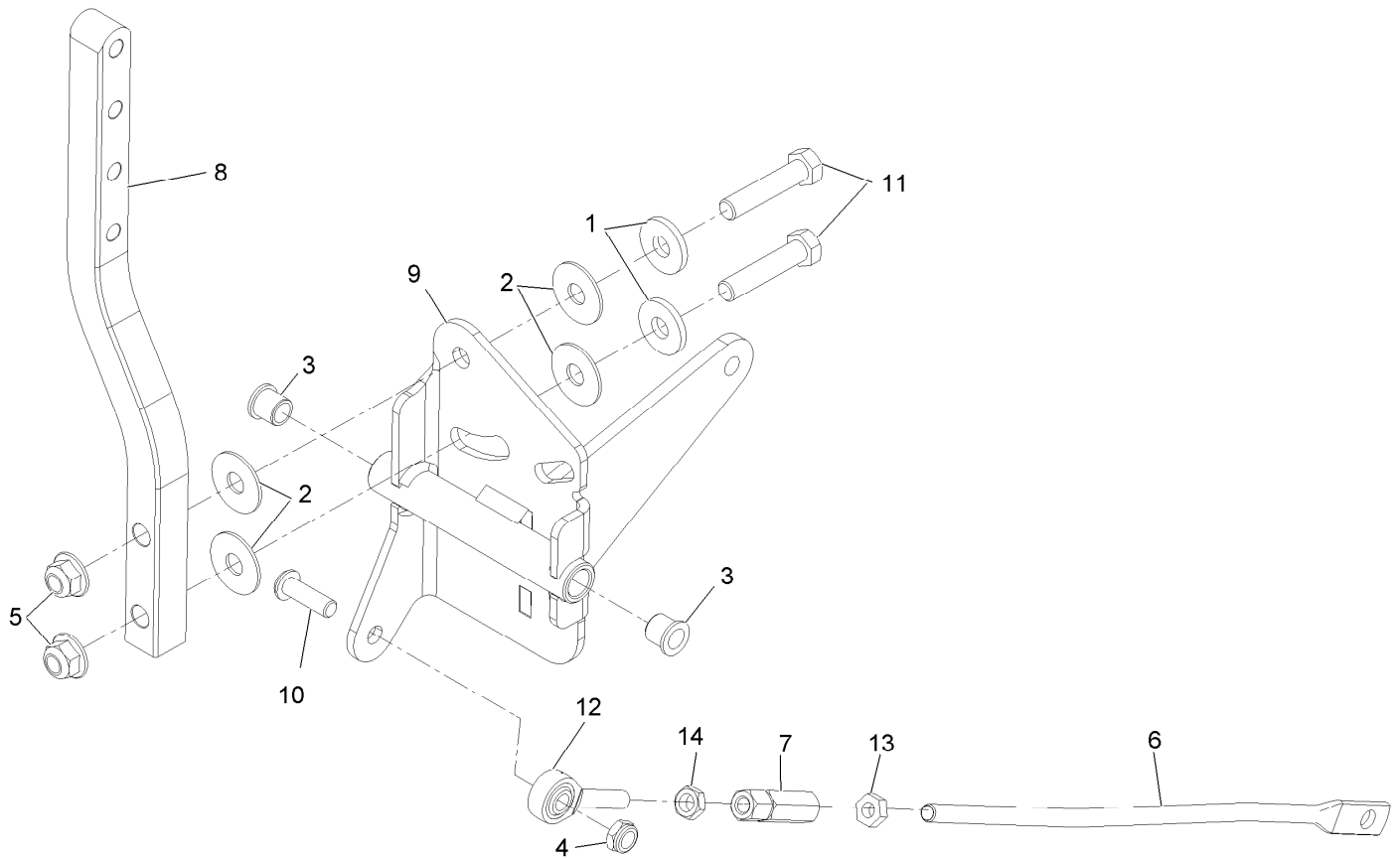

Motion Control Assembly - RH

<i>Ref.</i>	<i>Part Number</i>	<i>Qty.</i>	<i>Description</i>
1	5-0838	2	Washer
2	52-2900	4	Washer-Plastic
3	103-9928	2	Bearing
4	3296-47	1	Nut-Nyloc 5/16-18 Thin
5	104-8301	2	Nut-Nyloc 3/8-16 Flg
6	116-2543	1	Link, Motion Control
7	109-3728	1	Nut-Rod Adjustment
8	116-3183	1	Arm-Motion Control
9	116-3179	1	RH Control Pivot ASM
10	3274-104	1	Screw-Button Head 5/16-18 X 1
11	323-9	2	Screw-HH 3/8-16 X 1 3/4
12	2411-53	1	Balljoint LH
13	3220-2	1	Nut-Jam 5/16-24
14	3220-20	1	Nut-Jam 5/16-24 LH

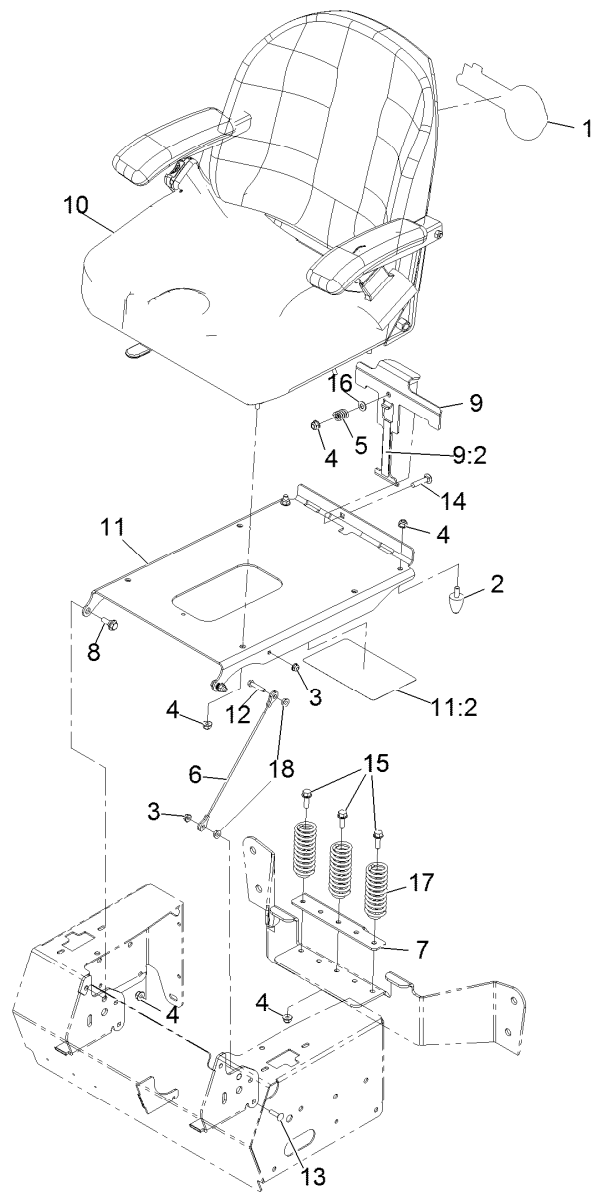

Seat Assembly

<i>Ref.</i>	<i>Part Number</i>	<i>Qty.</i>	<i>Description</i>	<i>Ref.</i>	<i>Part Number</i>	<i>Qty.</i>	<i>Description</i>
1	103-2882	1	Decal,Exmark Logo	11	116-4418	1	Plate, Seat W/Decals
2	103-9376	2	Bumper-Seat	11:2	109-6016	1	Decal-Service Aid
3	104-7201	2	Nut-Nyloc 1/4-20 Flg	12	321-8	1	Screw-HH 1/4-20 X 1 1/4
4	104-8300	12	Nut-Nyloc 5/16-18 Flg	13	3229-2	1	Bolt-Carriage 1/4-20 X 1
5	107-3017	1	Spring-Compression	14	3230-4	1	Bolt-Carriage 5/16-18 X 1 1/2
6	109-2628	1	Cable-Stop, Seat	15	3234-29	3	Screw-HH Flg 5/16-18 X 1
7	116-0871	1	Catch,Seat Latch	16	3256-23	1	Washer-5/16 Sae
8	116-1297	2	Screw-Shoulder	17	92-7054	3	Spring-Compression
9	116-3121	1	ASM-Seat Latch	18	32128-33	2	Nut-Whizlock 1/4-20
9:2	116-3120	1	Strip-Poly Wear				
10	116-6192	1	Asm-Seat Service				

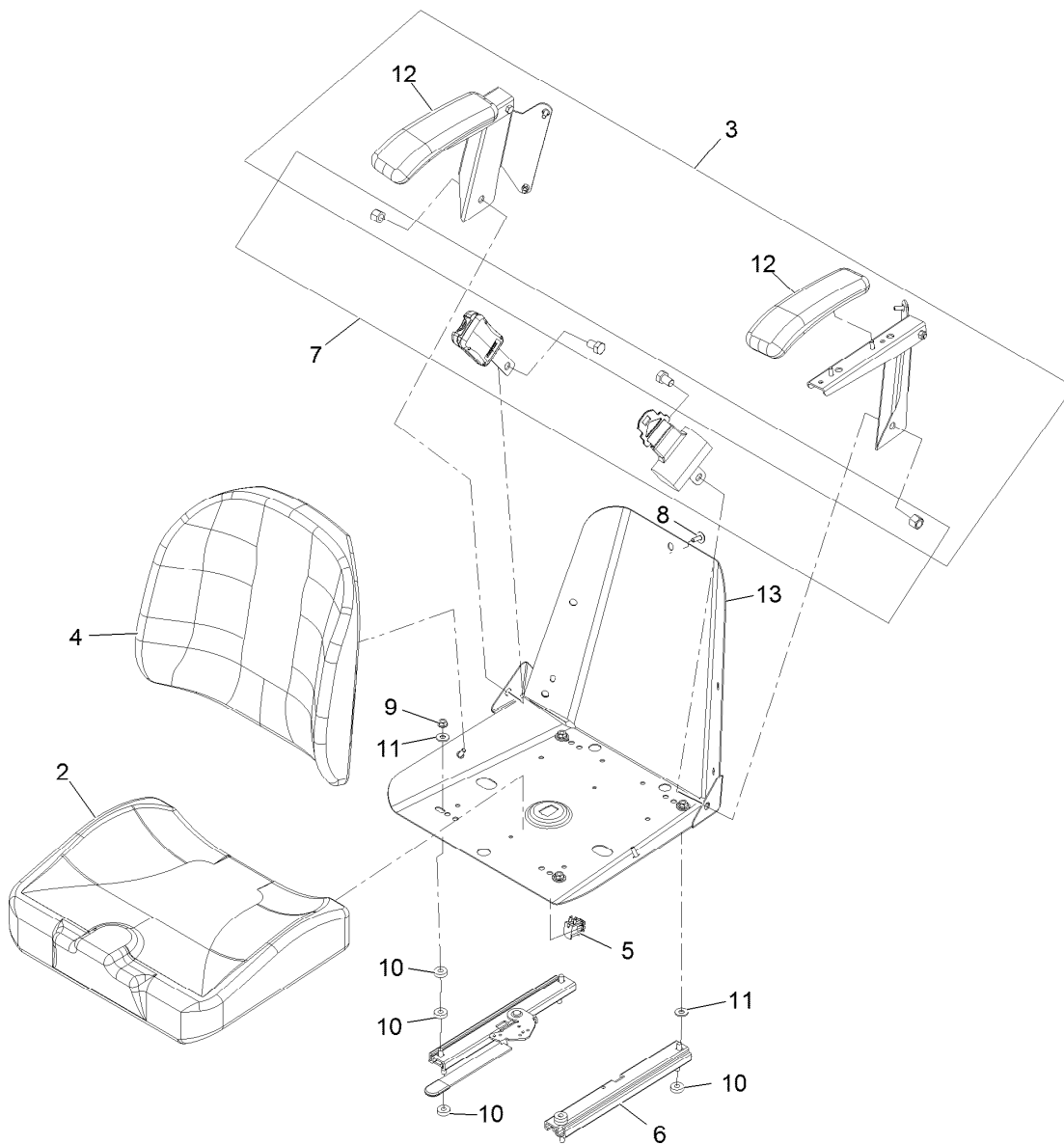

Seat W/Tracks Assembly No. 116-6192

Ref.	Part Number	Qty.	Description
2	116-7329	1	Cushion-Seat Bottom
3	110-5719	1	Armrest Kit
4	116-3738	1	Cushion,Seat Back
5	82-2190	1	Switch
6	1-643255	1	Track-Seat
7	116-2981	1	Seat Belt Kit
8	103-8383	7	Screw-HWH 1/4-20 X 3/4 Taptite
9	32128-20	4	Nut-Whizlock 5/16-18
10	26-4840	8	Spacer-Pin, Mounting
11	3256-3	6	Washer-5/16 Std
12	110-4163	2	Cushion-Rest, Arm
13	116-7496	1	Frame-Seat

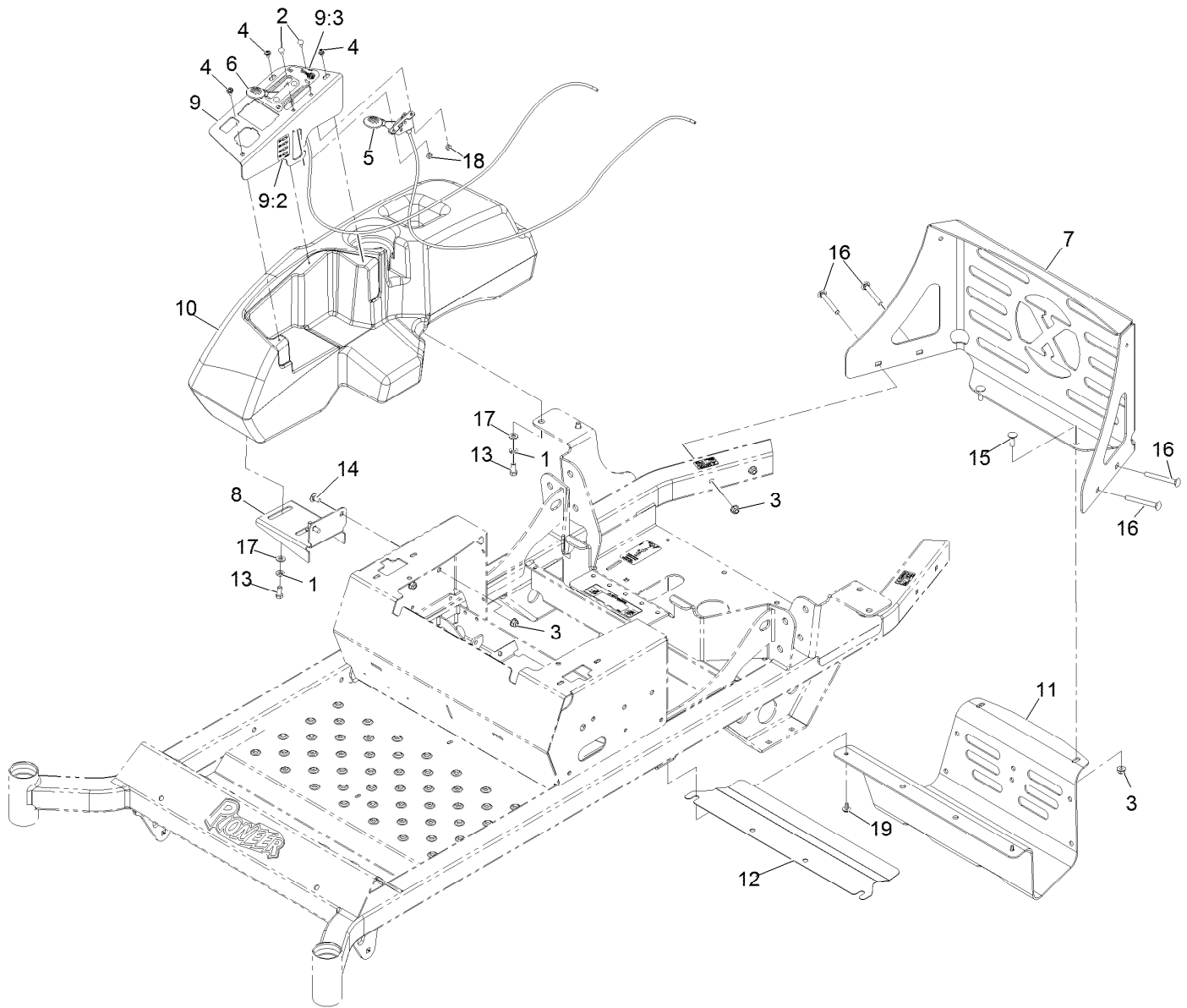

Controls Assembly

Ref.	Part Number	Qty.	Description	Ref.	Part Number	Qty.	Description
1	1-805005	4	Washer-Lock 5/16 Heavy	10	116-4138	1	Console,RH
2	1-807513	4	Bolt-Carriage #10-24 X 1/2	11	116-4708-03	1	Guard-Muffler
3	104-8300	8	Nut-Nyloc 5/16-18 Flg	12	116-6004-03	1	Shield-Heat Deflector
4	109-2661	3	Screw-PPH #10-24 X 1/2	13	322-3	4	Screw-HH 5/16-18 X 3/4
5	116-4919	1	Control,Throttle	14	3230-18	2	Bolt-Carriage 5/16-18 X 5/8
6	109-8747	1	Control,Choke	15	3230-2	2	Bolt-Carriage 5/16-18 X 1
7	116-3453-03	1	Panel,Rear Guard	16	3230-9	4	Bolt-Carriage 5/16-18 X 2 3/4
8	116-3495-03	1	Bracket-Tank And Fender	17	3256-23	4	Washer-5/16 Sae
9	116-3496	1	ASM,Control Panel W/Decal	18	3296-2	4	Nut-Nyloc #10-24
9:2	116-1496	1	Decal,Fuse Block	19	46-8560	2	Screw-HHF 1/4-20 X 1/2
9:3	116-4465	1	Decal-Throttle Choke				

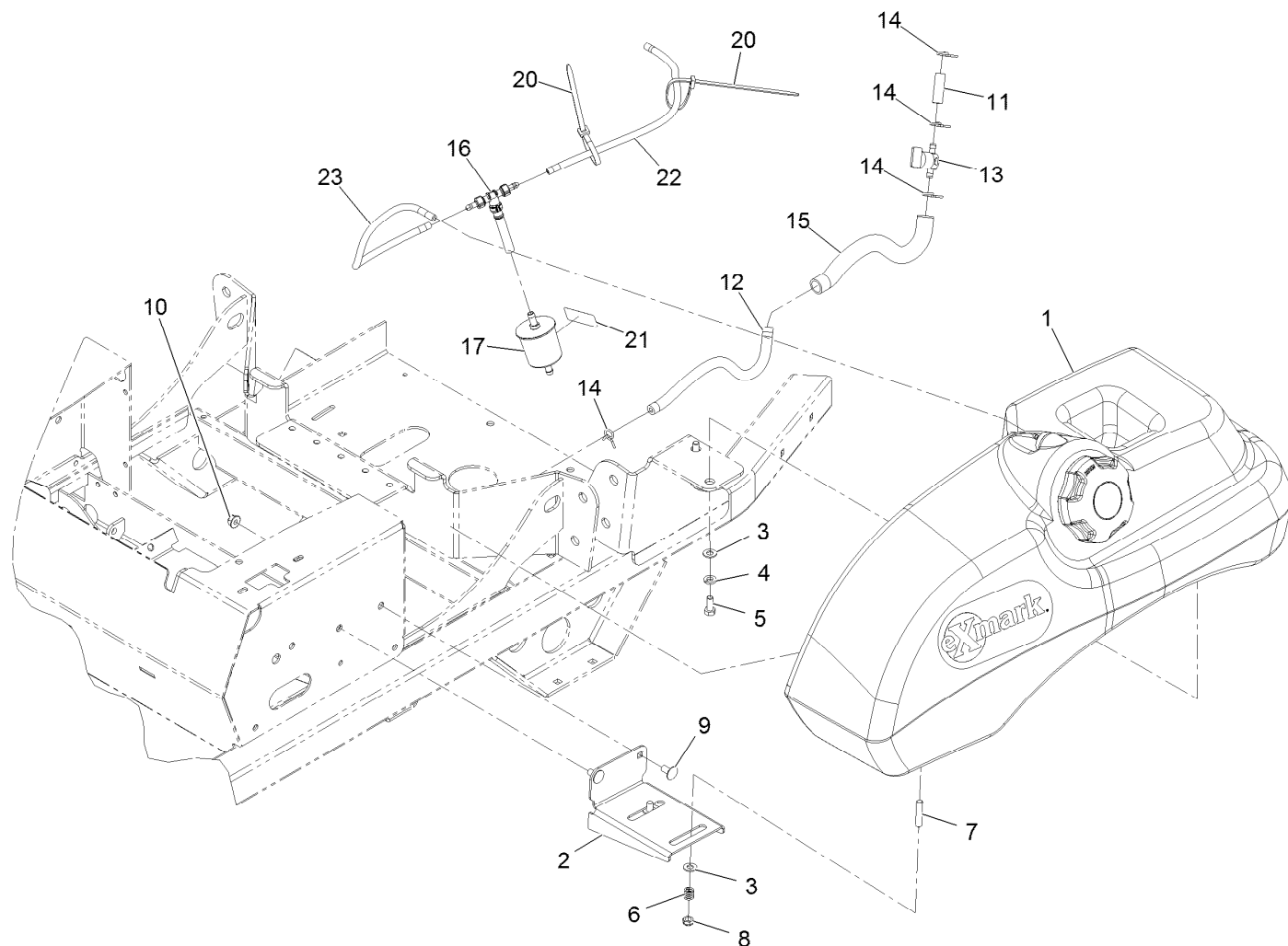

Fuel Tank Assembly

Ref.	Part Number	Qty.	Description	Ref.	Part Number	Qty.	Description
1	116-4610	1	ASM-Fuel Tank	12	109-0282	1	Hose-Fuel
2	116-3495-03	1	Bracket-Tank And Fender	13	1-603770	1	Valve-Fuel
3	3256-23	4	Washer-5/16 Sae	14	1-303077	4	Clamp-Fuel Line
4	1-805005	2	Washer-Lock 5/16 Heavy	15	116-4515	1	Conduit-Fuel Line
5	322-3	2	Screw-HH 5/16-18 X 3/4	16	116-5464	1	Tee And Check ASM
6	1-633349	2	Spring-Compression	17	120-2235	1	Filter-Air
7	1-633023	2	Stud-Fuel Tank ●	20	1-303335	2	Tie-Cable 7 15/16 (Large)
8	3296-47	2	Nut-Nyloc 5/16-18 Thin	21	116-4769	1	Decal-Filter, Emissions
9	3230-18	2	Bolt-Carriage 5/16-18 X 5/8	22	116-4800	1	Hose,Emissions
10	104-8300	2	Nut-Nyloc 5/16-18 Flg	23	116-4801	1	Hose,Emissions
11	106-9492	1	Hose-Fuel				

● Use Pro-Lock, Nut Type (P/N 1-840022, .5ml tube) on threads.

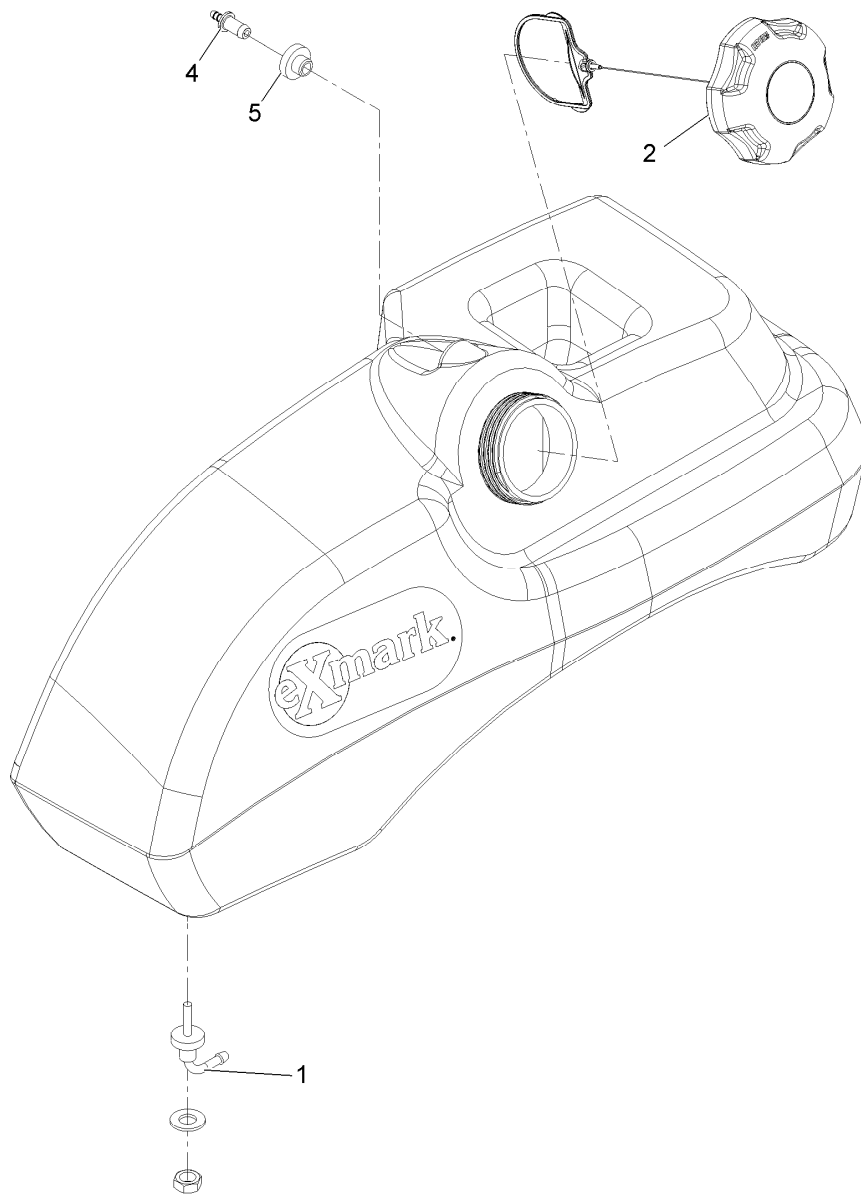

Fuel Tank Assembly No. 116-4610

<i>Ref.</i>	<i>Part Number</i>	<i>Qty.</i>	<i>Description</i>
1	103-2605	1	Fitting-Fuel Bulkhead W/Strainer ●
2	120-5461	1	Cap-Fuel, Ratcheting
4	116-4630	1	Fitting-Straight Orifice
5	46-6560	1	Bushing

● Use Pro-Lock, Nut Type (P/N 1-840022, .5ml tube) on threads.

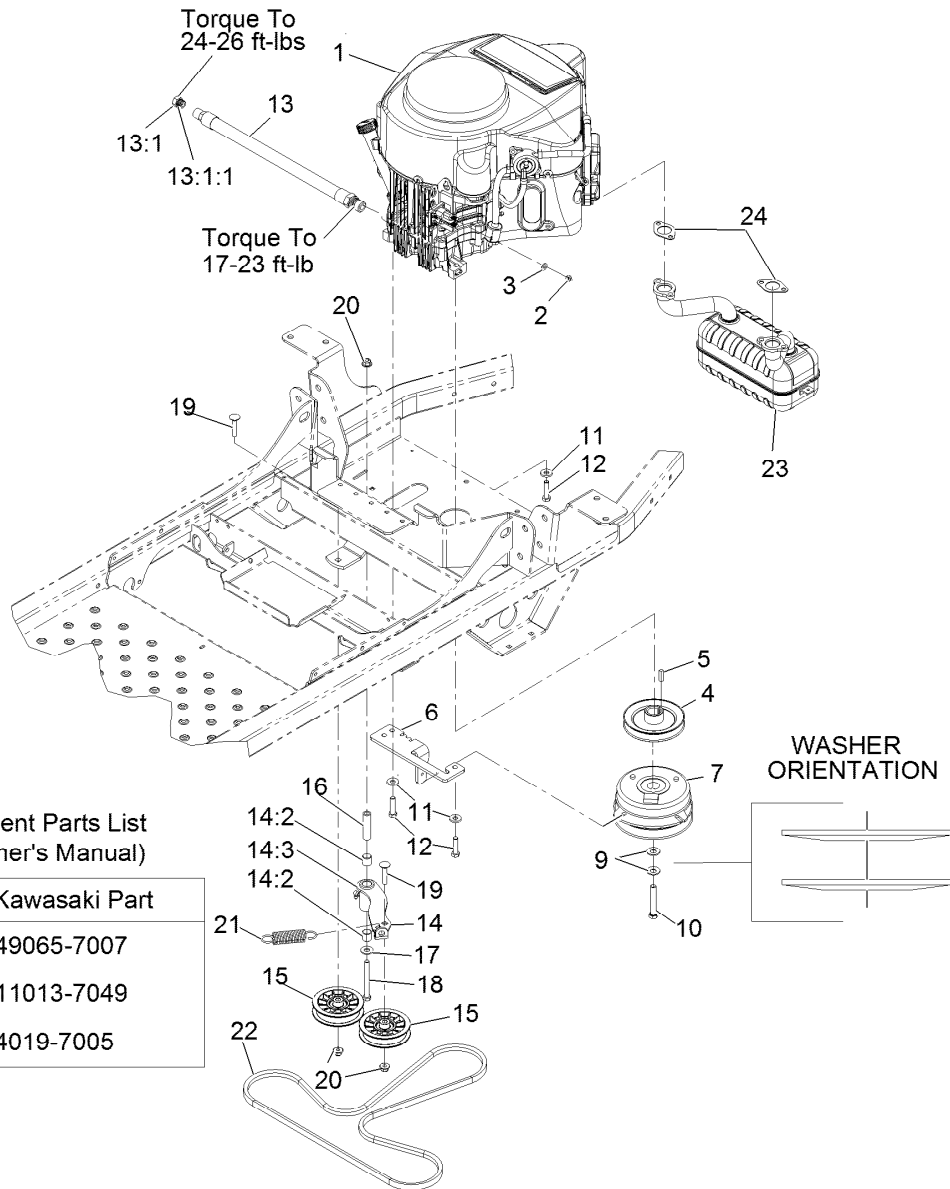

Kawasaki Replacement Parts List
(Refer To Engine Owner's Manual)

Description	Kawasaki Part
Engine Oil Filter	49065-7007
Engine Air Filter	11013-7049
Fuel Filter	4019-7005

Engine Assembly

Ref.	Part Number	Qty.	Description
1		1	Engine-Kawasaki ●■
2	3217-5	1	Nut-Hex 1/4-20
3	3256-22	1	Washer-1/4 Sae
4	109-3386	1	Sheave-Split Steel
5	1-807259	1	Key-Machine 1/4 X 1/4 X 1
6	116-4773-03	1	Anchor-Clutch
7	116-5059	1	Clutch, 125Ftlb 1.0 B
9	1-603610	2	Washer-Spring Disc 7/16
10	116-1066	1	Screw-HH 7/16-20 X 2 3/4 W/Loctite ◆
11	98-5975	4	Washer-Spring Disc 3/8
12	323-8	4	Screw-HH 3/8-16 X 1 1/2
13	116-4924	1	Asm-Hose Oil Drain W/Plug ▲
13:1	353-508	1	Plug-W/O-Ring

Ref.	Part Number	Qty.	Description
13:1:1	237-42	1	O-Ring
14	116-4729	1	ASM-Idler Arm W/Bearings
14:2	1-513034	2	Sleeve-Bearing
14:3	302-40	1	Zerk-90° 1/4-28
15	116-2456	2	Pulley-Flat, 3.50 Dia
16	1-603384	1	Bushing-Pivot, Idler
17	3256-4	1	Washer-3/8 Std
18	323-15	1	Screw-HH 3/8-16 X 3 1/2
19	3231-5	2	Bolt-Carriage 3/8-16 X 1 3/4
20	104-8301	3	Nut-Nyloc 3/8-16 Flg
21	1-603402	1	Spring-Extension
22	115-9613	1	V-Belt
23	117-7256	1	Muffler-Kawasaki
24	1-653313	2	Gasket-Exhaust

● Not serviced separately

▲ Use a Teflon Pipe Sealant or equivalent on threads.

◆ Use Pro-Lock, Nut Type (P/N 1-840022, .5ml tube) on threads.

■ Obtain parts from www.kawpowerepc.com

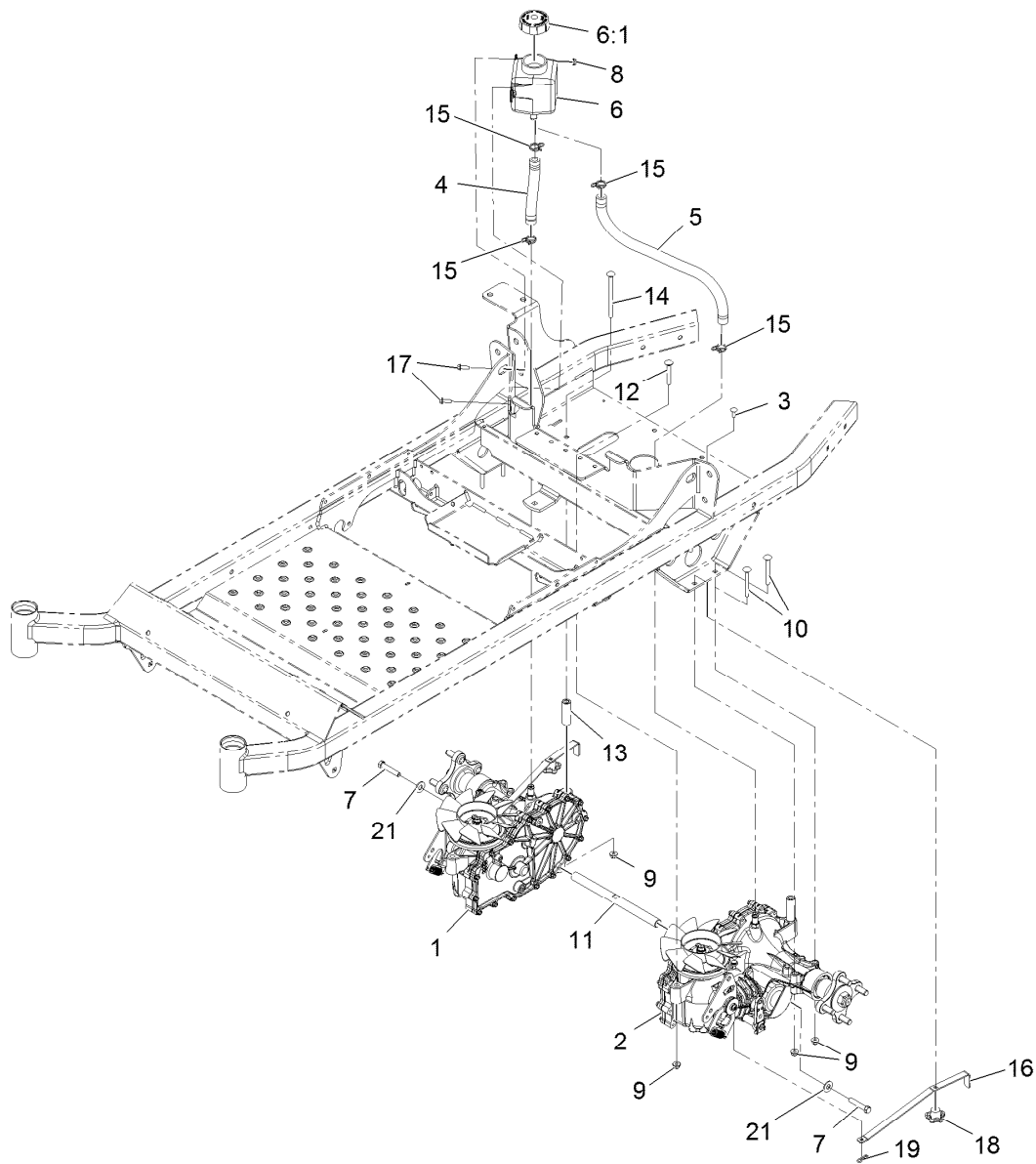

Hydraulic Assembly

Ref.	Part Number	Qty.	Description	Ref.	Part Number	Qty.	Description
1	116-4544	1	Transaxle ASM	11	116-6833	1	Shaft-Spacer
2	116-4545	1	Transaxle ASM	12	3230-7	2	Bolt-Carriage 5/16-18 X 2 1/4
3	3229-1	2	Bolt-Carriage 1/4-20 X 3/4	13	116-5809	2	Spacer-Hydro
4	116-5641	1	Hose-Hydraulic	14	3230-30	2	Bolt-Carriage 5/16-18 X 4 1/2
5	116-5642	1	Hose-Hydraulic	15	117-1193	4	Clamp-Hose
6	109-2250	1	Vent-Tank, Hydro	16	109-5395	2	Arm-Hydro Bypass
6:1	109-3320	1	Cap-Reservoir, HYD	17	32105-15	2	Screw-Machine 1/4-20 X 3/4
7	94-7972	2	Screw-HH W/Loctite ●	18	108-6402	2	Knob-Handle
8	104-7201	2	Nut-Nyloc 1/4-20 Flg	19	1-806003	2	Hairpin-Cotter
9	104-8300	8	Nut-Nyloc 5/16-18 Flg	21	3256-4	2	Washer-3/8 Std
10	3230-9	4	Bolt-Carriage 5/16-18 X 2 3/4				

● Use Pro-Lock, Nut Type (P/N 1-840022, .5ml tube) on threads.

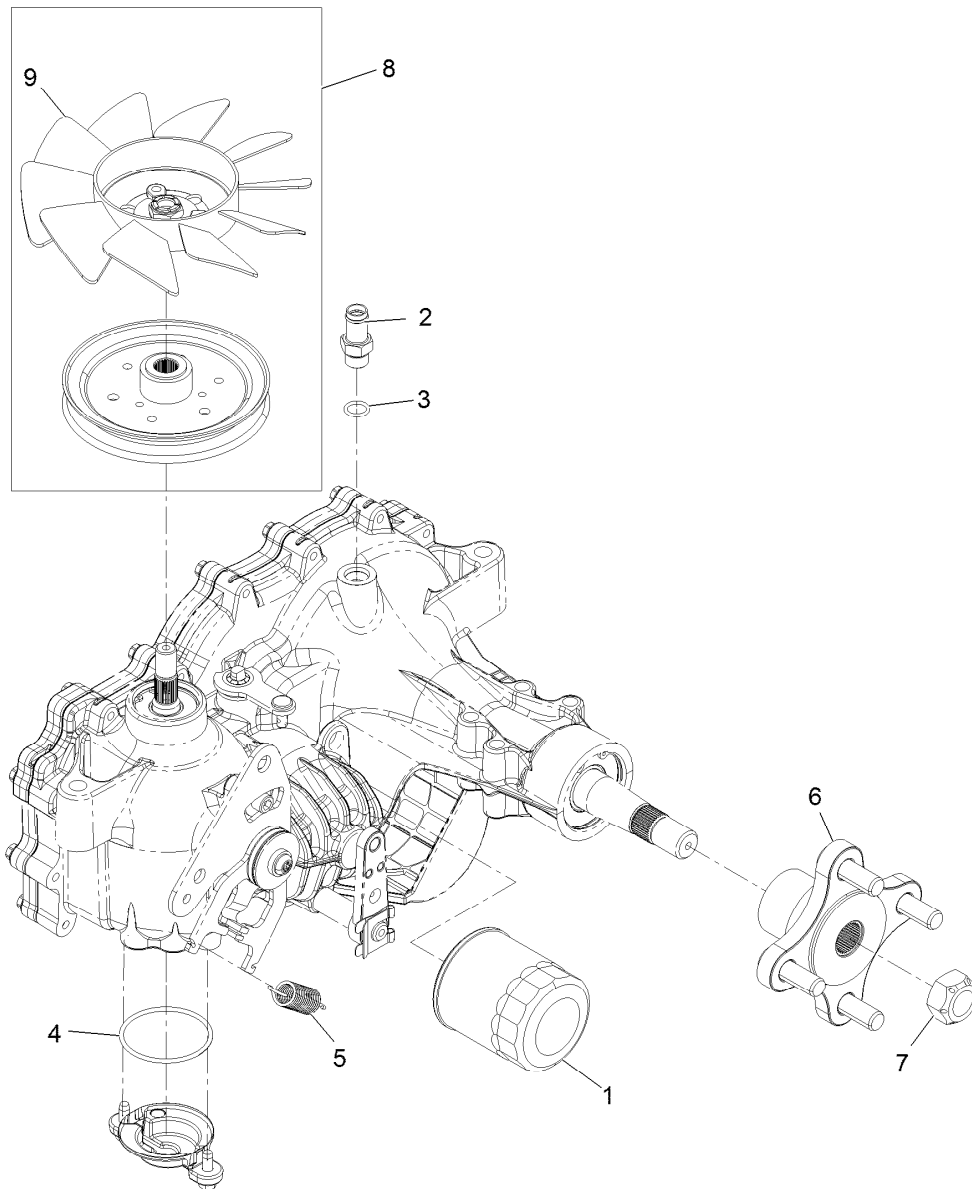

Transaxle Assembly

Ref.	Part Number	Qty.	Description
1	109-3321	1	Element-Oil Filter, HYD
2	109-3278	1	Adapter-Straight
3	237-42	1	O-Ring
4	109-3540	1	O-Ring-Seal
5	109-5592	1	Spring-Extension
6	109-5939	1	Hub Kit
7	109-3536	1	Nut-Hub
8	109-5938	1	Fan And Pulley Kit
9	114-8453	1	Fan-7.0
99	109-3537	1	Complete Seal Kit ●

● Not illustrated

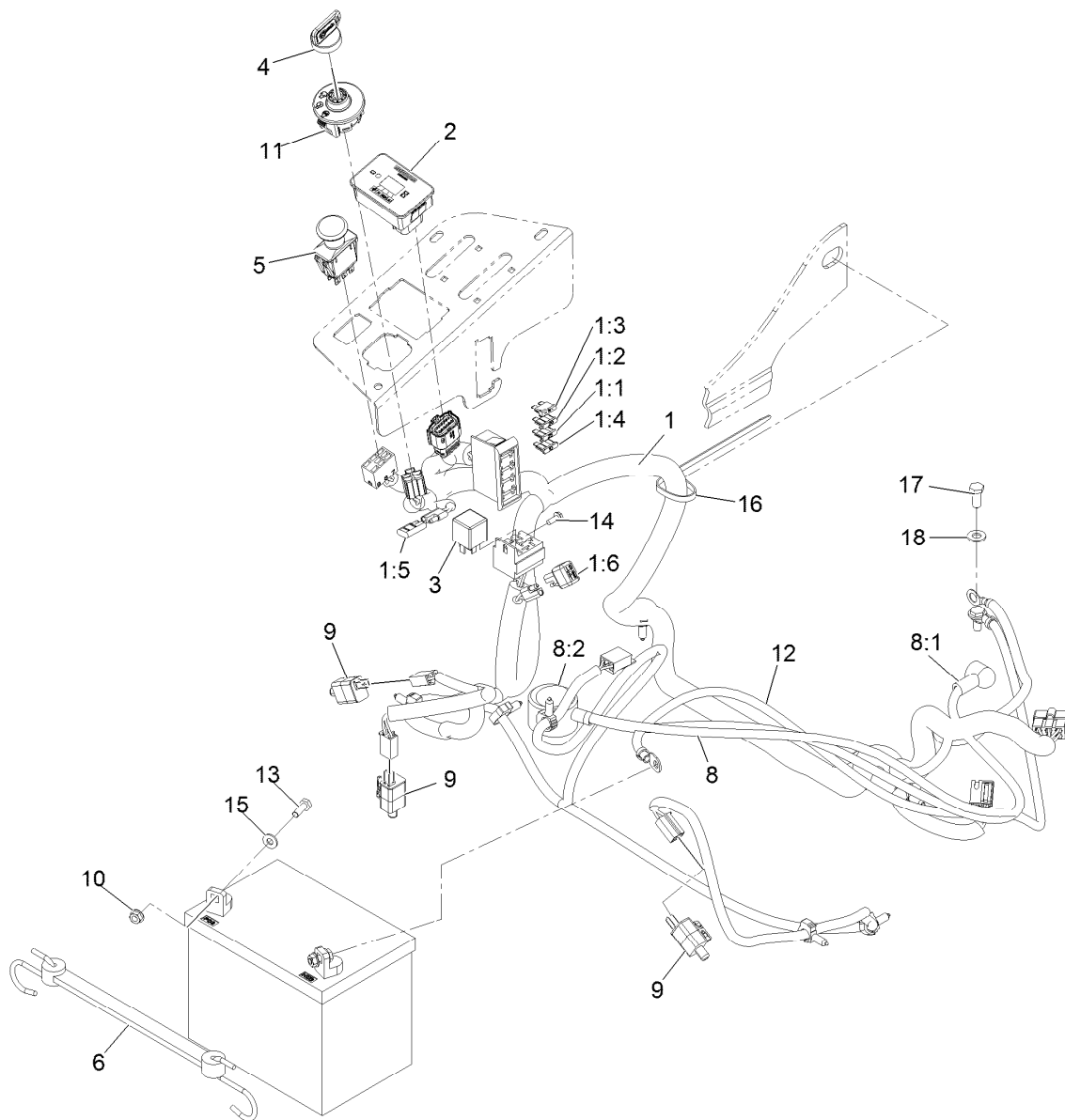

Electrical Assembly

Ref.	Part Number	Qty.	Description
1	116-4861	1	Harness, Wire ●
1:1	109102	1	Fuse-Blade, 25 Amp
1:2	1-816001	1	Fuse-Blade Type, 20 Amp
1:3	109355	1	Fuse-Blade, 15 Amp
1:4	218-578	1	Fuse-Blade, 10 Amp
1:5	116-0053	1	Cap-Plug
1:6	103-3895	1	Diode-Tvs
2	116-5609	1	Module ASM
3	1-643275	1	Relay-12Vdc 40 Amp
4	103-2106	1	Key-Exmark Logo
5	103-5221	1	Switch-PTO
6	104-2466	1	Holddown-Battery
8	109-7621	1	Positive Battery Cable ASM

Ref.	Part Number	Qty.	Description
8:1	1-543393	1	Insulator-Solenoid
8:2	109-2407	1	Insulator-Battery
9	110-6765	3	Switch-Single Pole No
10	32128-33	2	Nut-Whizlock 1/4-20
11	117-2221	1	Switch-Ignition
12	117-7240	1	Cable-Battery, Negative
13	321-4	2	Screw-HH 1/4-20 X 3/4
14	32144-1	1	Screw-HWH #10-24 X 1/2 Taptite
15	3256-22	2	Washer-1/4 Sae
16	1-303335	1	Tie-Cable 7 15/16 (Large)
17	33114-020	1	Screw-HH M8-1.25 X 20Mm
18	33094-00	1	Washer

● Use dielectric grease on all unsealed connectors and terminals only. Do not apply in sealed connectors.

Notes:

Notes:

Notes:

EXMARK® MAINTENANCE

MAXIMIZE THE PERFORMANCE OF YOUR EXMARK.

4-CYCLE PREMIUM ENGINE OIL

Part No. 116-3373

Both SAE 30 and SAE 10W-30 in one bottle.

Contains increased levels of zinc and phosphorus for better lubricity.

No Viscosity Index Improvers that tend to shear down in high heat.

Synthetic formulation.

Gas & Diesel compatible.

Anti-corrosion additives.

API 'SL' and JASO rated with wet clutch compatibility for other machines.

PREMIUM HYDRO OIL

Part No. 109-9828

Commercial quality for tough, high-heat conditions.

Designed specifically for zero-turn mower hydraulic systems.

Superior shear resistance under heavy loads.

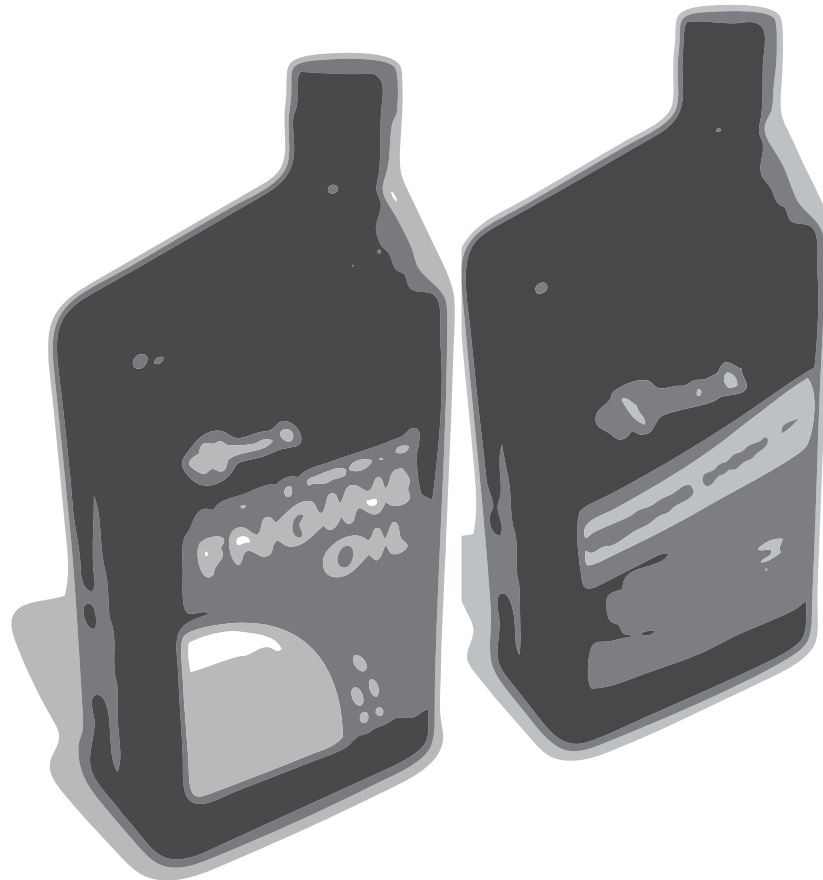

Available from your local Exmark dealer. Find your closest dealer at exmark.com

EXMARK ACCESSORIES AND OPTIONS*

MID-MOUNT RIDING ACCESSORIES AND OPTIONS

CUSTOM RIDE SEAT SUSPENSION SYSTEM	OPERATOR CONTROLLED DISCHARGE
FULL SUSPENSION SEAT	SUN SHADE
DECK LIFT ASSIST KIT	TRASH CONTAINER
HITCH KIT	TURF STRIPER
LIGHT KIT	ULTRA VAC COLLECTION SYSTEM
12V POWER PORT	ULTRA VAC QUICK DISPOSAL SYSTEM
MICRO-MULCH SYSTEM	

OUT-FRONT RIDING ACCESSORIES AND OPTIONS

CUSTOM RIDE SEAT SUSPENSION SYSTEM	SNOW BLADE
DUAL-TAIL WHEEL	SNOWBLOWER
FLOOR PAN EXTENDER	SUN SHADE
HITCH KIT	TRASH CONTAINER
LIGHT KIT	ULTRA VAC COLLECTION SYSTEM
MICRO-MULCH SYSTEM	ULTRA VAC QUICK DISPOSAL SYSTEM
ROLL OVER PROTECTION SYSTEM (ROPS)	WEATHER CAB

WALK-BEHIND ACCESSORIES AND OPTIONS

GRASS CATCHER	TURF STRIPER
MICRO-MULCH SYSTEM	STANDON

*Some accessories and options not available for some models.

Place Model No. and Serial No.
Label Here (Included in the Literature
Pack) or Fill in Below

Model No. _____

Serial No. _____

Date Purchased _____

Engine Model No. and Spec. No. _____

Engine Serial No. (E/No) _____

© 2012 Exmark Mfg. Co., Inc.
Industrial Park Box 808
Beatrice, NE 68310
All Rights Reserved

Part No. 4500-998 Rev. B
(402) 223-6300
Fax (402) 223-5489
Printed in the USA.

