

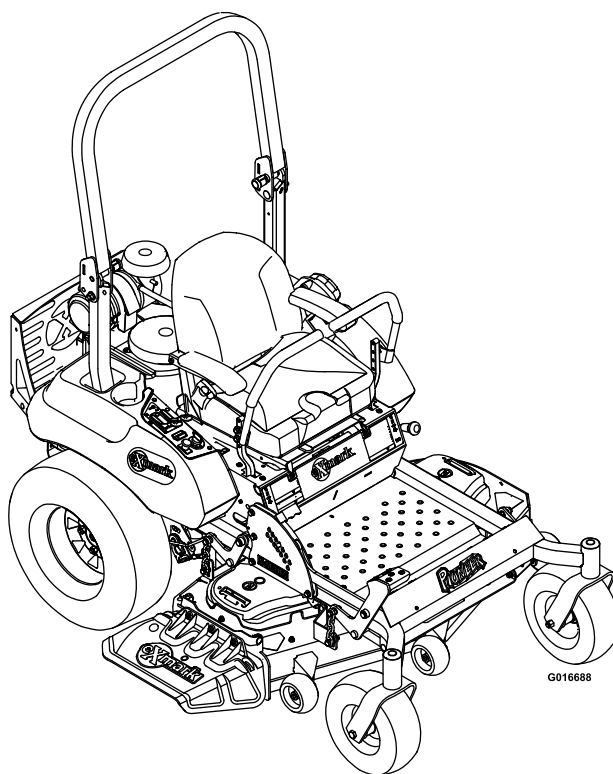

PIONEER S-SERIES

Model No. PNS600KA443—Serial No. 31200000 and Up

Picture below may not reflect actual product.



Parts Manual

Ordering Replacement Parts

To order replacement parts, please supply the part number, the quantity, and the description of each part desired.

Understanding Reference Numbers

Each identified part in an illustration has a reference number. The reference number for a part also appears in the parts list, along with other information about the part.

This catalog uses two special reference number formats, one to indicate parts in a service assembly and another to indicate the quantity of a given part in an illustration.

Service Assembly Reference Numbers

Parts in service assemblies have reference numbers in the form a:b. The a represents the reference number of the entire service assembly and the b represents a sequential number unique to each part within the service assembly.

For example, a wheel assembly might be identified by reference number 6, the tire by 6:1, the valve by 6:2, and the wheel by 6:3. When you order the assembly identified by reference number 6, you receive all parts identified by reference numbers 6:1, 6:2, and 6:3. However, you may also order any part individually. Reference numbers of this type appear in illustration and in parts lists.

Reference Numbers Indicating Quantity

In an illustration, if a reference number indicates more than one part, the reference number has the form nX y. The n represents the quantity of the part, the X is the multiplication symbol, and the y represents the reference number.

For example, in an illustration, the reference number 2X 37 means that two of the parts identified by reference number 37 are indicated.

List of Abbreviations

AR: as required	HJ: hex jam	PTH: phillips truss head
ASM: assembly	HLH: hex lag head	PTO: power-take-off
BBC: blade brake control	HOC: height-of-cut	RH: right hand
BHTF: button head thread forming	HSBH: hex socket button head	ROPS: roll-over protection system
CARR: carriage	HSFH: hex socket flat head	RRB: rear roller brush
CCW: counter clockwise	HSH: hex socket head	SFH: slotted fillister head
CW: clockwise	HWH: hex washer head	SHH: slotted hex head
DEG: degrees	HWHTF: hex washer head thread forming	SHWH: slotted hex washer head
DPA: Dual Point Adjustment	HYD: hydraulic	SPH: slotted pan head
ECM: electronic control module	LH: left hand	SQH: square head
EXT: external	LP: Liquid Propane	SRH: slotted round head
FH: flat head	NI: nylon insert	STD: standard
GA: gauge	NPTF: national pipe thread fine	TAP: self tapping
HD: heavy-duty	PFH: phillips flat head	TTH: torx truss head
HF: hex flange	PPH: phillips pan head	
HH: hex head	PPHTF: phillips pan head thread forming	
HHF: hex head flange	PRH: phillips round head	
HHFTF: hex head flange thread forming		

Touch Up Paint

Exmark black touch up spray paint – gloss black.

Exmark red touch up paint (spray paint – P/N 1-850337 - .6 oz liquid bottle – P/N 103-9140).



If your Exmark dealer does not have the Exmark part in stock, Exmark will get the parts to the dealer the next business day or the part will be FREE Guaranteed!! (Some restrictions apply. See your participating Exmark Dealer for details.)

Contents

Complete Deck Assembly No. 116-4810	4
Deck Assembly	5
Deck W/Decals Assembly No. 116-3194	6
Mainframe Assembly	7
Mainframe W/Decals Assembly No. 116-6829	8
Caster Wheel Assembly No. 103-5189.....	9
Roll-Over Protection System Assembly No. 116-3498.....	10
Deck Lift Assembly.....	11
Motion Control Assembly	12
Motion Control Assembly - LH	13
Motion Control Assembly - RH.....	14
Seat Assembly	15
Seat W/Tracks Assembly No. 116-6192.....	16
Controls Assembly	17
Fuel Tank Mounting Assembly	18
Fuel Tank Assembly No. 116-4610	19
Engine Assembly	20
Hydraulic Assembly	21
Transaxle Assembly.....	22
Electrical Assembly	23
Caster Wheel Assembly No. 103-5189.....	24
Motion Control Assembly	25

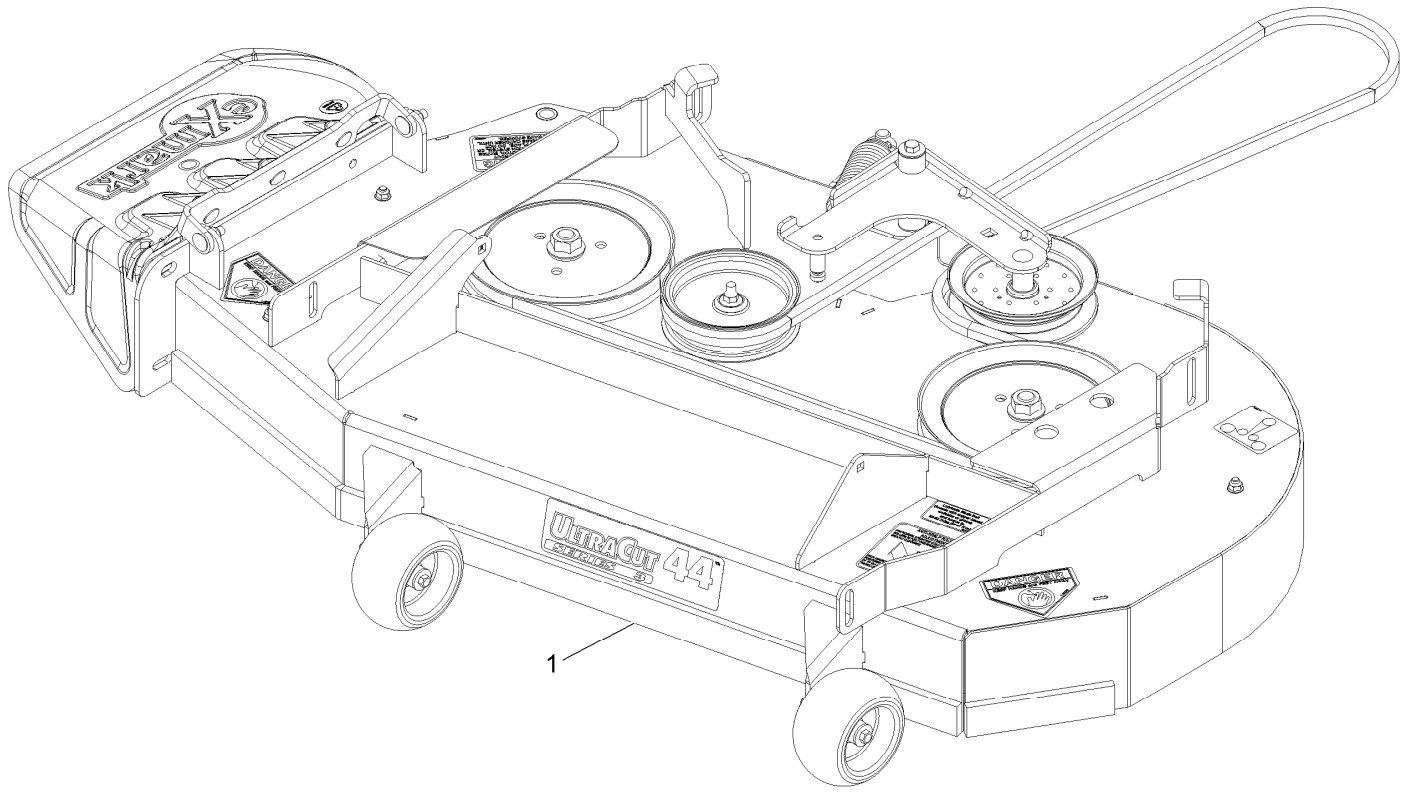

Complete Deck Assembly No. 116-4810

<i>Ref.</i>	<i>Part Number</i>	<i>Qty.</i>	<i>Description</i>
1	116-4810	1	ASM-Deck Complete 443

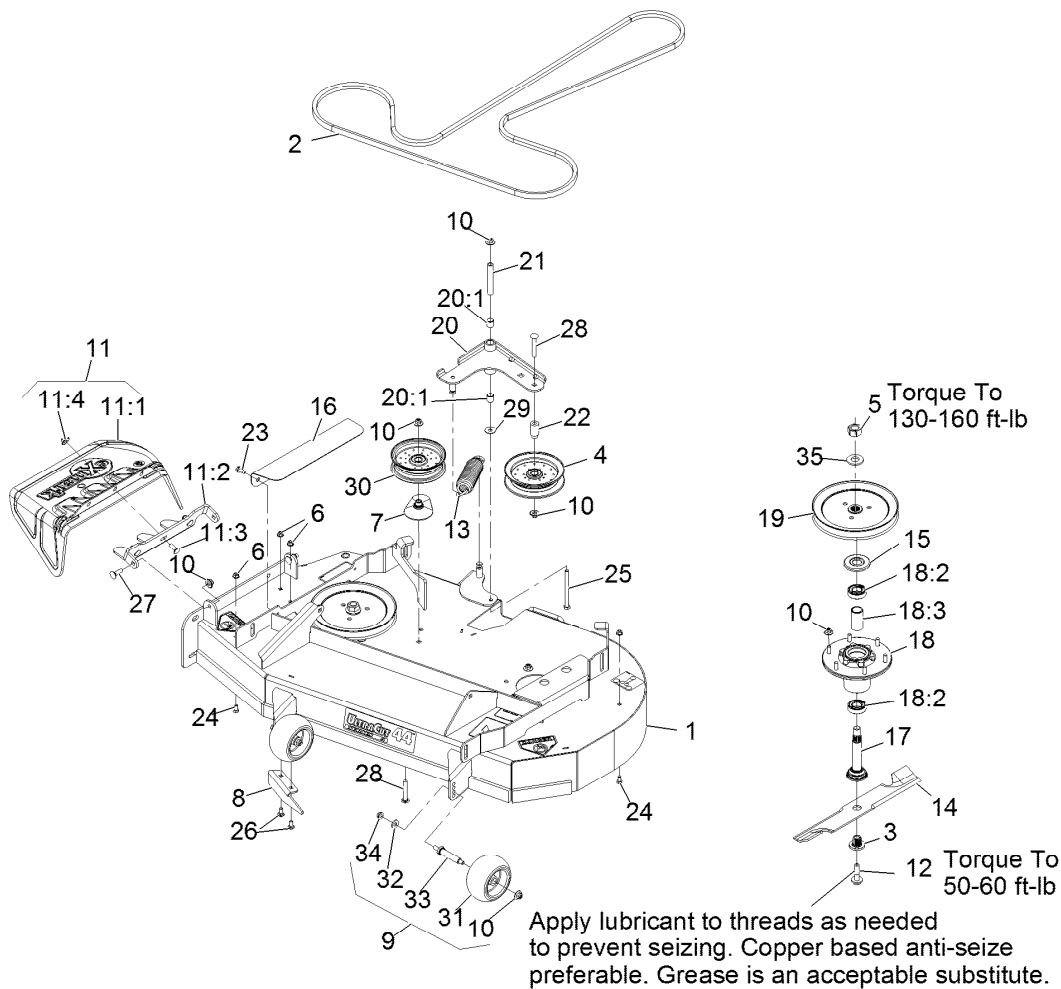

Deck Assembly

Ref.	Part Number	Qty.	Description	Ref.	Part Number	Qty.	Description
1	116-3194	1	ASM-Deck W/Decals 44	18	116-3344	2	ASM-Cutter Hsg With Bearings
2	1-413093	1	Belt, Deck Drive (44")	18:2	116-0720	2	Bearing-Ball
3	103-3037	2	Bushing, Splined	18:3	116-3312	1	Spacer-Bearing
4	116-4668	1	Idler-Pulley, Flanged	19	116-4589	2	Sheave-Blade Drive, 8.40
5	116-7306	2	Nut-Hex	20	116-4693	1	ASM-Idler Arm
6	104-8300	4	Nut-Nyloc 5/16-18 Flg	20:1	1-513034	2	Sleeve-Bearing
7	109-2872	1	Spacer-Pulley	21	116-5111	1	Bushing
8	109-5498-03	1	Baffle-Discharge	22	116-4714	1	Bushing-Idler
9	103-4051	2	Kit, Antiscalp Roller (44" And 48")	23	32144-70	2	Screw-HWH 5/16-18 X 3/4 Tf
10	109-6658	19	Nut-Nyloc 3/8-16 Flg	24	322-2	2	Screw-HH 5/16-18 X 5/8
11	109-7188	1	ASM,Discharge Chute	25	323-23	1	Screw-HH 3/8-16 X 4-1/2
11:1	109-2738	1	Chute, Discharge	26	3230-1	2	Bolt-Carriage 5/16-18 X 3/4
11:2	109-8675-01	1	Bracket,Discharge Chute	27	3231-25	2	Bolt-Carriage 3/8-16 X 1 1/4
11:3	3231-22	3	Bolt-Carriage 3/8-16 X 1	28	3231-44	2	Bolt-Carriage 3/8-16 X 2 1/2
11:4	109-6658	3	Nut-Nyloc 3/8-16 Flg	29	52-2860	1	Washer
12	109-9220	2	Screw-Sems 1/2-20 X 2.19	30	116-4669	1	Pulley-Idler Flat
13	116-6317	1	Spring-Extension	31	1-603299	2	Roller-Scalp, Anti
14	116-1047	2	Blade-Mulch, 22.25 ●	32	98-5975	2	Washer-Spring Disc 3/8
14	116-1037	2	Blade-Notched, 22.25	33	99-2842	2	Spacer
15	116-1286	2	Guard,Bearing Top .989	34	3290-357	2	Nut-Whizlock 3/8-16
16	116-2828-01	1	Cover,Belt	35	103-2802	2	Washer-Spring Disc 3/4
17	116-3342	2	ASM-Spindle And Seal				

● Requires installation of mulch kit for proper mulching. See your Exmark dealer for details.

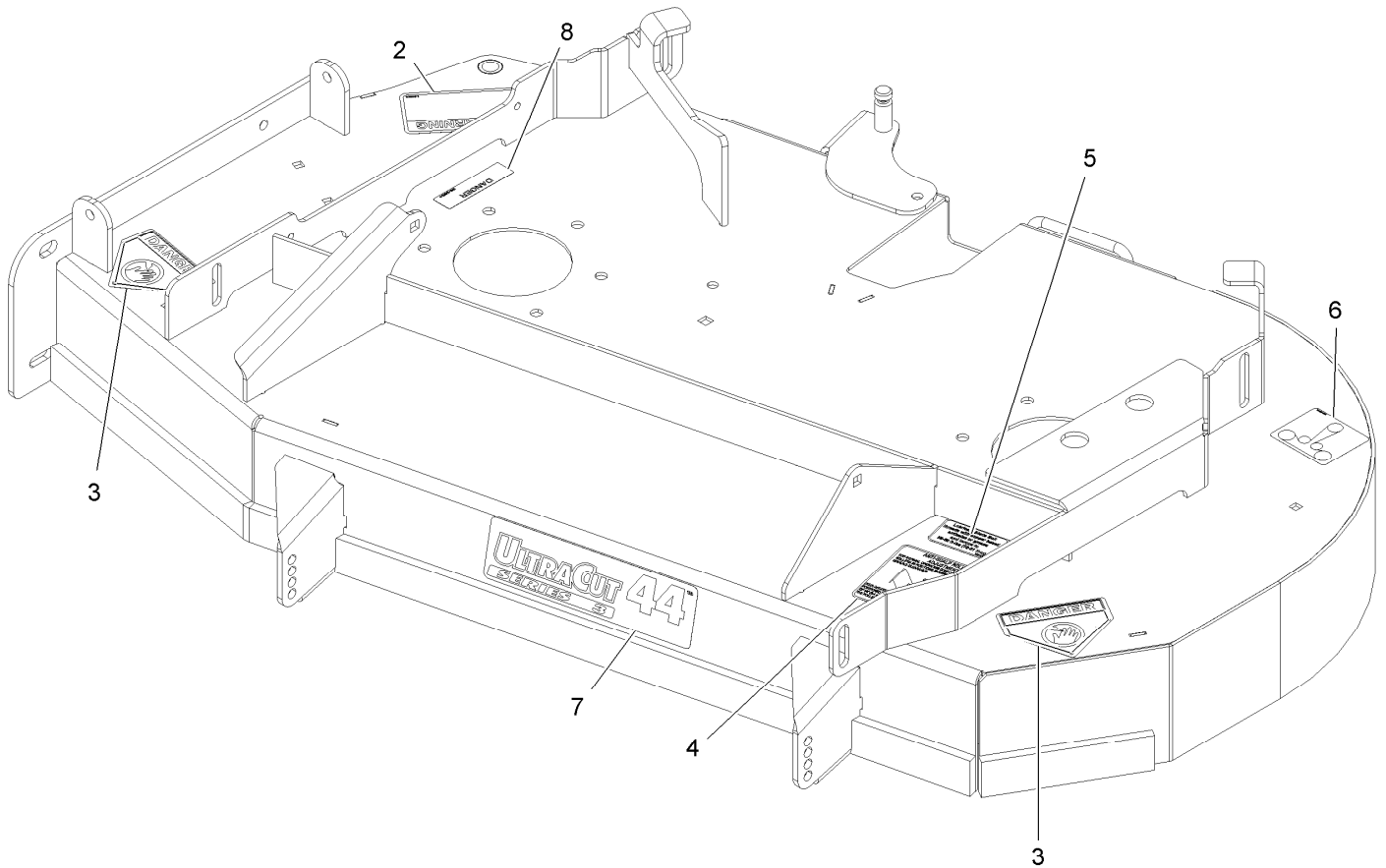

Deck W/Decals Assembly No. 116-3194

<i>Ref.</i>	<i>Part Number</i>	<i>Qty.</i>	<i>Description</i>
2	1-303508	1	Decal-Warning, Discharge
3	1-403005	2	Decal-Danger
4	1-633922	1	Decal, Anti-Scalp
5	109-3148	1	Decal, Bolt Torque
6	109-6014	1	Decal-Belt Routing
7	116-4795	1	Decal-Ultracut 44 Series 3
8	98-5954	1	Decal-Cover, Missing

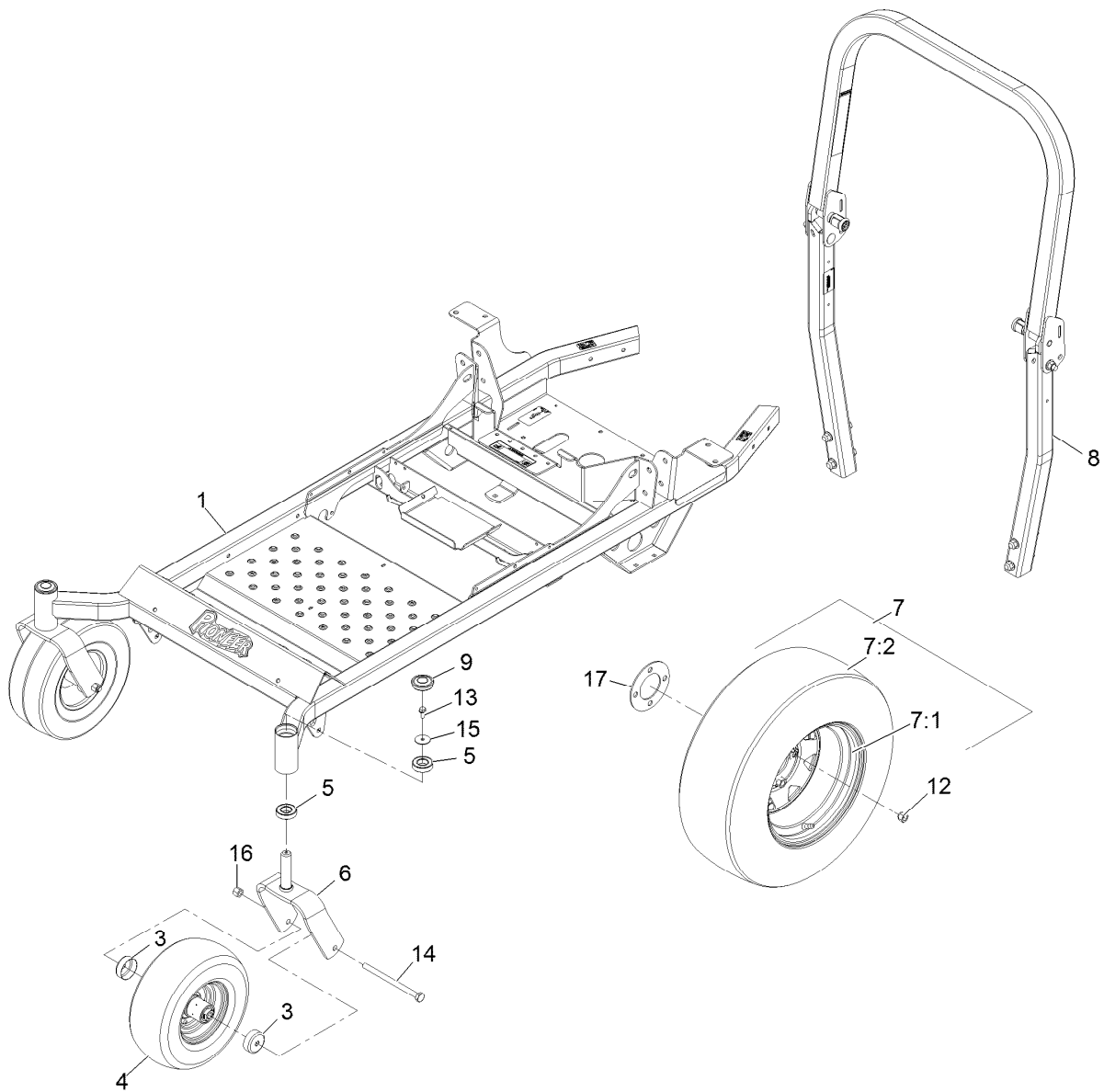

Mainframe Assembly

Ref.	Part Number	Qty.	Description
1	116-6829	1	Frame ASM-44
3	103-2768	4	Guard-Seal
4	103-5189	2	Asm, Caster Wheel (Pneumatic)
5	109-3678	4	Bearing-Ball
6	116-0611-01	2	Wld,Caster Fork
7	116-3166	2	ASM,Wheel And Tire 22 X 9.50 - 12
7:1	116-3167	1	Wheel

Ref.	Part Number	Qty.	Description
7:2	116-1948	1	Tire
8	116-3498	1	ASM-ROPS Pioneer
9	116-4348	2	Cap-Grease
12	242-50	8	Nut-Lug 1/2-20
13	3234-5	2	Screw-HH Flg 5/16-18 X 3/4
14	325-36	2	Screw-HH 1/2-13 X 7 1/2
15	3256-68	2	Washer-Flat
16	3296-23	2	Nut-Nyloc 1/2-13
17	116-5362	2	Spacer-Wheel

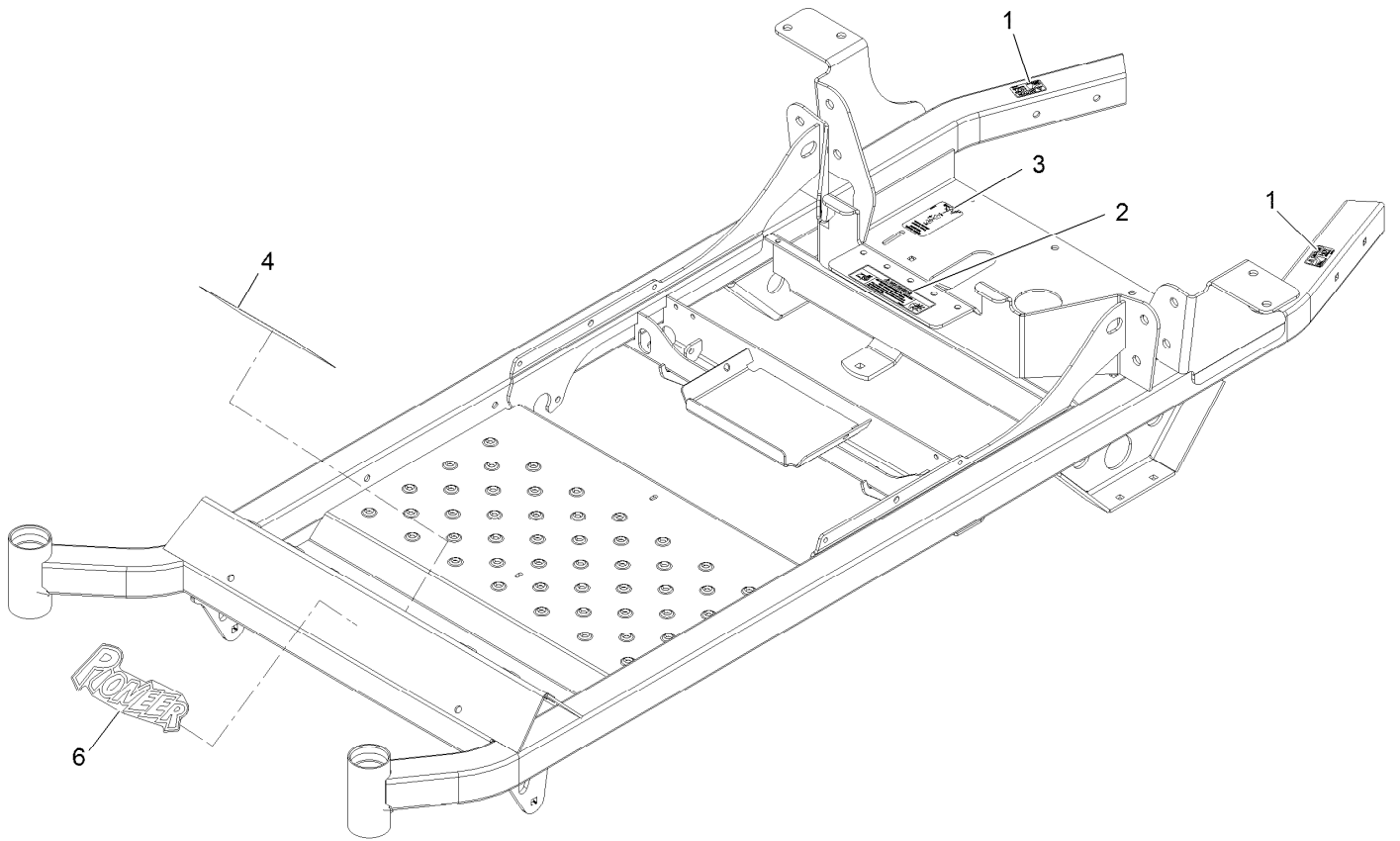

Mainframe W/Decals Assembly No. 116-6829

<i>Ref.</i>	<i>Part Number</i>	<i>Qty.</i>	<i>Description</i>
1	103-2076	2	Decal-Caution
2	116-1119	1	Decal,Belt Drive
3	116-6363	2	Decal-Drive Release
4	116-3303	1	Decal-Slope
6	116-4570	1	Decal-Pioneer Logo

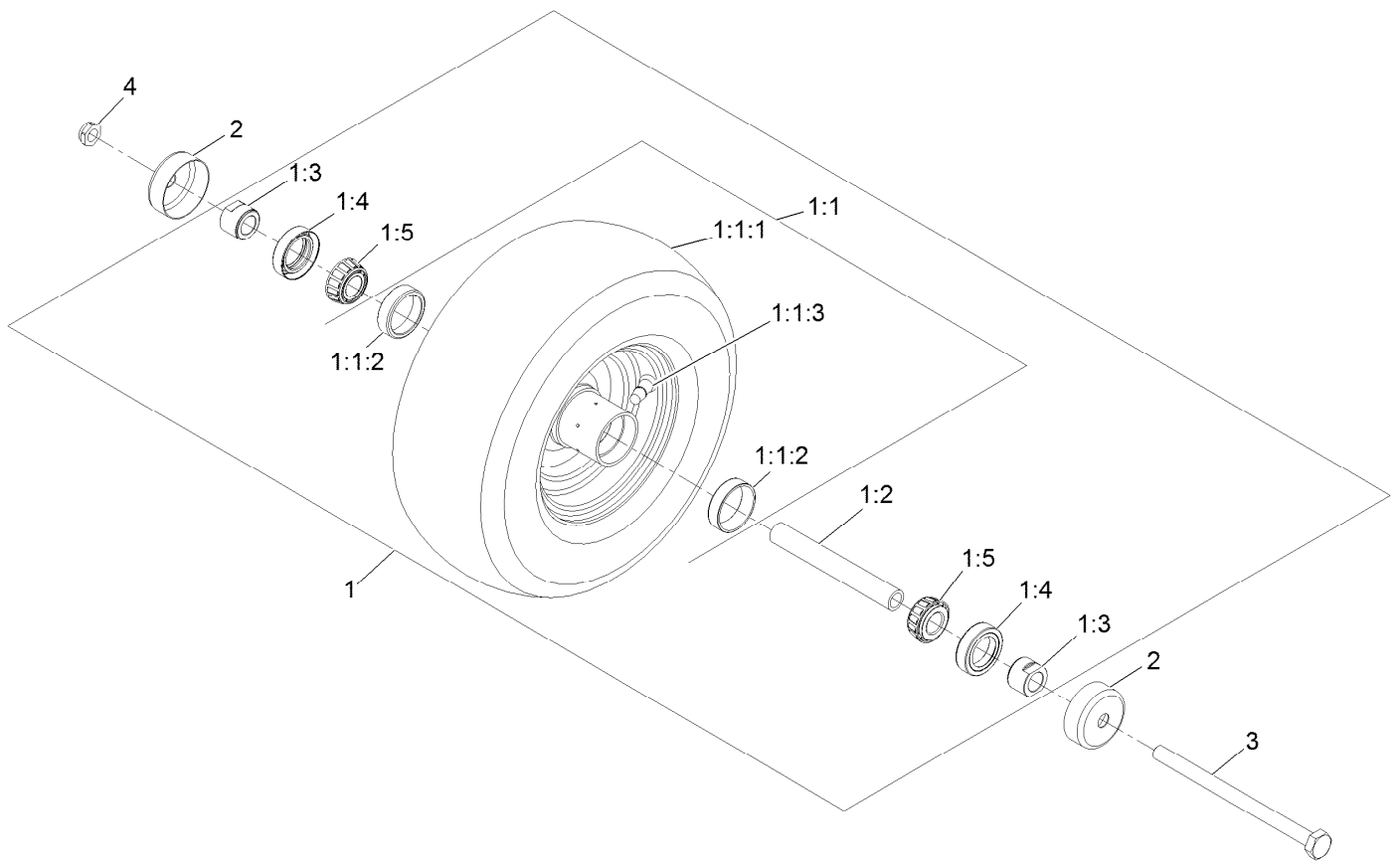

Caster Wheel Assembly No. 103-5189

Ref.	Part Number	Qty.	Description
1		1	ASM, Wheel And Brg 13X5.00-6 ●
1:1		1	ASM, Wheel And Tire 13X5.00-6 ●
1:1:1	1-633002	1	Tire
1:1:2	1-633584	2	Bearing-Cup
1:1:3	5108	1	Valve
1:2	103-3155	1	Axle-Caster
1:3	103-3051	2	Spacer-Nut ■
1:4	103-0063	2	Seal-Double Lip
1:5	1-633585	2	Bearing-Cone Tapered Roller
2	103-2768	2	Guard-Seal
3	325-36	1	Screw-HH 1/2-13 X 7 1/2
4	3296-45	1	Nut-Nyloc 1/2-13 Thin

● Not serviced separately

■ Use Pro-Lock, Nut Type (P/N 1-840022, .5ml tube) on threads.

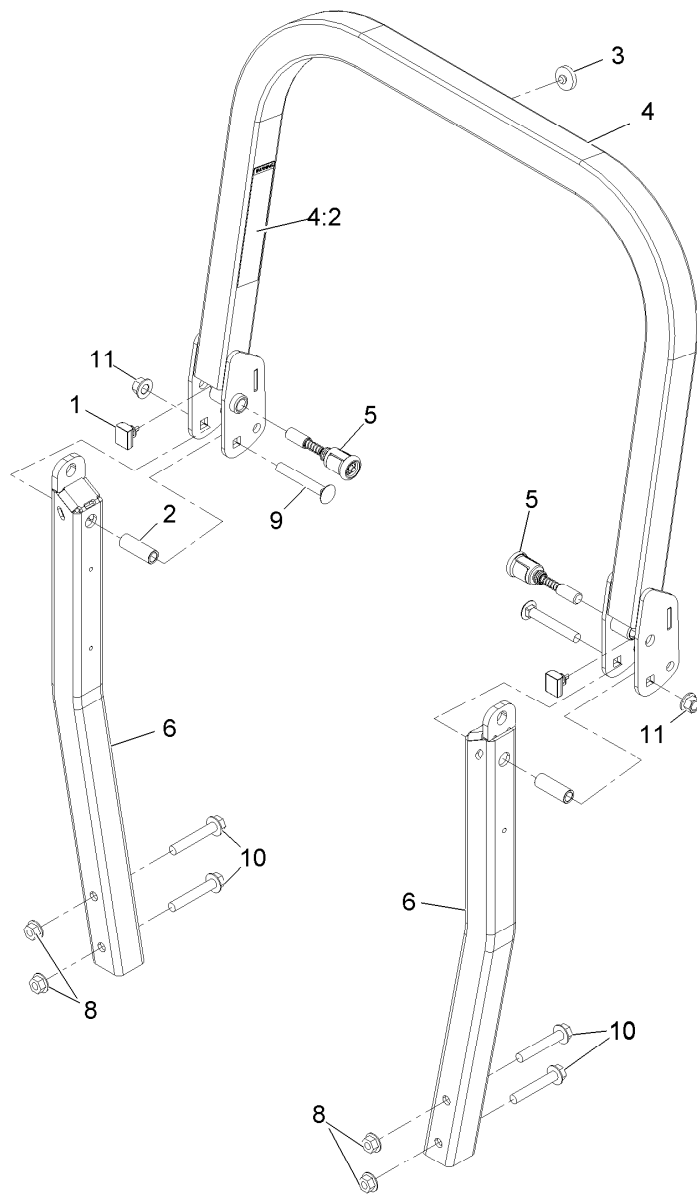

Roll-Over Protection System Assembly No. 116-3498

Ref.	Part Number	Qty.	Description
1	109-5337	2	Bumper-ROPS
2	109-6653	2	Spacer
3	109-9233	1	Bumper-Push-In, Rubber
4	116-0019	1	Upper ROPS ASM
4:2	107-2102	1	Decal-Warning, Folding ROPS
5	116-0104	2	Spring Pin ASM
6		2	ASM-Lwr ROPS Leg ●
8	32128-49	4	Nut-Whizlock 1/2-13
9	3233-10	2	Bolt-Carriage 1/2-13 X 3 1/2
10	3234-40	4	Screw-HF
11	99-5107	2	Nut-Lock 1/2-13

● Not serviced separately

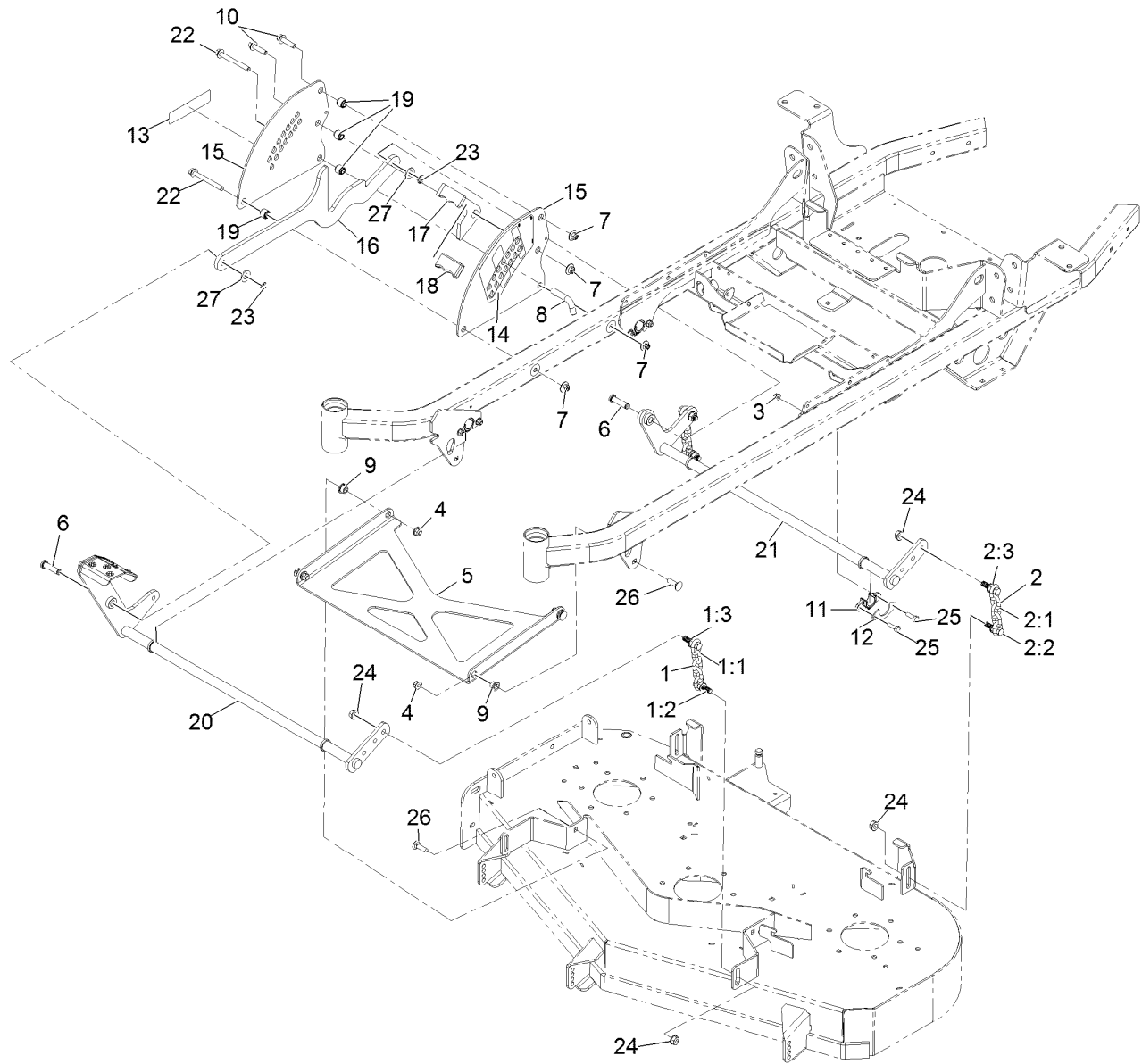

Deck Lift Assembly

Ref.	Part Number	Qty.	Description	Ref.	Part Number	Qty.	Description
1	103-9792	2	Deck Chain ASM	11	115-5065	4	Bushing-Flange
1:1	1-633447	1	Chain-Lift, Deck	12	116-2887	4	Gusset-Deck Lift
1:2	103-1898	2	Screw-HH 7/16-20 X 1-5/8 Sp	13	116-3884	1	Decal-S-Series
1:3	32128-37	2	Nut-Whizlock 7/16-14	14	116-4308	1	Decal-Height Of Cut
2	103-9817	2	Deck Chain ASM	15	116-4309-03	2	Plate,Deck Lift
2:1	1-633447	1	Chain-Lift, Deck	16	116-4310-03	1	Link-HOC
2:2	103-1898	2	Screw-HH 7/16-20 X 1-5/8 Sp	17	116-4311	1	Transport Lock-HOC
2:3	32128-37	2	Nut-Whizlock 7/16-14	18	116-4312	1	Grip-3/8 X 1 Flat Bar
3	104-8300	8	Nut-Nyloc 5/16-18 Flg	19	116-4313	4	Spacer-Double Step
4	104-8301	4	Nut-Nyloc 3/8-16 Flg	20	116-6011-03	1	Wld-Deck Lift Shaft Frt
5	109-3723-01	1	Strut-Deck	21	116-6012-03	1	Wld-Deck Lift Shaft Rr
6	109-5819	2	Pin-Clevis	22	116-4701	2	Screw-HHF
7	109-6658	4	Nut-Nyloc 3/8-16 Flg	23	32120-47	2	Ring-Retaining
8	116-5584	1	Pin-HOC	24	32128-37	8	Nut-Whizlock 7/16-14
9	109-8788	4	Bushing-Flanged	25	322-5	8	Screw-HH 5/16-18 X 1
10	114-4681	2	Screw-HHF	26	3231-25	4	Bolt-Carriage 3/8-16 X 1 1/4
				27	3256-26	2	Washer-1/2 Sae

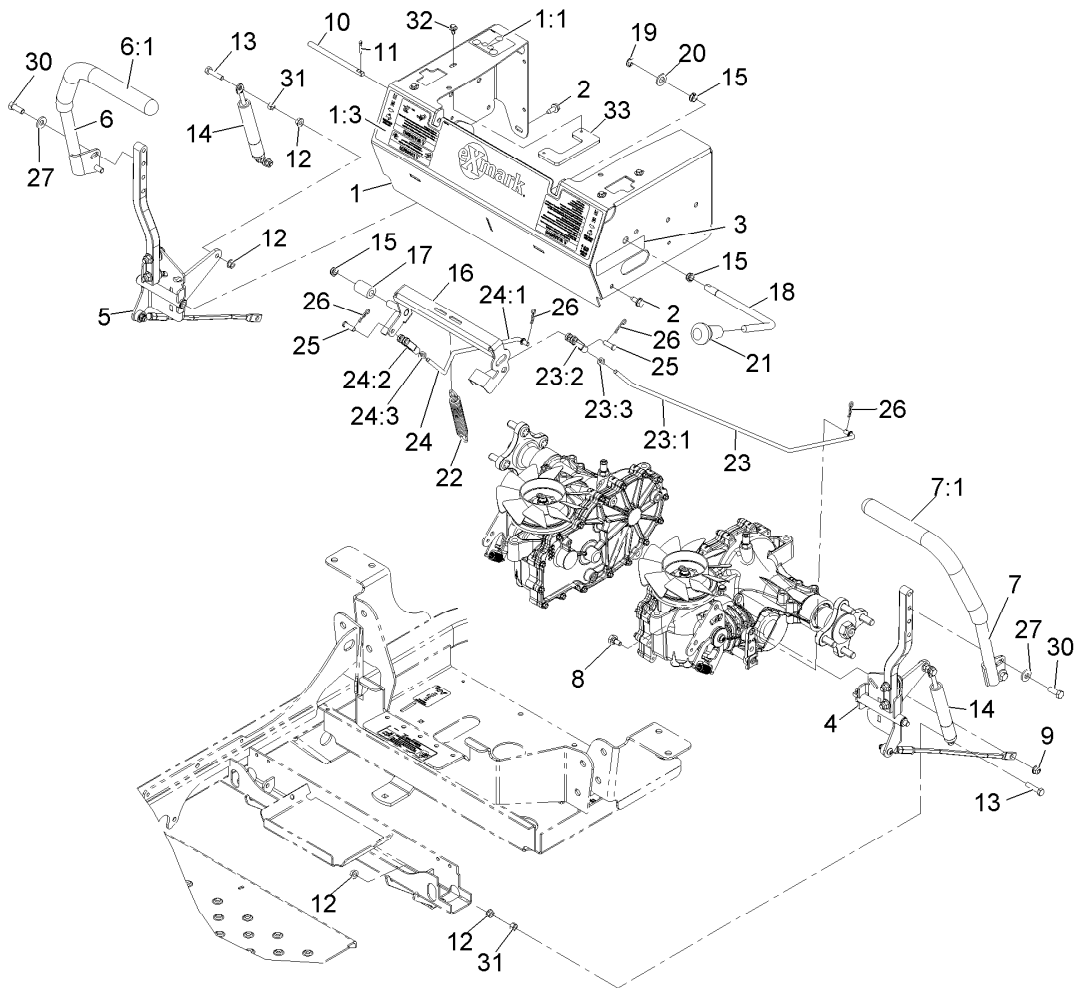

Motion Control Assembly

Ref.	Part Number	Qty.	Description	Ref.	Part Number	Qty.	Description
1	116-3188	1	ASM-Mot Ctrl Frm W/Dcl	16	116-6233	1	ASM-Brake Center Arm
1:1	109-6014	1	Decal-Belt Routing	17	109-5010	1	Spacer
1:3	116-4430	1	Decal-Front Panel	18	116-3155	1	Handle, Brake
2	32144-70	6	Screw-HWH 5/16-18 X 3/4 Tf	19	32120-47	1	Ring-Retaining
3	116-3884	1	Decal-S-Series	20	106-9888	1	Washer-Flat
4		1	Motion Control ASM-LH ●	21	106-7952	1	Knob
5		1	Motion Control ASM-RH ●	22	88-6130	1	Spring-Deck, Engagement
6	119-3486	1	RH Handle ASM	23	116-1165	1	Brake Linkage ASM-LH
6:1	108-6187	1	Grip	23:1	116-1167	1	Linkage, Brake LH
7	119-3485	1	LH Handle ASM	23:2	1-303105	1	Yoke-Adjustable
7:1	108-6187	1	Grip	23:3	3220-2	1	Nut-Jam 5/16-24
8	37-8771	2	Screw-Shoulder 5/16-18 X 5/8	24	116-1166	1	Brake Linkage ASM-RH
9	104-8300	2	Nut-Nyloc 5/16-18 Flg	24:1	116-1168	1	Linkage-Brake, RH
10	109-3705	2	Pin-Control Pivot	24:2	1-303105	1	Yoke-Adjustable
11	3272-10	2	Pin-Cotter 1/8 X 3/4	24:3	3220-2	1	Nut-Jam 5/16-24
12	32128-20	8	Nut-Whizlock 5/16-18	25	1-808280	2	Pin-Clevis 5/16 X 1 49/64
13	1-403180	4	Screw-HH 5/16-18 X 1 1/4 Sp	26	1-806003	4	Hairpin-Cotter
14	109-5957	2	Damper-Motion Control	27	98-5975	4	Washer-Spring Disc 3/8
15	116-1393	3	Bushing, Snap	30	323-6	4	Screw-HH 3/8-16 X 1
				31	3217-6	4	Nut-Hex 5/16-18
				32	46-8560	4	Screw-HHF 1/4-20 X 1/2
				33	109-6214	2	Stop-Motion Control

● Not serviced separately

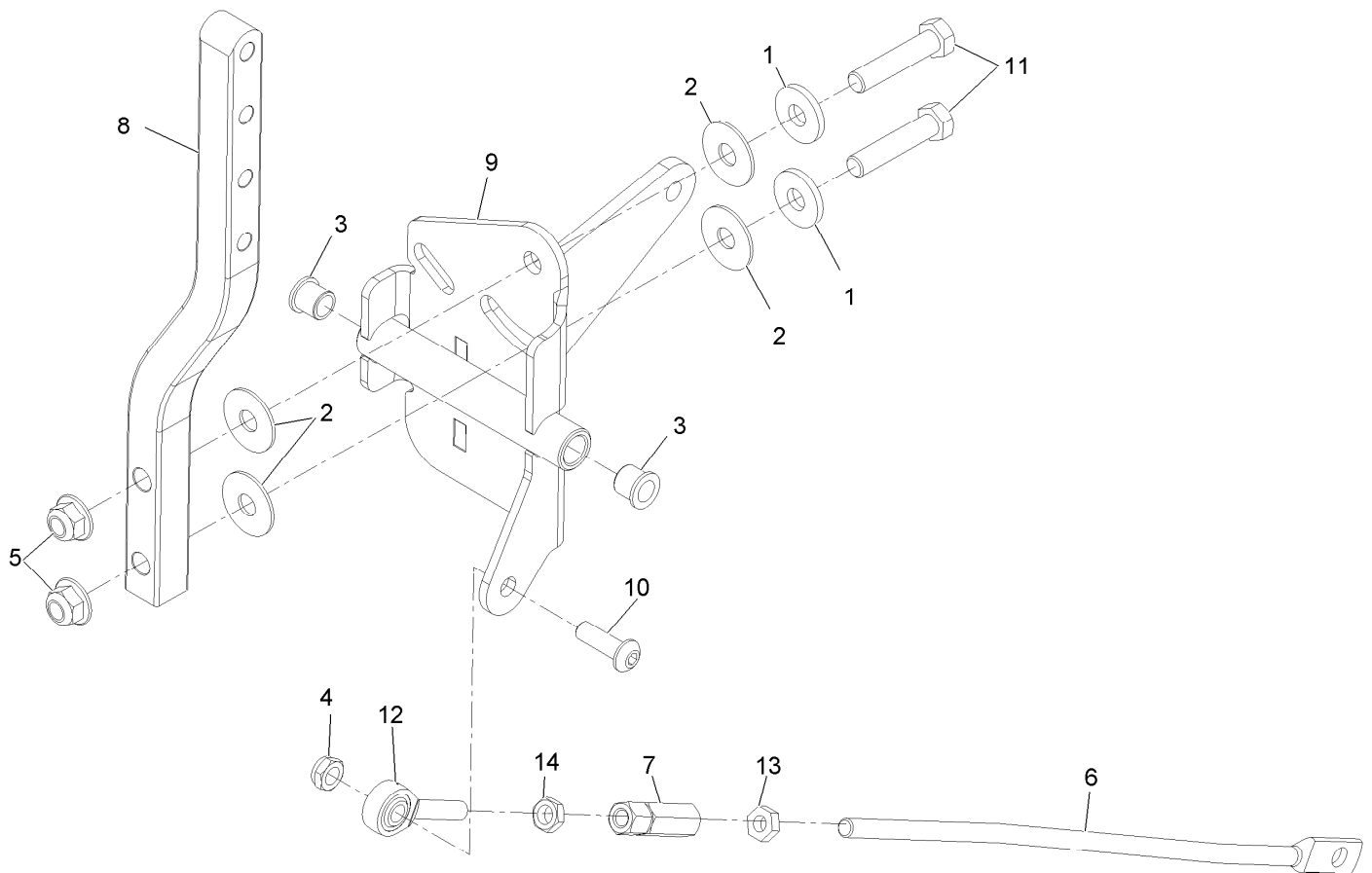

Motion Control Assembly - LH

Ref.	Part Number	Qty.	Description
1	5-0838	2	Washer
2	52-2900	4	Washer-Plastic
3	103-9928	2	Bearing
4	3296-47	1	Nut-Nyloc 5/16-18 Thin
5	104-8301	2	Nut-Nyloc 3/8-16 Flg
6	116-2543	1	Link, Motion Control
7	109-3728	1	Nut-Rod Adjustment
8	116-3183	1	Arm-Motion Control
9	116-3176	1	LH Control Pivot ASM
10	3274-104	1	Screw-Button Head 5/16-18 X 1
11	323-9	2	Screw-HH 3/8-16 X 1 3/4
12	2411-53	1	Balljoint LH
13	3220-2	1	Nut-Jam 5/16-24
14	3220-20	1	Nut-Jam 5/16-24 LH

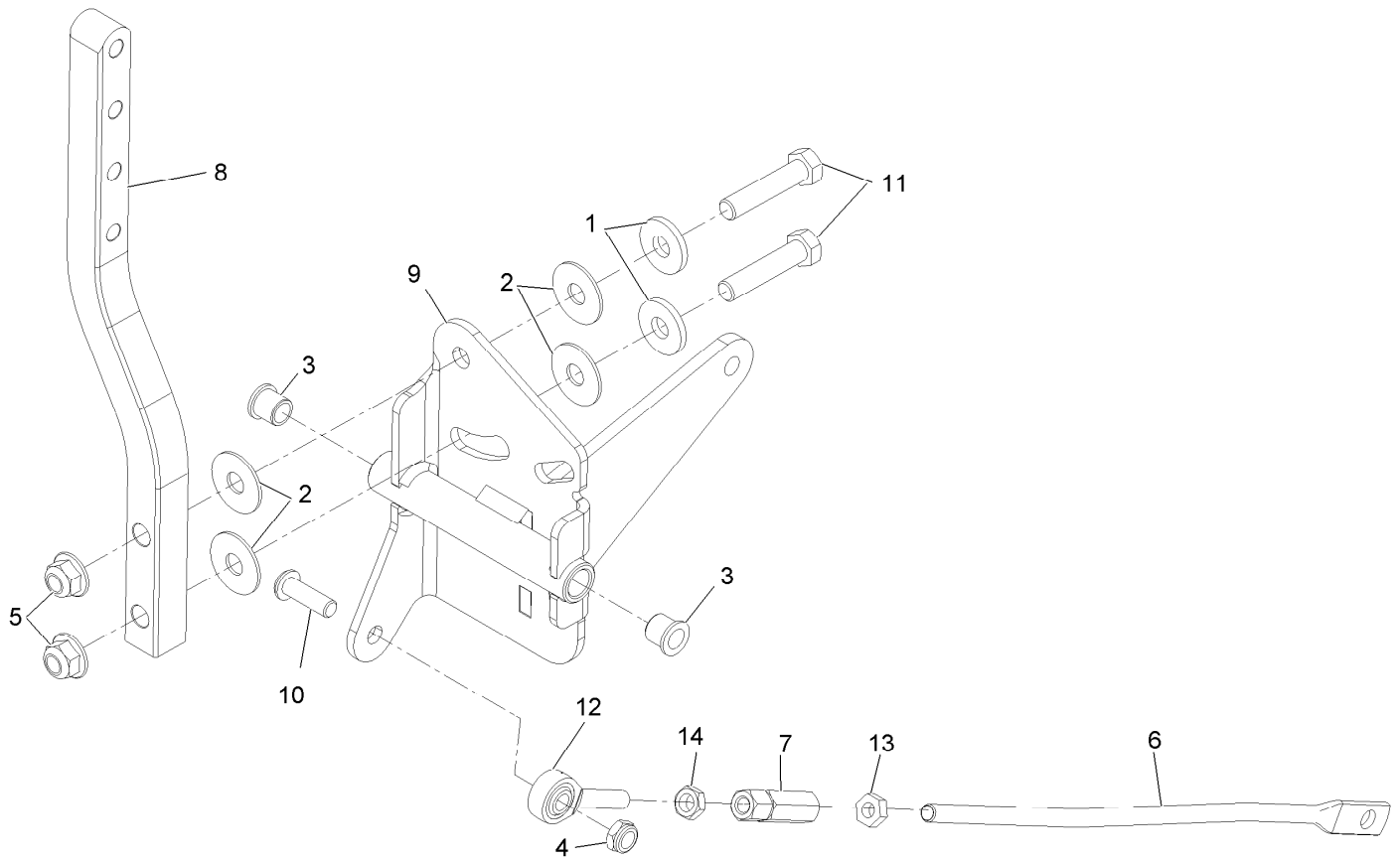

Motion Control Assembly - RH

Ref.	Part Number	Qty.	Description
1	5-0838	2	Washer
2	52-2900	4	Washer-Plastic
3	103-9928	2	Bearing
4	3296-47	1	Nut-Nyloc 5/16-18 Thin
5	104-8301	2	Nut-Nyloc 3/8-16 Flg
6	116-2543	1	Link, Motion Control
7	109-3728	1	Nut-Rod Adjustment
8	116-3183	1	Arm-Motion Control
9	116-3179	1	RH Control Pivot ASM
10	3274-104	1	Screw-Button Head 5/16-18 X 1
11	323-9	2	Screw-HH 3/8-16 X 1 3/4
12	2411-53	1	Balljoint LH
13	3220-2	1	Nut-Jam 5/16-24
14	3220-20	1	Nut-Jam 5/16-24 LH

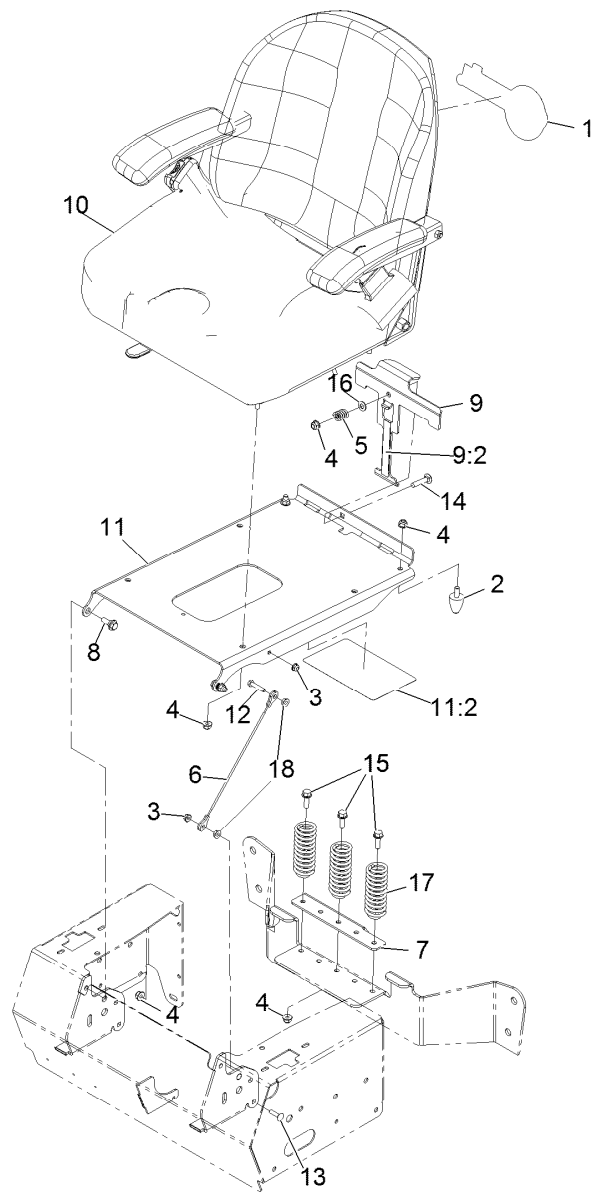

Seat Assembly

<i>Ref.</i>	<i>Part Number</i>	<i>Qty.</i>	<i>Description</i>	<i>Ref.</i>	<i>Part Number</i>	<i>Qty.</i>	<i>Description</i>
1	103-2882	1	Decal, Exmark Logo	11	116-4418	1	Plate, Seat W/Decals
2	103-9376	2	Bumper-Seat	11:2	109-6016	1	Decal-Service Aid
3	104-7201	2	Nut-Nyloc 1/4-20 Flg	12	321-8	1	Screw-HH 1/4-20 X 1 1/4
4	104-8300	12	Nut-Nyloc 5/16-18 Flg	13	3229-2	1	Bolt-Carriage 1/4-20 X 1
5	107-3017	1	Spring-Compression	14	3230-4	1	Bolt-Carriage 5/16-18 X 1 1/2
6	109-2628	1	Cable-Stop, Seat	15	3234-29	3	Screw-HH Flg 5/16-18 X 1
7	116-0871	1	Catch,Seat Latch	16	3256-23	1	Washer-5/16 Sae
8	116-1297	2	Screw-Shoulder	17	92-7054	3	Spring-Compression
9	116-3121	1	ASM-Seat Latch	18	32128-33	2	Nut-Whizlock 1/4-20
9:2	116-3120	1	Strip-Poly Wear				
10	116-6192	1	ASM-Seat, Lze				

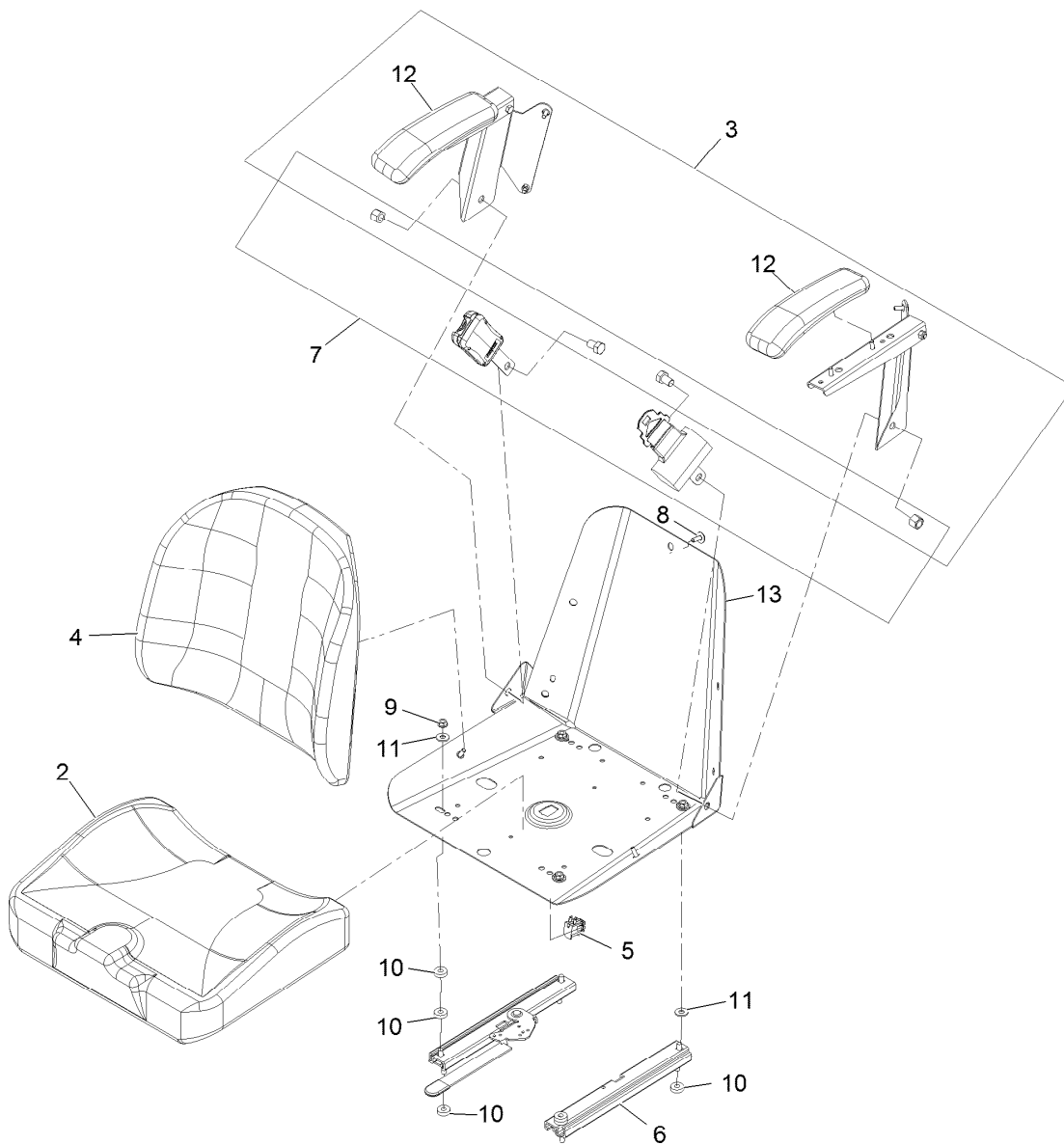

Seat W/Tracks Assembly No. 116-6192

<i>Ref.</i>	<i>Part Number</i>	<i>Qty.</i>	<i>Description</i>
2	116-7329	1	Cushion-Seat Bottom
3	110-5719	1	Armrest Kit
4	116-3738	1	Cushion,Seat Back
5	82-2190	1	Switch
6	1-643255	1	Track-Seat
7	116-2981	1	Seat Belt Kit
8	103-8383	7	Screw-HWH 1/4-20 X 3/4 Taptite
9	32128-20	4	Nut-Whizlock 5/16-18
10	26-4840	8	Spacer-Pin, Mounting
11	3256-3	6	Washer-5/16 Std
12	110-4163	2	Cushion-Rest, Arm
13	116-7496	1	Frame-Seat

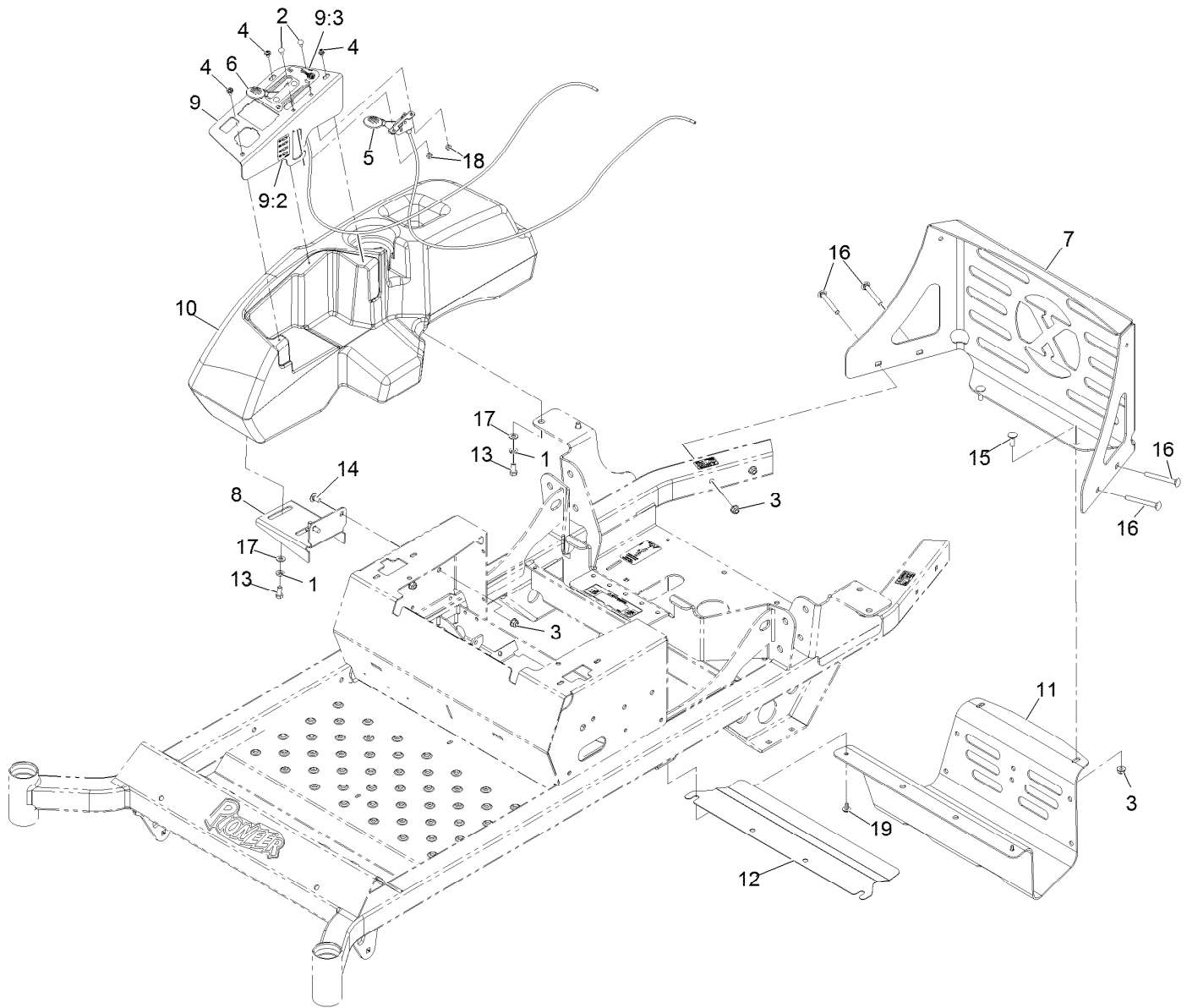

Controls Assembly

Ref.	Part Number	Qty.	Description
1	1-805005	4	Washer-Lock 5/16 Heavy
2	1-807513	4	Bolt-Carriage #10-24 X 1/2
3	104-8300	8	Nut-Nyloc 5/16-18 Flg
4	109-2661	3	Screw-PPH #10-24 X 1/2
5	116-4919	1	Control, Throttle
6	109-8747	1	Control, Choke
7	116-3453-03	1	Panel, Rear Guard
8	116-3495-03	1	Bracket-Tank And Fender
9	116-3496	1	ASM, Control Panel W/Decal
9:2	116-1496	1	Decal, Fuse Block
9:3	116-4465	1	Decal-Throttle Choke

Ref.	Part Number	Qty.	Description
10	116-4138	1	Console, RH
11	116-4708-03	1	Guard-Muffler
12	116-6004-03	1	Shield-Heat Deflector
13	322-3	4	Screw-HH 5/16-18 X 3/4
14	3230-18	2	Bolt-Carriage 5/16-18 X 5/8
15	3230-2	2	Bolt-Carriage 5/16-18 X 1
16	3230-9	4	Bolt-Carriage 5/16-18 X 2 3/4
17	3256-23	4	Washer-5/16 Sae
18	3296-2	4	Nut-Nyloc #10-24
19	46-8560	2	Screw-HHF 1/4-20 X 1/2

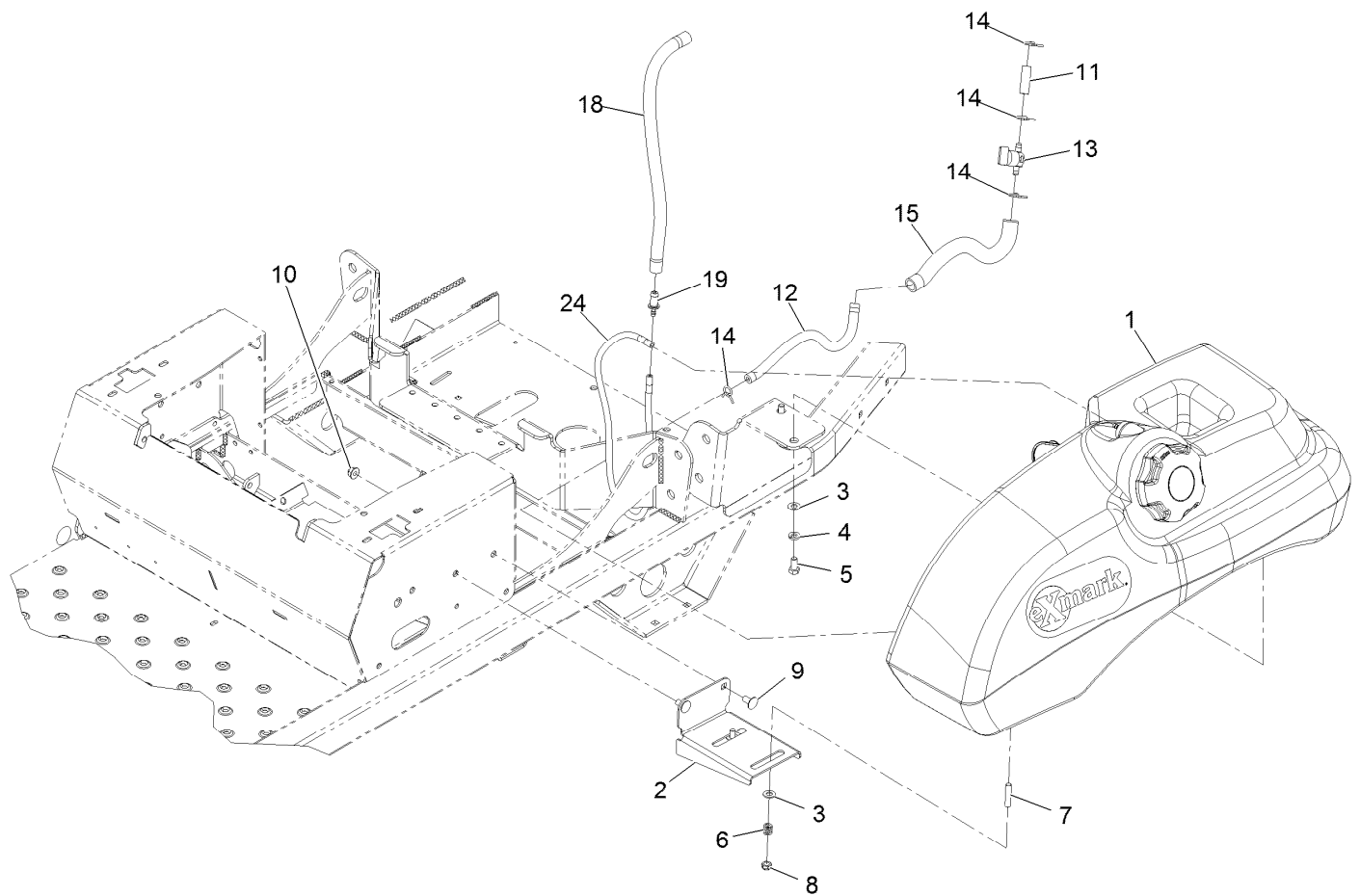

Fuel Tank Mounting Assembly

Ref.	Part Number	Qty.	Description	Ref.	Part Number	Qty.	Description
1	116-4610	1	ASM-Fuel Tank	10	104-8300	2	Nut-Nyloc 5/16-18 Flg
2	116-3495-03	1	Bracket-Tank And Fender	11	106-9492	1	Hose-Fuel
3	3256-23	4	Washer-5/16 Sae	12	109-0282	1	Hose-Fuel
4	1-805005	2	Washer-Lock 5/16 Heavy	13	1-603770	1	Valve-Fuel
5	322-3	2	Screw-HH 5/16-18 X 3/4	14	1-303077	4	Clamp-Fuel Line
6	1-633349	2	Spring-Compression	15	116-4515	1	Conduit-Fuel Line
7	1-633023	2	Stud-Fuel Tank ●	18	116-4344	1	Hose-Fuel
8	3296-47	2	Nut-Nyloc 5/16-18 Thin	19	116-4630	1	Fitting-Straight Orifice
9	3230-18	2	Bolt-Carriage 5/16-18 X 5/8	24	116-4802	1	Hose,Emissions

● Use Pro-Lock, Nut Type (P/N 1-840022, .5ml tube) on threads.

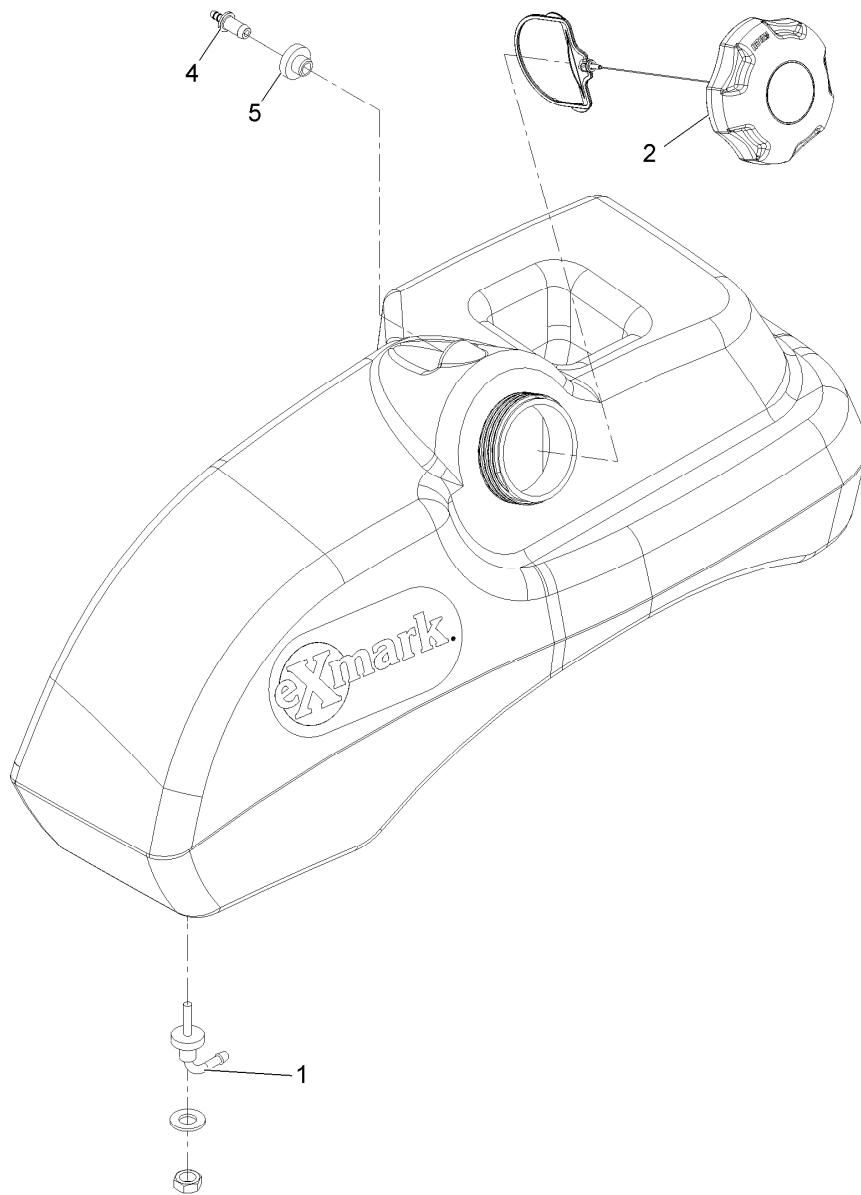

Fuel Tank Assembly No. 116-4610

<i>Ref.</i>	<i>Part Number</i>	<i>Qty.</i>	<i>Description</i>
1	103-2605	1	Fitting-Fuel Bulkhead W/Strainer ●
2	120-5461	1	Cap-Fuel, Ratcheting
4	116-4630	1	Fitting-Straight Orifice
5	46-6560	1	Bushing

● Use Pro-Lock, Nut Type (P/N 1-840022, .5ml tube) on threads.

Kawasaki Replacement Parts List
(Refer To Engine Owner's Manual)

Description	Kawasaki Part
Engine Oil Filter	49065-7007
Engine Air Filter	11013-7048
Fuel Filter	49019-7005

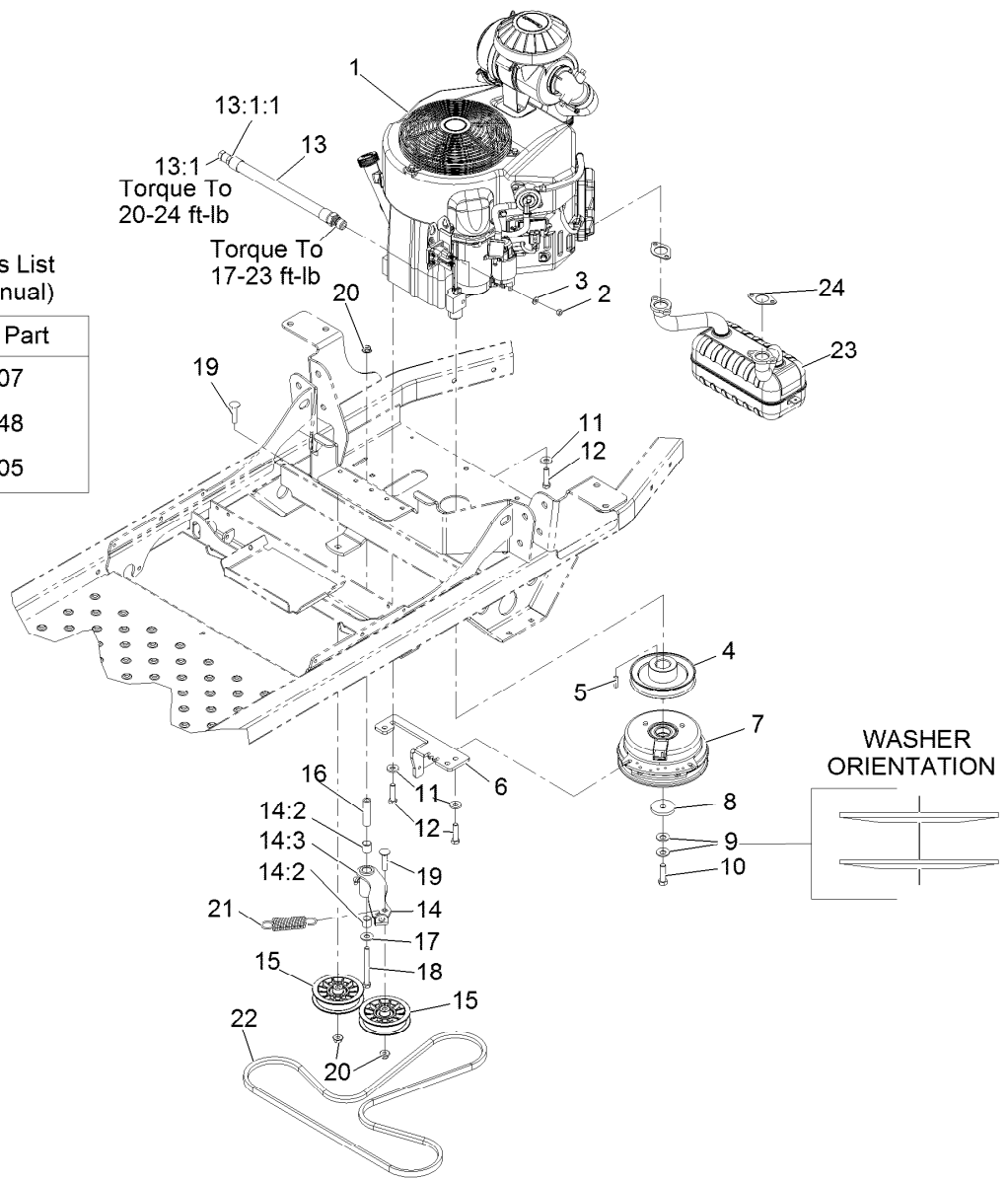

Engine Assembly

Ref.	Part Number	Qty.	Description	Ref.	Part Number	Qty.	Description
1		1	Engine-Kawasaki ●■	13:1:1	237-42	1	O-Ring
2	3217-5	1	Nut-Hex 1/4-20	14	116-4729	1	ASM-Idler Arm W/Bearings
3	3256-22	1	Washer-1/4 Sae	14:2	1-513034	2	Sleeve-Bearing
4	116-1946	1	Sheave-Pump, Drive	14:3	302-40	1	Zerk-90° 1/4-28
5	1-807259	1	Key-Machine 1/4 X 1/4 X 1	15	116-2456	2	Pulley-Flat, 3.50 Dia
6	116-4773-03	1	Anchor-Clutch	16	1-603384	1	Bushing-Pivot, Idler
7	116-1947	1	Clutch	17	3256-4	1	Washer-3/8 Std
8	109-6919	1	Washer-Clutch	18	323-15	1	Screw-HH 3/8-16 X 3 1/2
9	1-603610	2	Washer-Spring Disc 7/16	19	3231-5	2	Bolt-Carriage 3/8-16 X 1 3/4
10	109-9761	1	Band, Brake ◆	20	104-8301	3	Nut-Nyloc 3/8-16 Flg
11	98-5975	4	Washer-Spring Disc 3/8	21	1-603402	1	Spring-Extension
12	323-8	4	Screw-HH 3/8-16 X 1 1/2	22	115-9613	1	V-Belt
13	116-4924	1	Asm-Hose Oil Drain W/Plug ▲	23	116-2450	1	Muffler-Kawasaki
13:1	353-508	1	Plug-W/O-Ring	24	1-653313	2	Gasket-Exhaust

● Not serviced separately

▲ Use a Teflon Pipe Sealant or equivalent on threads.

◆ Use Pro-Lock, Nut Type (P/N 1-840022, .5ml tube) on threads.

■ Obtain parts from www.kawpowerepc.com

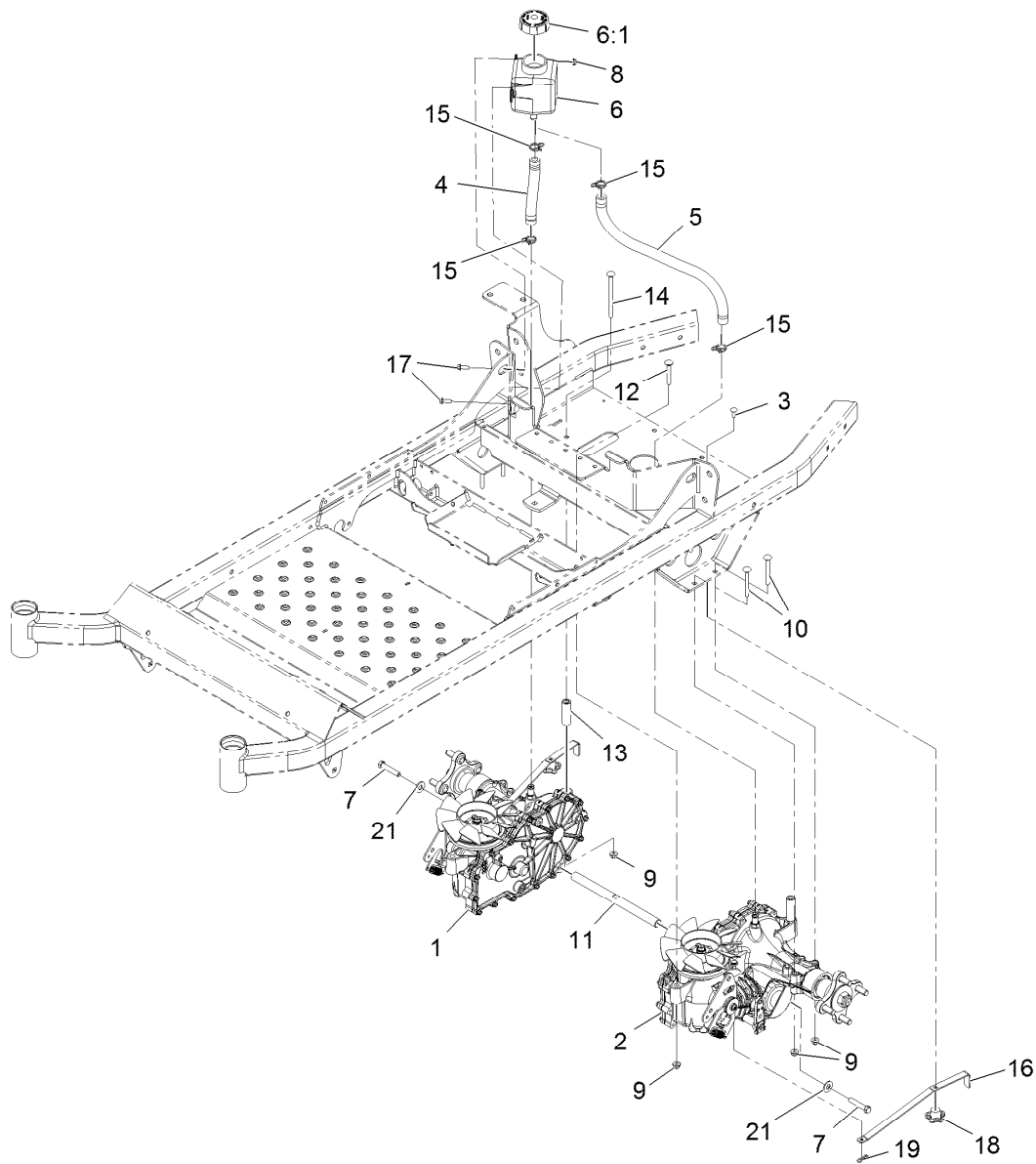

Hydraulic Assembly

Ref.	Part Number	Qty.	Description	Ref.	Part Number	Qty.	Description
1	116-3174	1	Transaxle ASM	11	116-6833	1	Shaft-Spacer
2	116-3173	1	Transaxle ASM	12	3230-7	2	Bolt-Carriage 5/16-18 X 2 1/4
3	3229-1	2	Bolt-Carriage 1/4-20 X 3/4	13	116-5809	2	Spacer-Hydro
4	116-5641	1	Hose-Hydraulic	14	3230-30	2	Bolt-Carriage 5/16-18 X 4 1/2
5	116-5642	1	Hose-Hydraulic	15	117-1193	4	Clamp-Hose
6	109-2250	1	Vent-Tank, Hydro	16	109-5395	2	Arm-Hydro Bypass
6:1	109-3320	1	Cap-Reservoir, HYD	17	32105-15	2	Screw-Machine 1/4-20 X 3/4
7	94-7972	2	Screw-HH W/Loctite ●	18	108-6402	2	Knob-Handle
8	104-7201	2	Nut-Nyloc 1/4-20 Flg	19	1-806003	2	Hairpin-Cotter
9	104-8300	8	Nut-Nyloc 5/16-18 Flg	21	3256-4	2	Washer-3/8 Std
10	3230-9	4	Bolt-Carriage 5/16-18 X 2 3/4				

● Use Pro-Lock, Nut Type (P/N 1-840022, .5ml tube) on threads.

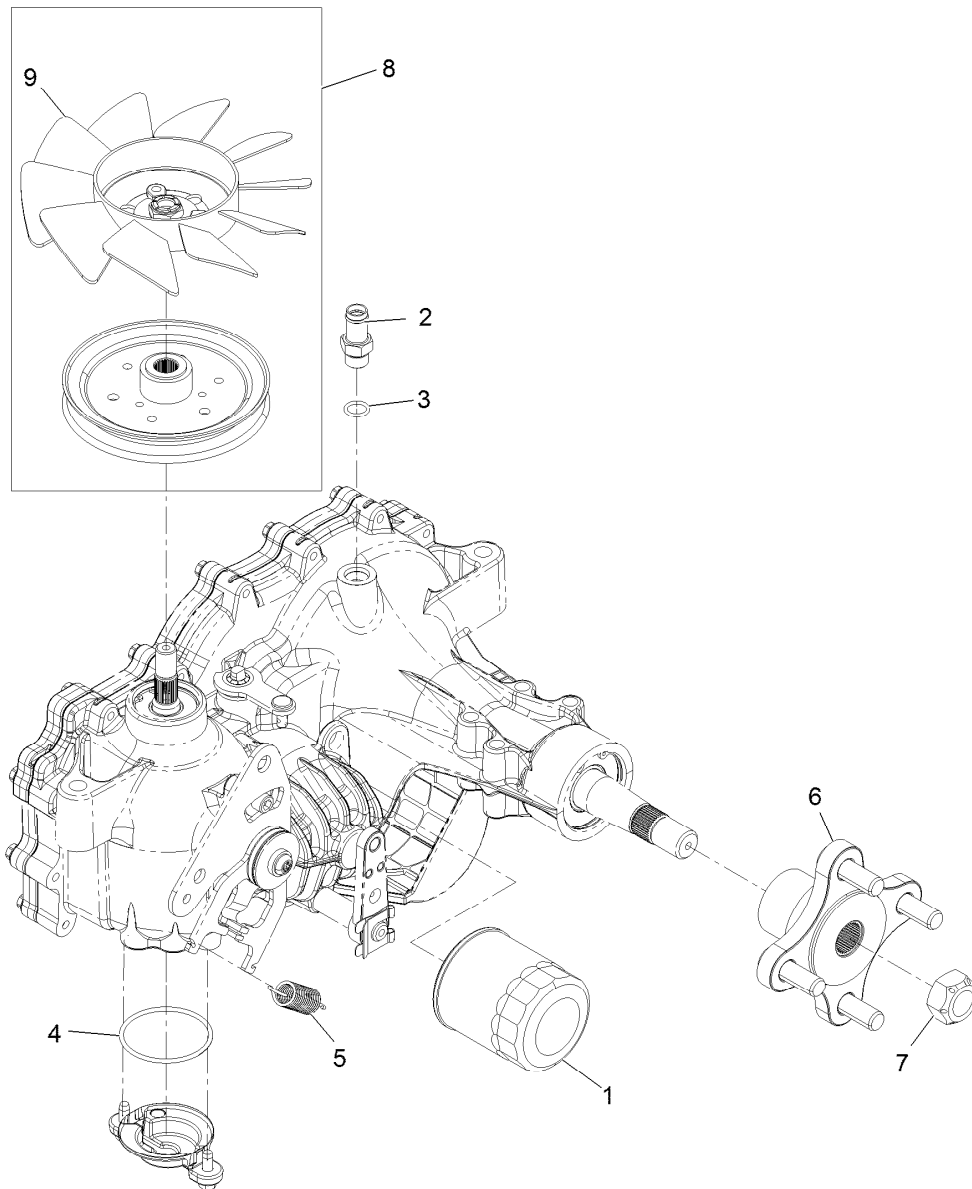

Transaxle Assembly

Ref.	Part Number	Qty.	Description
1	109-3321	1	Element-Oil Filter, HYD
2	109-3278	1	Adapter-Straight
3	237-42	1	O-Ring
4	109-3540	1	O-Ring-Seal
5	109-5592	1	Spring-Extension
6	109-5939	1	Hub Kit
7	109-3536	1	Nut-Hub
8	109-5938	1	Fan And Pulley Kit
9	114-8453	1	Fan-7.0
99	109-3537	1	Complete Seal Kit ●

● Not illustrated

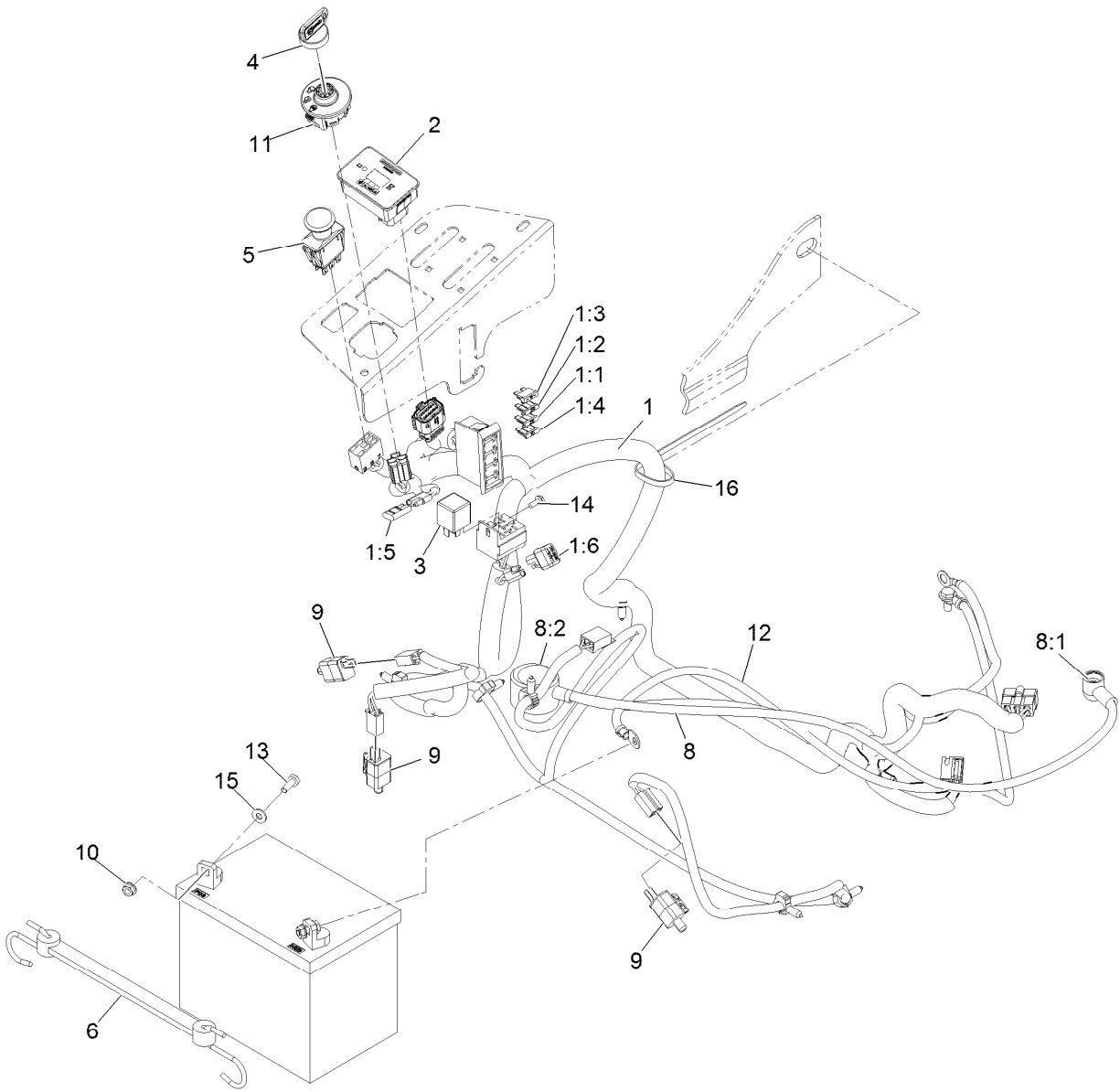

Electrical Assembly

<i>Ref.</i>	<i>Part Number</i>	<i>Qty.</i>	<i>Description</i>	<i>Ref.</i>	<i>Part Number</i>	<i>Qty.</i>	<i>Description</i>
1	116-4861	1	Harness, Wire ●	8	109-7621	1	Positive Battery Cable ASM
1:1	109102	1	Fuse-Blade, 25 Amp	8:1	1-543393	1	Insulator-Solenoid
1:2	1-816001	1	Fuse-Blade Type, 20 Amp	8:2	109-2407	1	Insulator-Battery
1:3	109355	1	Fuse-Blade, 15 Amp	9	110-6765	3	Switch-Single Pole No
1:4	218-578	1	Fuse-Blade, 10 Amp	10	32128-33	2	Nut-Whizlock 1/4-20
1:5	116-0053	1	Cap-Plug	11	117-2221	1	Switch-Ignition
1:6	103-3895	1	Diode-Tvs	12	117-7240	1	Cable-Battery, Negative
2	116-5609	1	Module ASM	13	321-4	2	Screw-HH 1/4-20 X 3/4
3	1-643275	1	Relay-12Vdc 40 Amp	14	32144-1	1	Screw-HWH #10-24 X 1/2 Taptite
4	103-2106	1	Key-Exmark Logo	15	3256-22	2	Washer-1/4 Sae
5	103-5221	1	Switch-PTO	16	1-303335	1	Tie-Cable 7 15/16 (Large)
6	104-2466	1	Holddown-Battery				

● Use dielectric grease on all unsealed connectors and terminals only. Do not apply in sealed connectors.

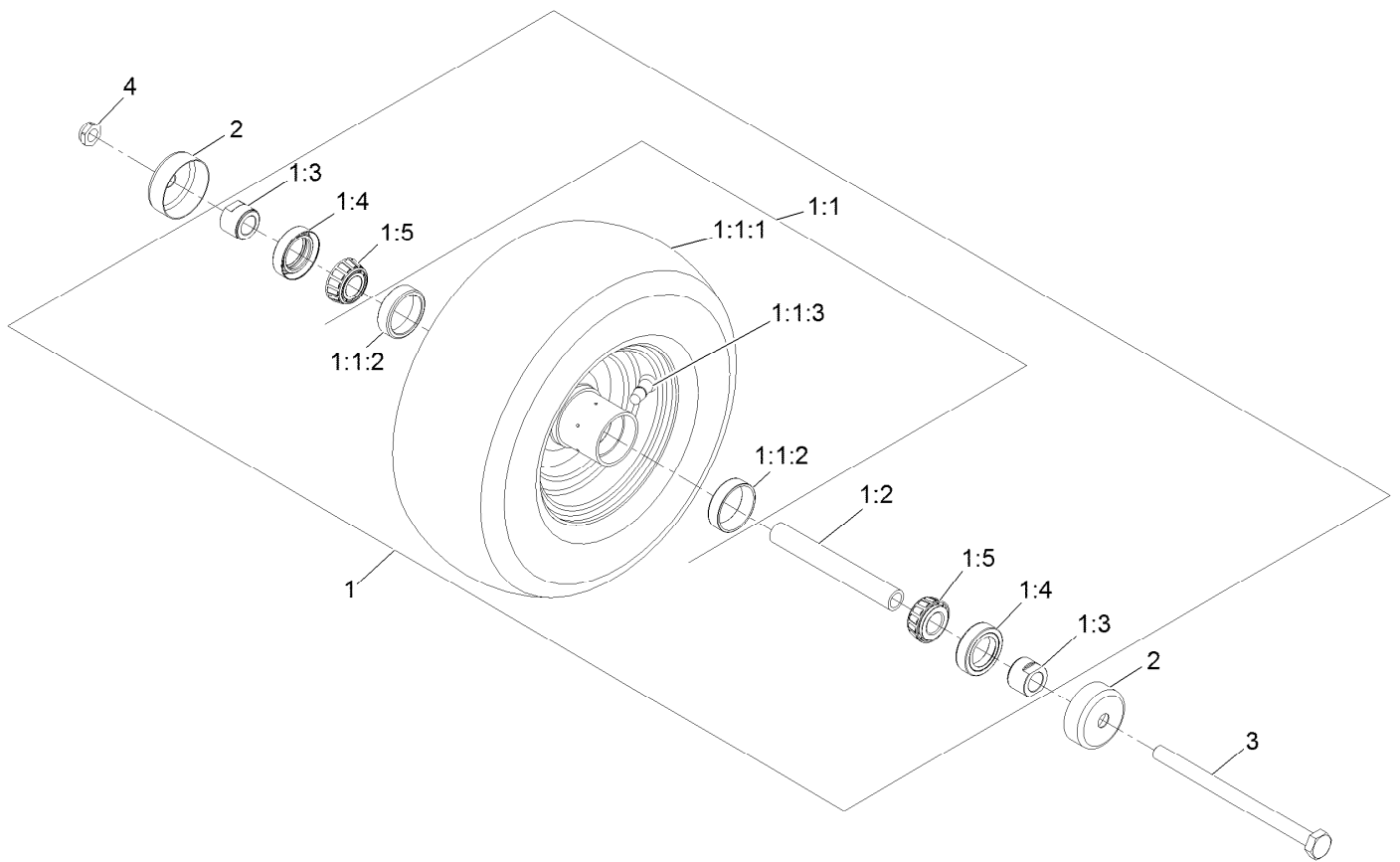

Caster Wheel Assembly No. 103-5189

Ref.	Part Number	Qty.	Description
1		1	ASM, Wheel And Brg 13X5.00-6 ●
1:1		1	ASM, Wheel And Tire 13X5.00-6 ●
1:1:1	1-633002	1	Tire
1:1:2	1-633584	2	Bearing-Cup
1:1:3	5108	1	Valve
1:2	103-3155	1	Axle, Caster
1:3	103-3051	2	Spacer-Nut ■
1:4	103-0063	2	Seal-Double Lip
1:5	1-633585	2	Bearing-Cone Tapered Roller
2	103-2768	2	Guard-Seal
3	325-36	1	Screw-HH 1/2-13 X 7 1/2
4	3296-45	1	Nut-Nyloc 1/2-13 Thin

● Not serviced separately

■ Use Pro-Lock, Nut Type (P/N 1-840022, .5ml tube) on threads.

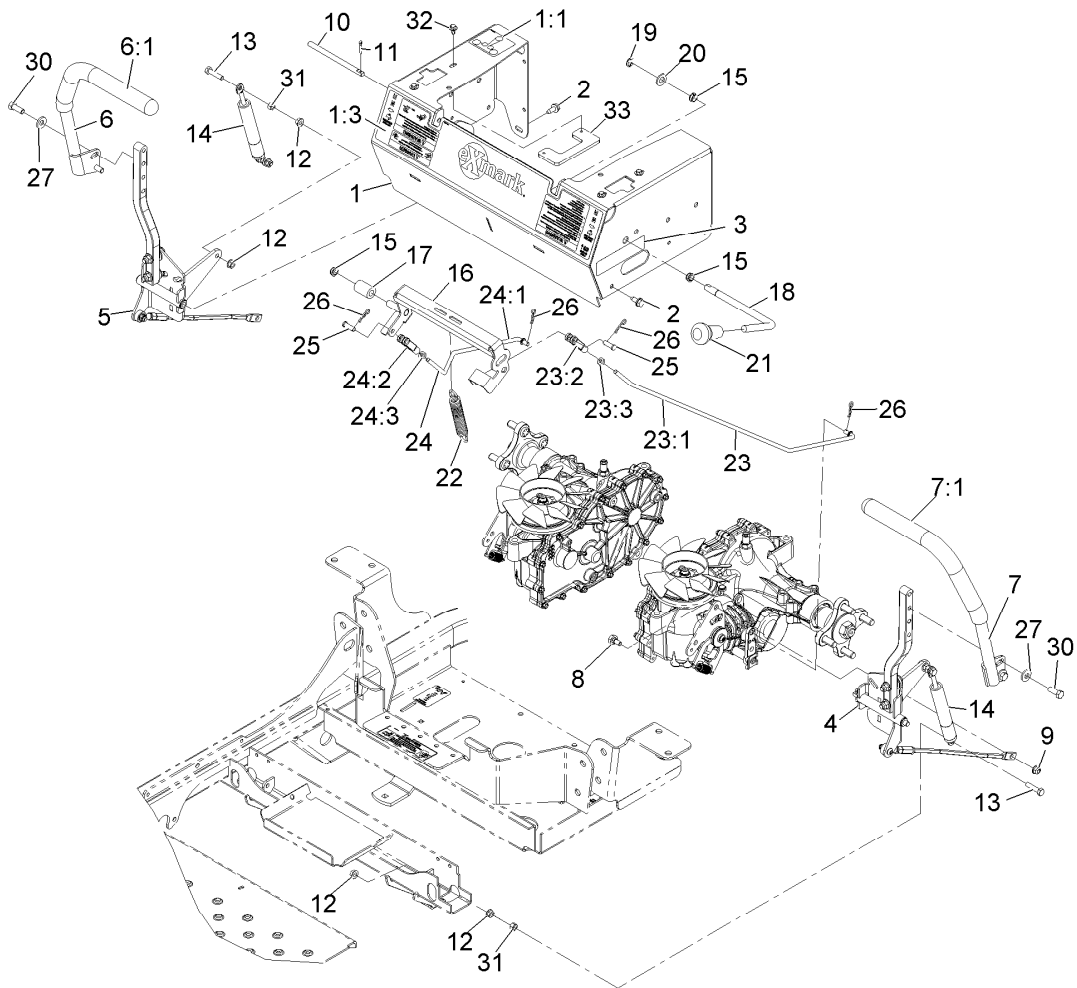

Motion Control Assembly

Ref.	Part Number	Qty.	Description	Ref.	Part Number	Qty.	Description
1	116-3188	1	ASM-Mot Ctrl Frm W/Dcl	16	116-6233	1	Wld-Brake Center Arm
1:1	109-6014	1	Decal-Belt Routing	17	109-5010	1	Spacer
1:3	116-4430	1	Decal-Front Panel	18	116-3155	1	Handle, Brake
2	32144-70	6	Screw-HWH 5/16-18 X 3/4 Tf	19	32120-47	1	Ring-Retaining
3	116-3884	1	Decal-S-Series	20	106-9888	1	Washer-Flat
4		1	Motion Control ASM-LH ●	21	106-7952	1	Knob
5		1	Motion Control ASM-RH ●	22	88-6130	1	Spring-Deck, Engagement
6	119-3486	1	RH Handle ASM	23	116-1165	1	Brake Linkage ASM-LH
6:1	108-6187	1	Grip	23:1	116-1167	1	Linkage, Brake LH
7	119-3485	1	LH Handle ASM	23:2	1-303105	1	Yoke-Adjustable
7:1	108-6187	1	Grip	23:3	3220-2	1	Nut-Jam 5/16-24
8	37-8771	2	Screw-Shoulder 5/16-18 X 5/8	24	116-1166	1	Brake Linkage ASM-RH
9	104-8300	2	Nut-Nyloc 5/16-18 Flg	24:1	116-1168	1	Linkage-Brake, RH
10	109-3705	2	Pin-Control Pivot	24:2	1-303105	1	Yoke-Adjustable
11	3272-10	2	Pin-Cotter 1/8 X 3/4	24:3	3220-2	1	Nut-Jam 5/16-24
12	32128-20	8	Nut-Whizlock 5/16-18	25	1-808280	2	Pin-Clevis 5/16 X 1 49/64
13	1-403180	4	Screw-HH 5/16-18 X 1 1/4 Sp	26	1-806003	4	Hairpin-Cotter
14	109-5957	2	Damper-Motion Control	27	98-5975	4	Washer-Spring Disc 3/8
15	116-1393	3	Bushing, Snap	30	323-6	4	Screw-HH 3/8-16 X 1
				31	3217-6	4	Nut-Hex 5/16-18
				32	46-8560	4	Screw-HHF 1/4-20 X 1/2
				33	109-6214	2	Stop-Motion Control

● Not serviced separately

Notes:

EXMARK® MAINTENANCE

MAXIMIZE THE PERFORMANCE OF YOUR EXMARK.

4-CYCLE PREMIUM ENGINE OIL

Part No. 116-3373

Both SAE 30 and SAE 10W-30 in one bottle.

Contains increased levels of zinc and phosphorus for better lubricity.

No Viscosity Index Improvers that tend to shear down in high heat.

Synthetic formulation.

Gas & Diesel compatible.

Anti-corrosion additives.

API 'SL' and JASO rated with wet clutch compatibility for other machines.

PREMIUM HYDRO OIL

Part No. 109-9828

Commercial quality for tough, high-heat conditions.

Designed specifically for zero-turn mower hydraulic systems.

Superior shear resistance under heavy loads.

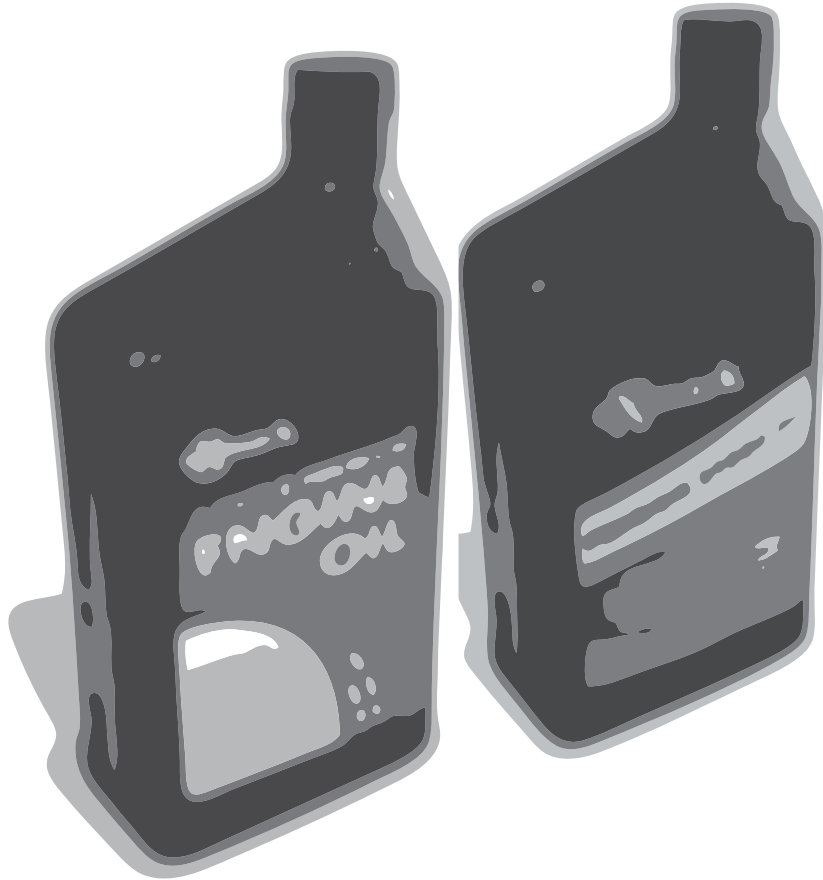

Available from your local Exmark dealer. Find your closest dealer at exmark.com

EXMARK ACCESSORIES AND OPTIONS*

MID-MOUNT RIDING ACCESSORIES AND OPTIONS

CUSTOM RIDE SEAT SUSPENSION SYSTEM	OPERATOR CONTROLLED DISCHARGE
FULL SUSPENSION SEAT	SUN SHADE
DECK LIFT ASSIST KIT	TRASH CONTAINER
HITCH KIT	TURF STRIPER
LIGHT KIT	ULTRA VAC COLLECTION SYSTEM
12V POWER PORT	ULTRA VAC QUICK DISPOSAL SYSTEM
MICRO-MULCH SYSTEM	

OUT-FRONT RIDING ACCESSORIES AND OPTIONS

CUSTOM RIDE SEAT SUSPENSION SYSTEM	SNOW BLADE
DUAL-TAIL WHEEL	SNOWBLOWER
FLOOR PAN EXTENDER	SUN SHADE
HITCH KIT	TRASH CONTAINER
LIGHT KIT	ULTRA VAC COLLECTION SYSTEM
MICRO-MULCH SYSTEM	ULTRA VAC QUICK DISPOSAL SYSTEM
ROLL OVER PROTECTION SYSTEM (ROPS)	WEATHER CAB

WALK-BEHIND ACCESSORIES AND OPTIONS

GRASS CATCHER	TURF STRIPER
MICRO-MULCH SYSTEM	STANDON

*Some accessories and options not available for some models.

Place Model No. and Serial No.
Label Here (Included in the Literature
Pack) or Fill in Below

Model No. _____

Serial No. _____

Date Purchased _____

Engine Model No. and Spec. No. _____

Engine Serial No. (E/No) _____

© 2012 Exmark Mfg. Co., Inc.
Industrial Park Box 808
Beatrice, NE 68310
All Rights Reserved

Part No. 4501-002 Rev. B
(402) 223-6300
Fax (402) 223-5489
Printed in the USA.

