

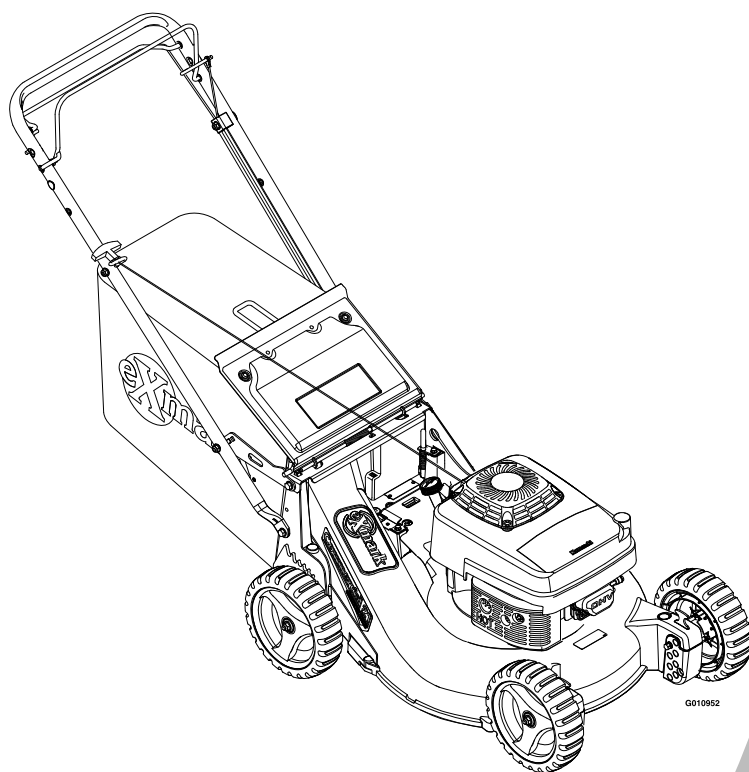

COMMERCIAL 21

Model No. ECSKA21—Serial No. 31300000 and Up

Picture below may not reflect actual product.



Parts Manual

Part No. 4501-532 Rev. A

Ordering Replacement Parts

To order replacement parts, please supply the part number, the quantity, and the description of each part desired.

Understanding Reference Numbers

Each identified part in an illustration has a reference number. The reference number for a part also appears in the parts list, along with other information about the part.

This catalog uses two special reference number formats, one to indicate parts in a service assembly and another to indicate the quantity of a given part in an illustration.

Service Assembly Reference Numbers

Parts in service assemblies have reference numbers in the form a:b. The a represents the reference number of the entire service assembly and the b represents a sequential number unique to each part within the service assembly.

For example, a wheel assembly might be identified by reference number 6, the tire by 6:1, the valve by 6:2, and the wheel by 6:3. When you order the assembly identified by reference number 6, you receive all parts identified by reference numbers 6:1, 6:2, and 6:3. However, you may also order any part individually. Reference numbers of this type appear in illustration and in parts lists.

Reference Numbers Indicating Quantity

In an illustration, if a reference number indicates more than one part, the reference number has the form nX y. The n represents the quantity of the part, the X is the multiplication symbol, and the y represents the reference number.

For example, in an illustration, the reference number 2X 37 means that two of the parts identified by reference number 37 are indicated.

List of Abbreviations

AR: as required	HJ: hex jam	PRH: phillips round head
ASM: assembly	HLH: hex lag head	PTH: phillips truss head
BBC: blade brake control	HOC: height-of-cut	PTO: power-take-off
BHTF: button head thread forming	HSBH: hex socket button head	RH: right hand
CARR: carriage	HSFH: hex socket flat head	ROPS: roll-over protection system
CCW: counter clockwise	HSH: hex socket head	RRB: rear roller brush
CW: clockwise	HWH: hex washer head	SFH: slotted fillister head
DEG: degrees	HWHTF: hex washer head thread forming	SHH: slotted hex head
DPA: Dual Point Adjustment	HYD: hydraulic	SHWH: slotted hex washer head
ECM: electronic control module	LH: left hand	SPH: slotted pan head
EXT: external	LP: Liquefied Petroleum Gas	SQH: square head
FH: flat head	LPG: Liquefied Petroleum Gas	SRH: slotted round head
GA: gauge	NI: nylon insert	STD: standard
HD: heavy-duty	NPTF: national pipe thread fine	TAP: self tapping
HF: hex flange	PFH: phillips flat head	TTH: torx truss head
HH: hex head	PPH: phillips pan head	
HHF: hex head flange	PPHTF: phillips pan head thread forming	
HHFTF: hex head flange thread forming		

Touch Up Paint

Exmark black touch up spray paint – gloss black.

Exmark red touch up paint (spray paint – P/N 1-850337 - .6 oz liquid bottle – P/N 103-9140).



If your Exmark dealer does not have the Exmark part in stock, Exmark will get the parts to the dealer the next business day or the part will be FREE Guaranteed!! (Some restrictions apply. See your participating Exmark Dealer for details.)

Contents

Deck and Wheel Assembly 4
Gear Case Assembly - 116-0103..... 5
Handle Assembly 6
Bag and Door Assembly 7
Blade Assembly 8
Engine Assembly 9

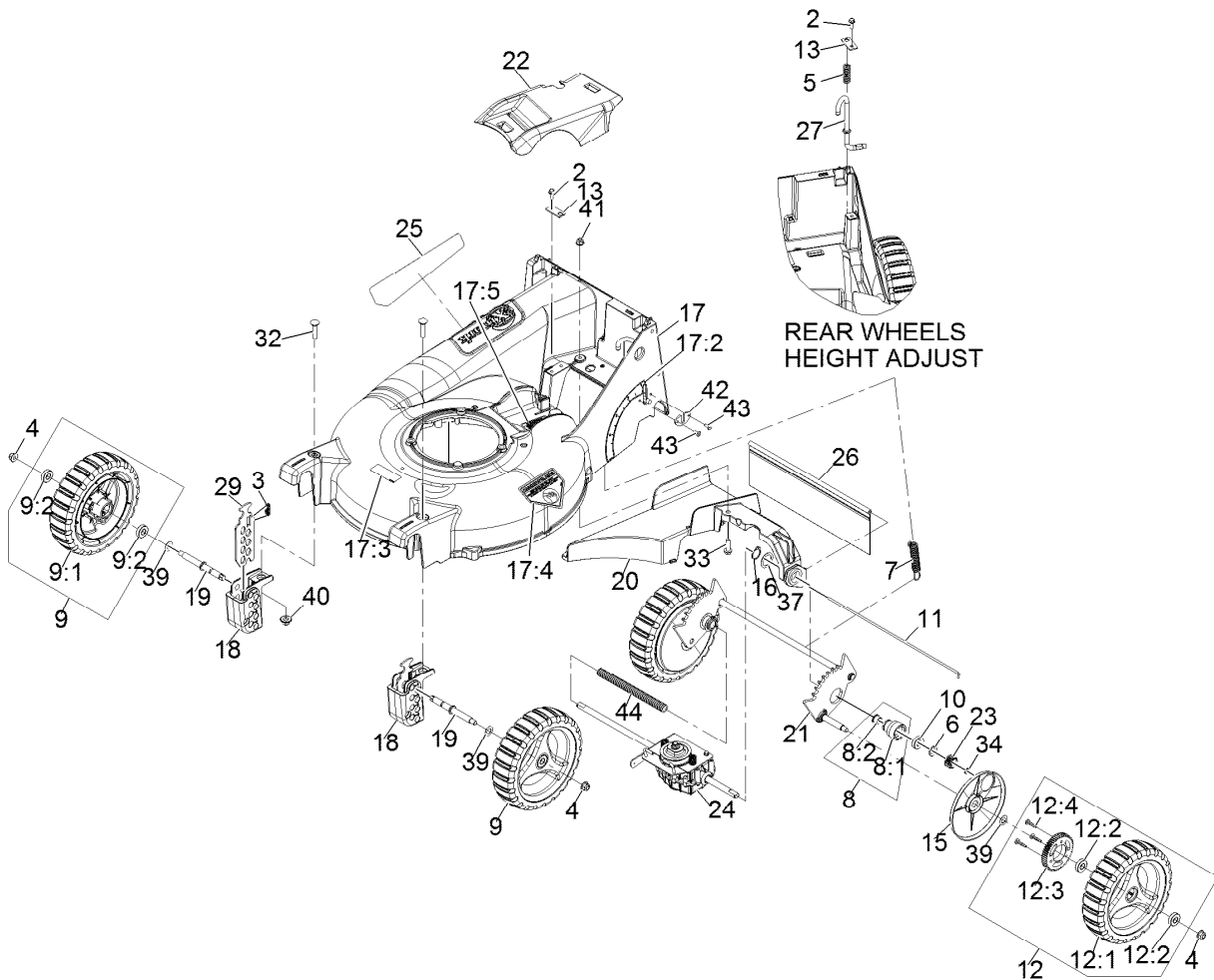

Deck and Wheel Assembly

Ref.	Part Number	Qty.	Description	Ref.	Part Number	Qty.	Description
2	32144-85	2	Screw-HWH 1/4-20 X .62	17:5	109-9317	1	Decal-Cover Missing
3	109-7258	2	Spring-Compression	18	109-9302	2	Block,Front Quadrant
4	104-8301	4	Nut-Nyloc 3/8-16 Flg	19	116-0994	2	Axle-Wheel
5	109-7694	1	Spring-Compression	20	116-9646-01	1	Bracket-Transmission And Chute
6	108-5059	2	Spacer-Bushing	21	109-9312	1	Wld,Rear Axle P21
7	109-7692	1	Spring-Extension	22	109-9324	1	Cover,Belt
8	116-6172	2	Housing ASM	23	110-9417	2	Gear-Pinion, 15T
8:1	116-6171	1	Housing-Bearing	24	116-0103	1	ASM,Transmission W/Bracket
8:2	116-4279	1	Bearing-Flange	25	116-4362	1	Decal-Comm 21 S-Series
9	109-8016	2	Wheel And Tire ASM	26	116-0252	1	Shield-Trailing P21
9:1	109-8033	1	9-Inch Wheel ASM	27	116-0329	1	Rod-Height Adj P21
9:2	109-8020	2	Bearing-Ball	29	109-9292	2	Plate, Front Height
10	109-8020	2	Bearing-Ball	32	109-8449	2	Bolt-Carriage 3/8-16 X 1 1/2 Tf
11	109-8025	1	Rod,Shield	33	32144-49	1	Screw-HWH 5/16-18 1 1/4 Tf
12	109-8032	2	ASM,Rear Wheel 9"	34	32151-61	2	Ring-Retaining
12:1	109-8033	1	9-Inch Wheel ASM	37	74-1810	2	Washer
12:2	109-8020	2	Bearing-Ball	39	36-4780	4	Washer
12:3	109-7264	1	Gear	40	109-6658	2	Nut-Nyloc 3/8-16 Flg
12:4	27-6260	3	Screw-Drive	41	104-8300	1	Nut-Nyloc 5/16-18 Flg
13	109-8441	2	Bracket,Mount	42	116-2221	1	Plate,Wear
15	109-9287	2	Cover,Gear	43	114439	2	Rivet
16	32151-36	2	Ring-Retaining	44	117-5260	1	Cover-Shaft, Drive
17	116-2006	1	Deck W/Decals				
17:2	116-1922	1	Decal-Height Of Cut				
17:3	68-7410	1	Decal-Blade				
17:4	94-8072	1	Decal-Danger				

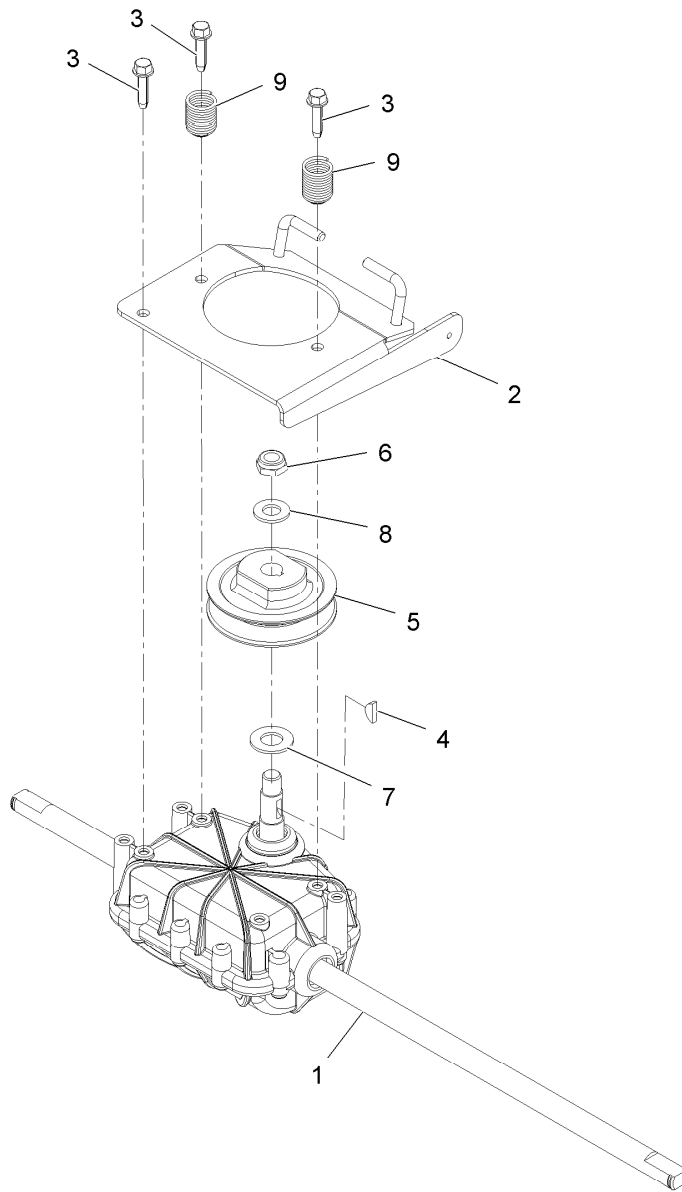

Gear Case Assembly - 116-0103

<i>Ref.</i>	<i>Part Number</i>	<i>Qty.</i>	<i>Description</i>
1	109-9290	1	Transmission-HD, 4.5/1
2	116-3539-03	1	Transmission Plate ASM
3	27-0220	3	Screw-Special
4	3257-1	1	Key-Woodruff 1/8 X 1/2
5	39-6740	1	Pulley
6	3296-5	1	Nut-Nyloc 3/8-24 Thin
7	36-4792	1	Washer-Thrust
8	3256-45	1	Washer-Flat
9	116-1438	2	Spring, Compression

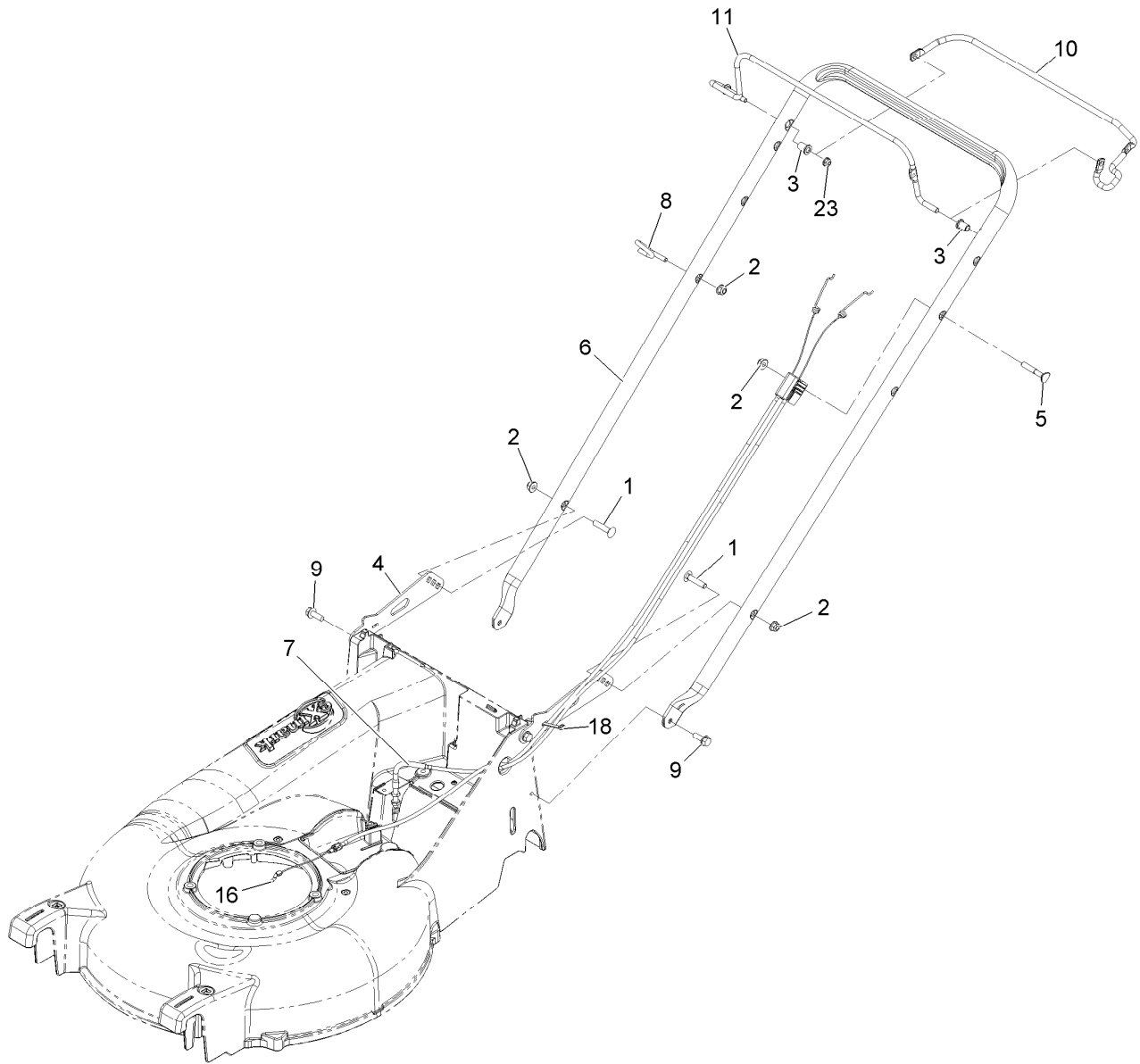

Handle Assembly

Ref.	Part Number	Qty.	Description
1	33-5790	2	Bolt-Carriage 5/16-18 X 1 1/2
2	104-8300	4	Nut-Nyloc 5/16-18 Flg
3	116-1478	2	Bushing-Handlebar
4	109-9323-03	2	Bracket,Handlebar
5	112-8876	1	Bolt-Carriage 5/16-18 X 2
6	116-0119-03	1	Handlebar-P21
7	116-0904	1	Cable-Drive
8	116-1056	1	Guide,Rope
9	32144-41	4	Screw-HWH 3/8-16 X 7/8 Taptite
10	116-7797	1	Bail-Drive
11	116-2252	1	Bail,OpC/BBC
16	116-0905	1	Cable-Zone Kawasaki
18	614249	1	Tie-Cable
23	104-7201	1	Nut-Nyloc 1/4-20 Flg

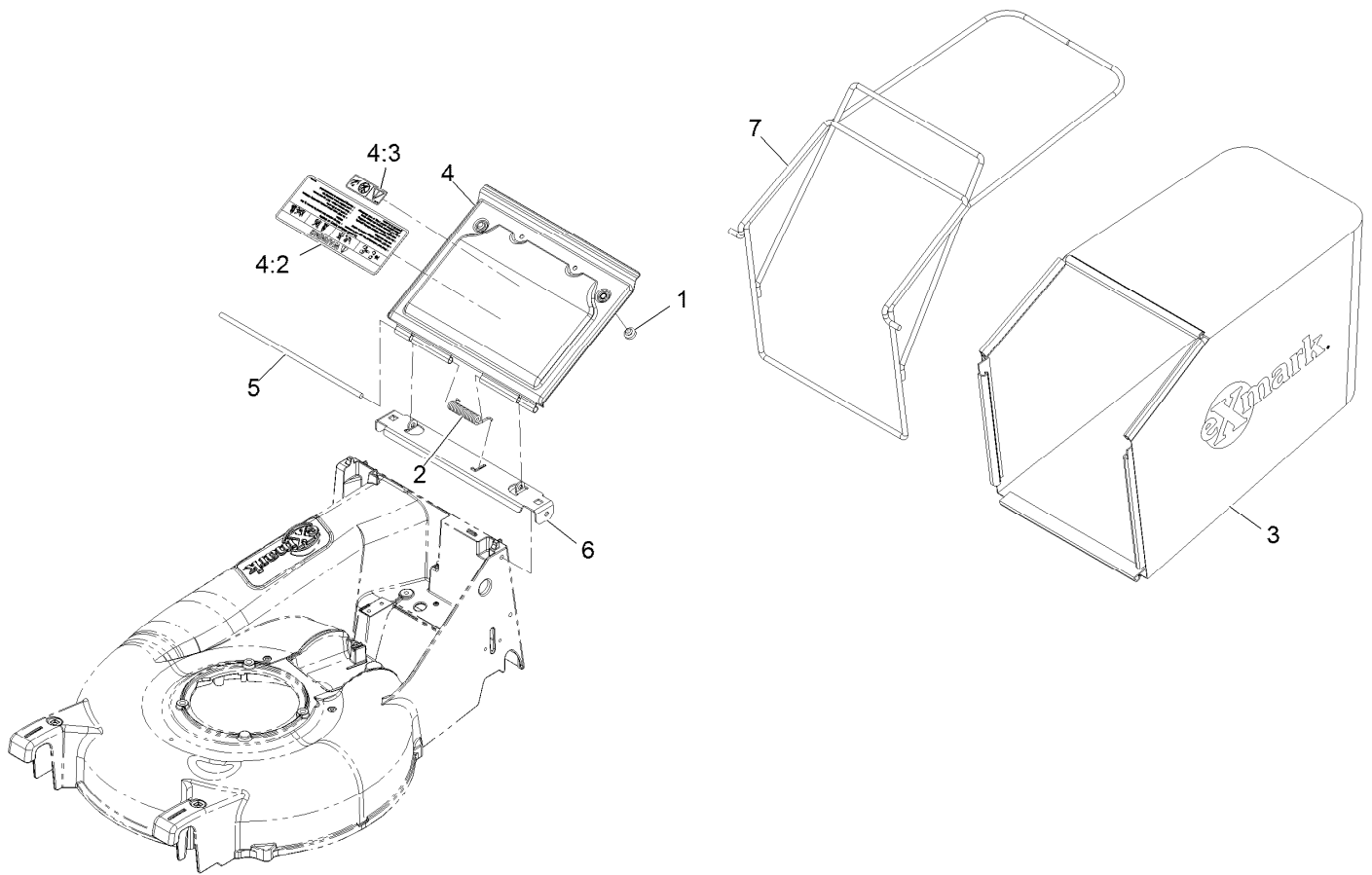

Bag and Door Assembly

Ref.	Part Number	Qty.	Description
1	1-513658	2	Bumper
2	109-7696	1	Spring-Torsion,Cover
3	109-7294	1	Bag,Grass P21
4	116-2007	1	Door W/Decal
4:2	116-2737	1	Decal-Warning Door Lg
4:3	121-1449	1	Decal-Warning, Block
5	109-9321	1	Rod,Door Pivot
6	109-9322-03	1	Bracket-Door P21
7	109-9325-03	1	Wld,Bag Frame

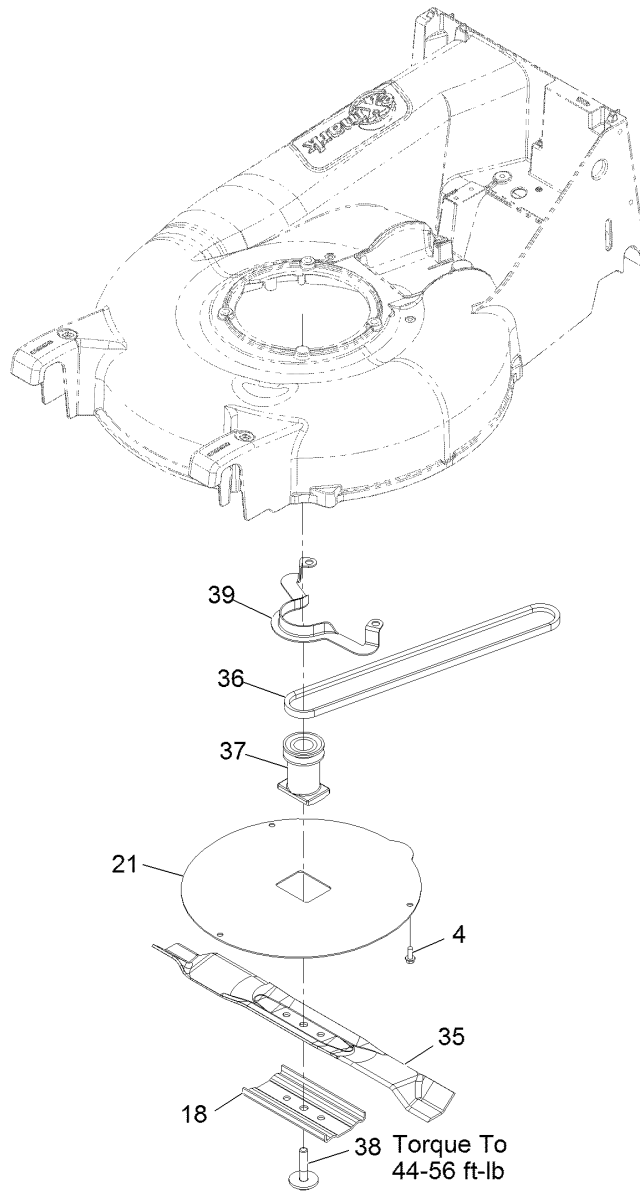

Blade Assembly

Ref.	Part Number	Qty.	Description
4	32144-85	3	Screw-HWH 1/4-20 X .62
18	108-3766-03	1	Support-Blade
21	116-3503-03	1	Cover-As
35	116-4500	1	Blade-Medium Lift, 20.5
36	109-7299	1	Belt,3L P21 Drive
37	109-7257	1	Blade-Adapter
38	116-0005	1	Bolt-Blade, Sem
39	108-8110-03	1	Guide-Belt

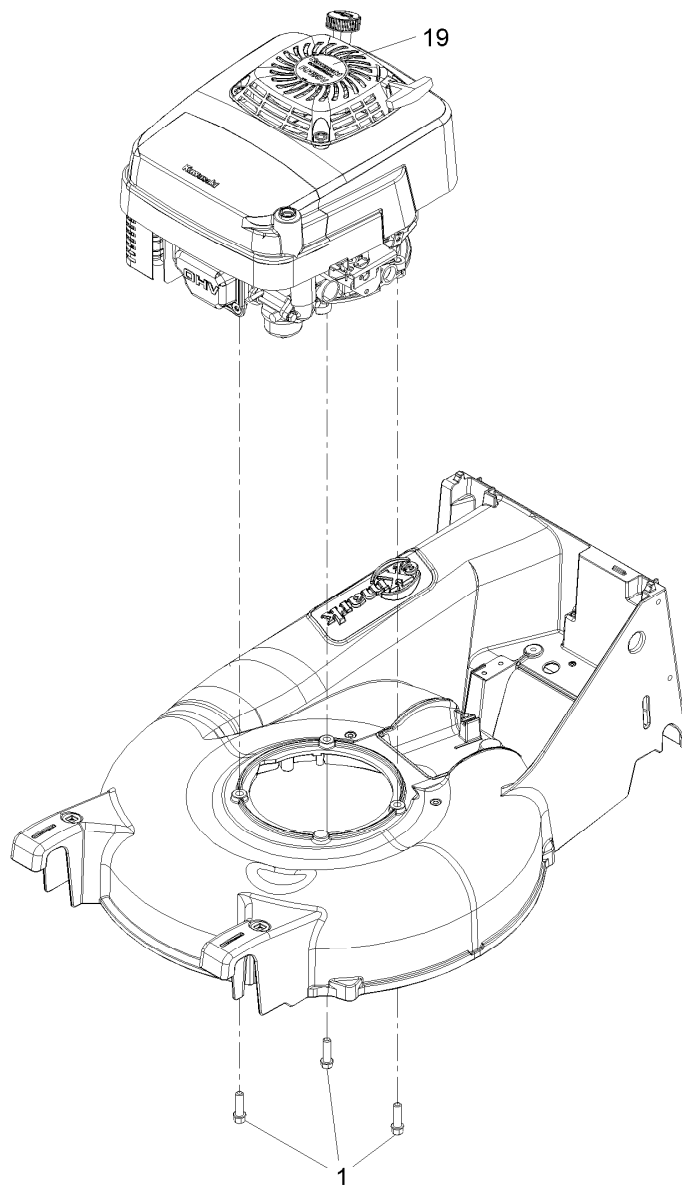

Engine Assembly

<i>Ref.</i>	<i>Part Number</i>	<i>Qty.</i>	<i>Description</i>
1	95-1727	3	Screw-Tapite
19	107-4201	1	Decal-Recoil

Notes:

Notes:

EXMARK ACCESSORIES AND OPTIONS*

MID-MOUNT RIDING ACCESSORIES AND OPTIONS

CUSTOM RIDE SEAT SUSPENSION SYSTEM	OPERATOR CONTROLLED DISCHARGE
FULL SUSPENSION SEAT	SUN SHADE
DECK LIFT ASSIST KIT	TRASH CONTAINER
HITCH KIT	TURF STRIPER
LIGHT KIT	ULTRA VAC COLLECTION SYSTEM
12V POWER PORT	ULTRA VAC QUICK DISPOSAL SYSTEM
MICRO-MULCH SYSTEM	

OUT-FRONT RIDING ACCESSORIES AND OPTIONS

CUSTOM RIDE SEAT SUSPENSION SYSTEM	SNOW BLADE
DUAL-TAIL WHEEL	SNOWBLOWER
FLOOR PAN EXTENDER	SUN SHADE
HITCH KIT	TRASH CONTAINER
LIGHT KIT	ULTRA VAC COLLECTION SYSTEM
MICRO-MULCH SYSTEM	ULTRA VAC QUICK DISPOSAL SYSTEM
ROLL OVER PROTECTION SYSTEM (ROPS)	WEATHER CAB

WALK-BEHIND ACCESSORIES AND OPTIONS

GRASS CATCHER	TURF STRIPER
MICRO-MULCH SYSTEM	STANDON

*Some accessories and options not available for some models.

Place Model No. and Serial No.
Label Here (Included in the Literature
Pack) or Fill in Below

Model No. _____

Serial No. _____

Date Purchased _____

Engine Model No. and Spec. No. _____

Engine Serial No. (E/No) _____

© 2013 Exmark Mfg. Co., Inc.
Industrial Park Box 808
Beatrice, NE 68310
All Rights Reserved

Part No. 4501-532 Rev. A
(402) 223-6300
Fax (402) 223-5489
Printed in the USA.

