

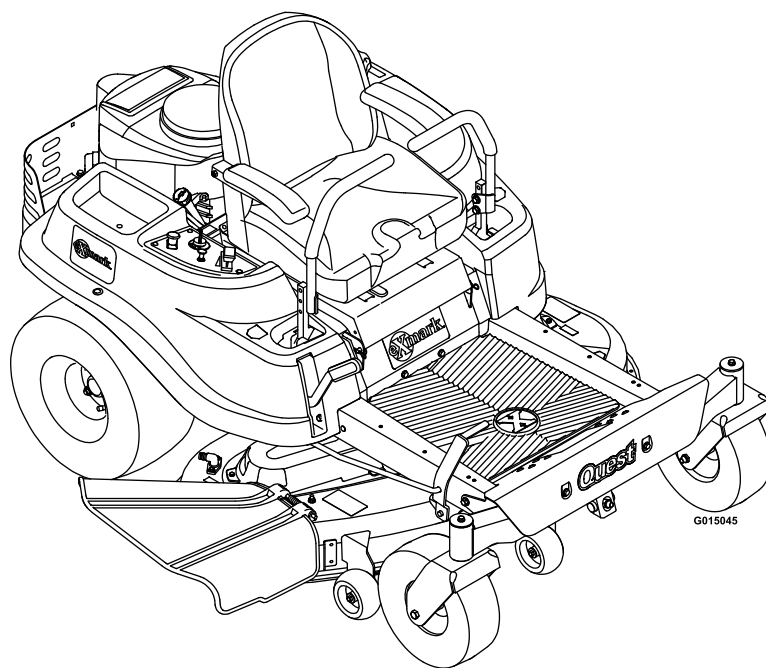

# QUEST®

Model No. QTS691KA502—Serial No. 31300000 and Up

Picture below may not reflect actual product.



# Parts Manual

Part No. 4501-557 Rev. B

# Ordering Replacement Parts

To order replacement parts, please supply the part number, the quantity, and the description of each part desired.

## Understanding Reference Numbers

Each identified part in an illustration has a reference number. The reference number for a part also appears in the parts list, along with other information about the part.

This catalog uses two special reference number formats, one to indicate parts in a service assembly and another to indicate the quantity of a given part in an illustration.

## Service Assembly Reference Numbers

Parts in service assemblies have reference numbers in the form a:b. The a represents the reference number of the entire service assembly and the b represents a sequential number unique to each part within the service assembly.

For example, a wheel assembly might be identified by reference number 6, the tire by 6:1, the valve by 6:2, and the wheel by 6:3. When you order the assembly identified by reference number 6, you receive all parts identified by reference numbers 6:1, 6:2, and 6:3. However, you may also order any part individually. Reference numbers of this type appear in illustration and in parts lists.

## Reference Numbers Indicating Quantity

In an illustration, if a reference number indicates more than one part, the reference number has the form nX y. The n represents the quantity of the part, the X is the multiplication symbol, and the y represents the reference number.

For example, in an illustration, the reference number 2X 37 means that two of the parts identified by reference number 37 are indicated.

# List of Abbreviations

<b>AR:</b> as required	<b>HJ:</b> hex jam	<b>PRH:</b> phillips round head
<b>ASM:</b> assembly	<b>HLH:</b> hex lag head	<b>PTH:</b> phillips truss head
<b>BBC:</b> blade brake control	<b>HOC:</b> height-of-cut	<b>PTO:</b> power-take-off
<b>BHTF:</b> button head thread forming	<b>HSBH:</b> hex socket button head	<b>RH:</b> right hand
<b>CARR:</b> carriage	<b>HSFH:</b> hex socket flat head	<b>ROPS:</b> roll-over protection system
<b>CCW:</b> counter clockwise	<b>HSH:</b> hex socket head	<b>RRB:</b> rear roller brush
<b>CW:</b> clockwise	<b>HWH:</b> hex washer head	<b>SFH:</b> slotted fillister head
<b>DEG:</b> degrees	<b>HWHTF:</b> hex washer head thread forming	<b>SHH:</b> slotted hex head
<b>DPA:</b> Dual Point Adjustment	<b>HYD:</b> hydraulic	<b>SHWH:</b> slotted hex washer head
<b>ECM:</b> electronic control module	<b>LH:</b> left hand	<b>SPH:</b> slotted pan head
<b>EXT:</b> external	<b>LP:</b> Liquefied Petroleum Gas	<b>SQH:</b> square head
<b>FH:</b> flat head	<b>LPG:</b> Liquefied Petroleum Gas	<b>SRH:</b> slotted round head
<b>GA:</b> gauge	<b>NI:</b> nylon insert	<b>STD:</b> standard
<b>HD:</b> heavy-duty	<b>NPTF:</b> national pipe thread fine	<b>TAP:</b> self tapping
<b>HF:</b> hex flange	<b>PFH:</b> phillips flat head	<b>TTH:</b> torx truss head
<b>HH:</b> hex head	<b>PPH:</b> phillips pan head	
<b>HHF:</b> hex head flange	<b>PPHTF:</b> phillips pan head thread forming	
<b>HHFTF:</b> hex head flange thread forming		

# Touch Up Paint

Exmark black touch up spray paint – gloss black.

Exmark red touch up paint (spray paint – P/N 1-850337 - .6 oz liquid bottle – P/N 103-9140).



If your Exmark dealer does not have the Exmark part in stock, Exmark will get the parts to the dealer the next business day or the part will be FREE Guaranteed!! (Some restrictions apply. See your participating Exmark Dealer for details.)

## Contents

Deck Assembly .....	4
50 Inch Deck Decal Assembly No. 121-2968 .....	5
50 Inch Deck Belt, Spindle and Blade Assembly .....	6
Main Frame and Front Axle Assembly .....	7
13 Inch Wheel and Tire Assembly .....	8
Deck Lift Assembly .....	9
Motion Control Assembly .....	10
Seat Assembly .....	11
Seat W/Track Assembly No. 121-5670 .....	12
Armrest Kit Assembly No. 110-5719 .....	13
Engine and Muffler Assembly .....	14
Clutch Assembly .....	15
Controls and Fuel Tank .....	16
Hydro Transaxle Drive and Rear Wheel Assembly .....	17
Left Hand Hydro Transaxle Assembly No. 119-3360 .....	18
Right Hand Hydro Transaxle Assembly No. 119-3361 .....	20
Belt and Pulley Assembly .....	22
Fuel Delivery Assembly .....	23
Electrical Assembly .....	24

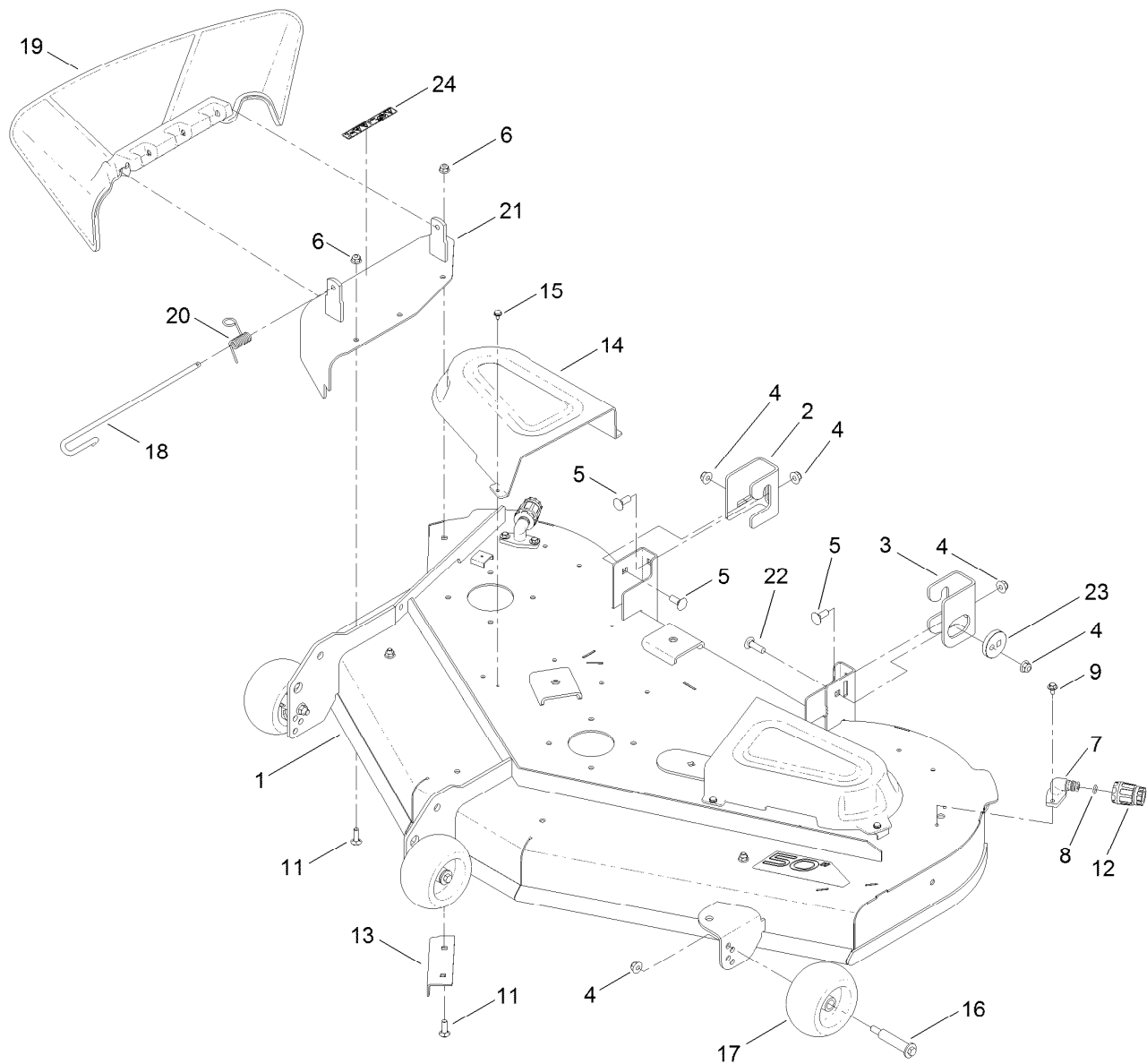

## Deck Assembly

Ref.	Part Number	Qty.	Description	Ref.	Part Number	Qty.	Description
1	121-2968	1	50" Deck And Decal ASM (Exmark Service)	14	108-7890	2	Cover-Belt
2	119-3494	1	Bracket-Hanger, RH	15	32144-1	6	Screw-HWH #10-24 X 1/2 Taptite
3	121-0797	1	Bracket-Hanger, LH	16	112-3977	3	Bolt-HH Shoulder 3/8-16 X 3.79
4	104-8301	7	Nut-Nyloc 3/8-16 Flg	17	1-603299	3	Roller-Scalp, Anti
5	3231-2	3	Bolt-Carriage 3/8-16 X 1	18	109-8854	1	Pin-Chute
6	104-8300	4	Nut-Nyloc 5/16-18 Flg	19	121-0739	1	Deflector-Discharge
7	95-2747	2	Fitting-Washout	20	121-2983	1	Spring-Torsion
8	46-6290	2	O-Ring	21	120-7925-01	1	Discharge Cover ASM
9	46-8560	4	Screw-HHF 1/4-20 X 1/2	22	3231-28	1	Bolt-Carriage 3/8-16 X 1 1/4
11	3230-22	4	Bolt-Carriage 5/16-18 X 1 Sp	23	112-3980	1	Eccentric
12	95-3270	1	Connector-Hose	24	93-7009	1	Decal-Danger, Deflector
13	120-7951-03	1	Baffle-Cutoff				

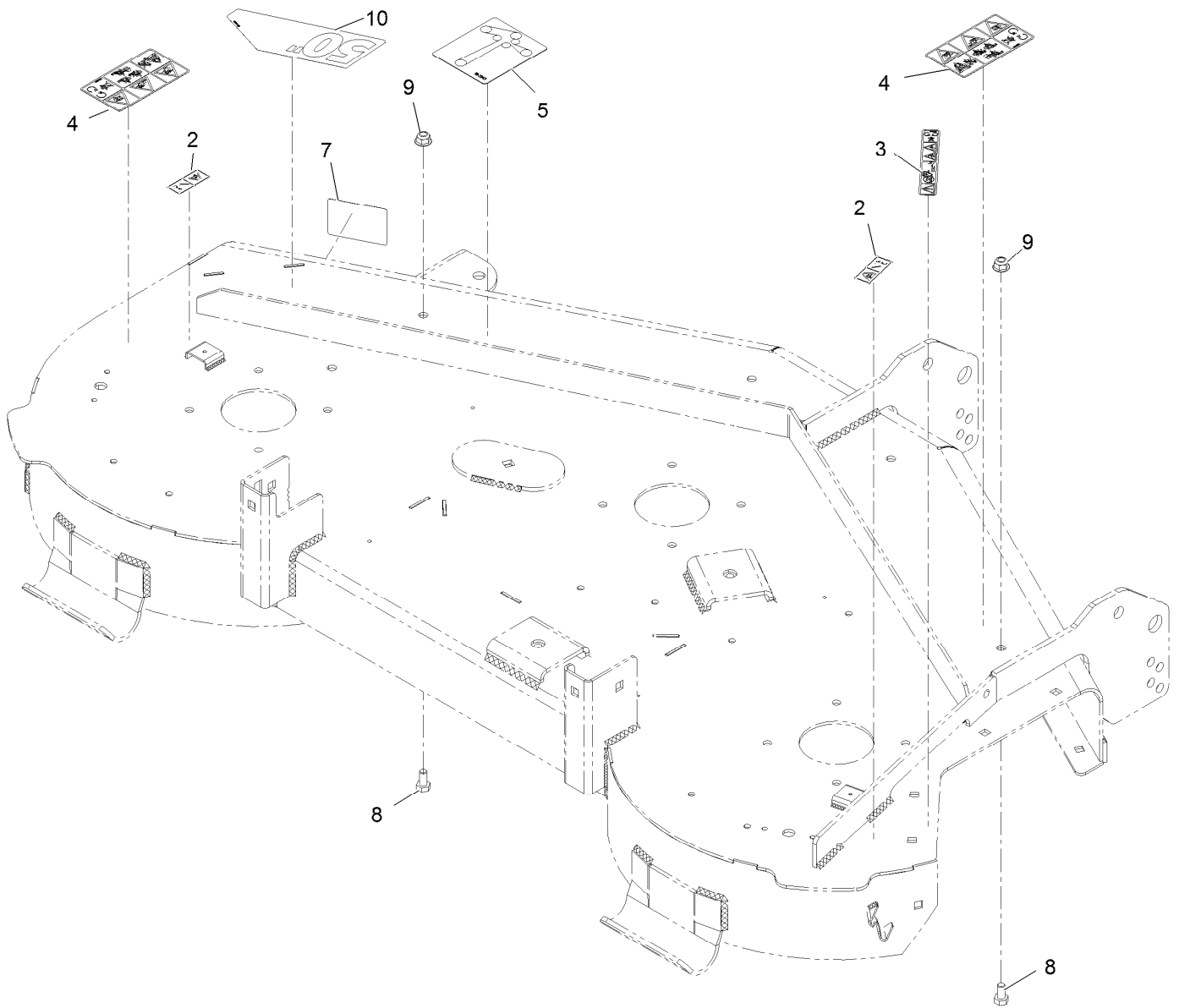

## 50 Inch Deck Decal Assembly No. 121-2968

Ref.	Part Number	Qty.	Description
2	114-1606	2	Decal-Danger
3	93-7009	1	Decal-Danger, Deflector
4	110-6691	2	Decal-Danger
5	99-3943	1	Decal-Routing, Belt
7	112-9840	1	Decal-Scalp, Anti
8	322-2	2	Screw-HH 5/16-18 X 5/8
9	104-8300	2	Nut-Nyloc 5/16-18 Flg
10	121-5653	1	Decal-Deck

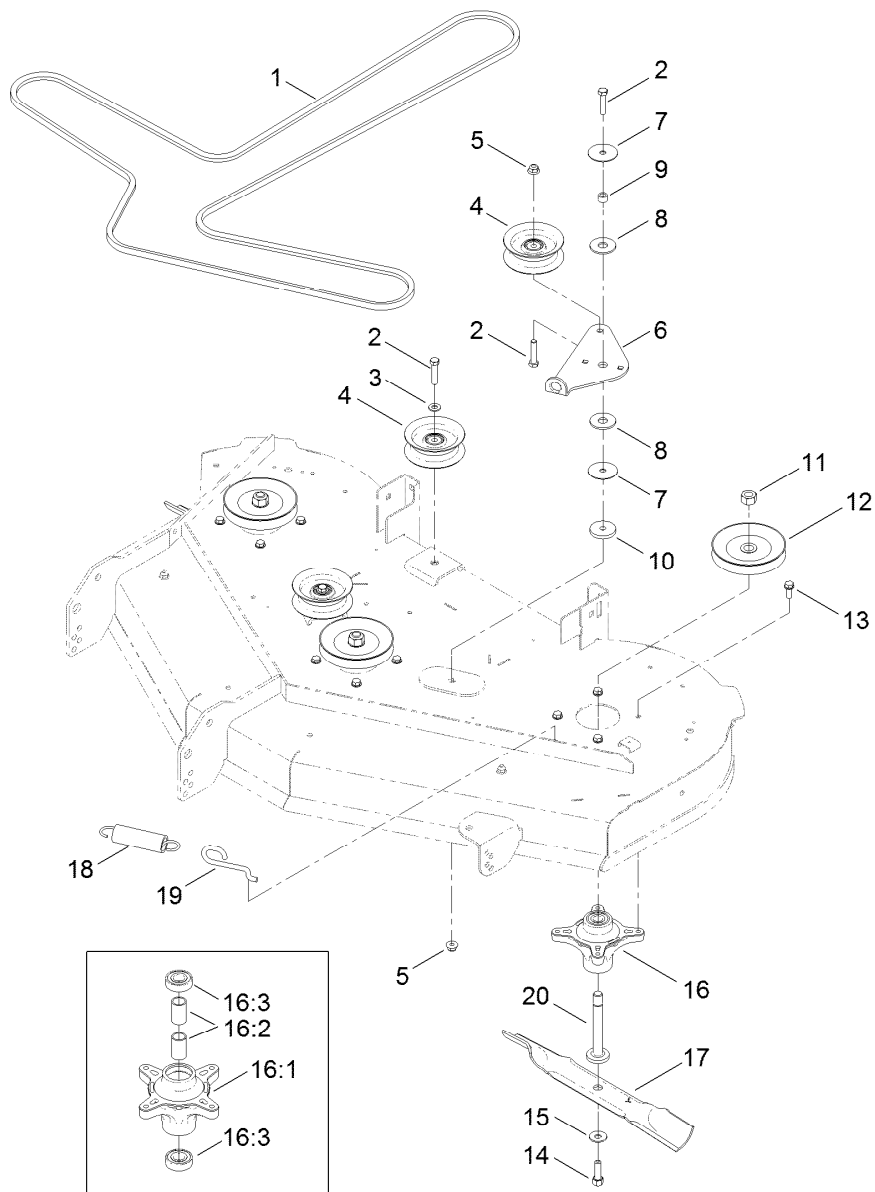

## 50 Inch Deck Belt, Spindle and Blade Assembly

<i>Ref.</i>	<i>Part Number</i>	<i>Qty.</i>	<i>Description</i>	<i>Ref.</i>	<i>Part Number</i>	<i>Qty.</i>	<i>Description</i>
1	119-8820	1	V-Belt	13	32144-41	12	Screw-Taptite
2	323-9	4	Screw-HH	14	26-0671	3	Screw-HH
3	3256-24	2	Washer-Flat	15	3290-465	3	Washer-Belleville
4	106-2175	3	Pulley-Idler, Flat	16	121-0751	3	Spindle ASM
5	104-8301	2	Nut-Flange, NI	16:1	117-7267	1	Spindle
6	114-8540	1	Arm-Idler	16:2	120-7935	2	Spacer
7	120-2229	2	Washer-Idler Pivot	16:3	100-1048	2	Bearing-Ball
8	114-0463	2	Washer-Friction, Composite	17	115-5059-03	3	Blade-Hi Lift, 17.50 Inch
9	115-4986	1	Spacer	18	1-603414	1	Spring-Extension
10	110-9981	1	Washer-Plain	19	112-3973	1	Hook-Return, Spring
11	3219-6	3	Nut-Hex	20	117-7268	3	Shaft-Spindle
12	125-5575	3	Pulley				

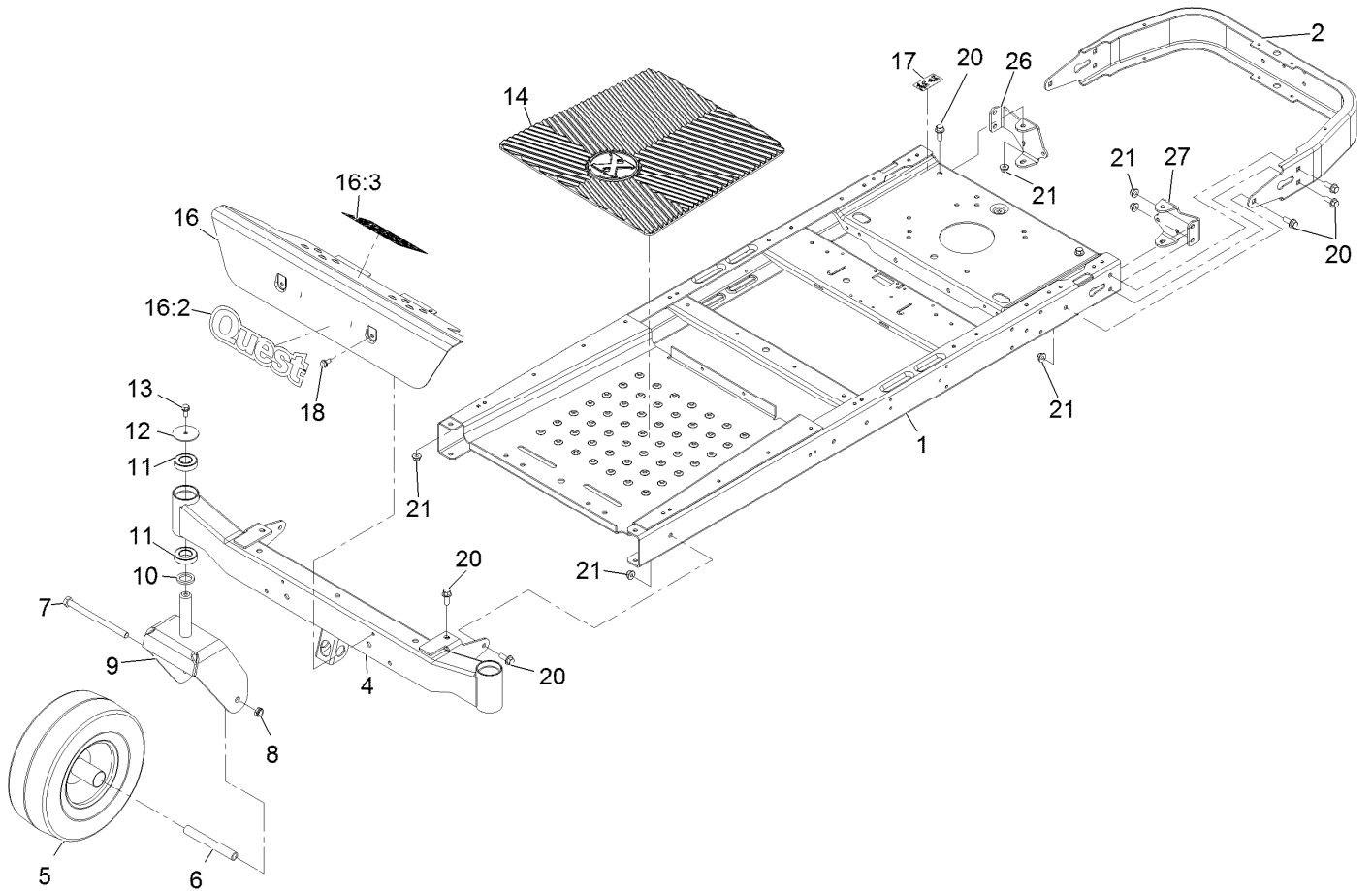

## Main Frame and Front Axle Assembly

<i>Ref.</i>	<i>Part Number</i>	<i>Qty.</i>	<i>Description</i>	<i>Ref.</i>	<i>Part Number</i>	<i>Qty.</i>	<i>Description</i>
1	120-7963-01	1	Frame ASM	13	3234-47	2	Screw-HH Flg 5/16-18 X 3/4
2	117-7415-01	1	Bumper-Rear (Wide)	14	120-5456	1	Mat-Floor
4	121-5683-01	1	Front Axle ASM (Wide)	16	125-0073	1	Footrest Service ASM
5	119-3473	2	13 Inch Wheel And Tire ASM	16:2	116-4218	1	Decal
6	119-3475	2	Spanner	16:3	120-2239	1	Decal-Danger
7	325-37	2	Screw-HH	17	121-2989	2	Decal-Bypass
8	3296-45	2	Nut-Nyloc 1/2-13 Thin	18	32144-70	2	Screw-HWH 5/16-18 X 3/4 Tf
9	119-3349-01	2	Fork-Caster, Wide	20	3234-42	14	Screw HHF 3/8-16 X 1
10	117-7394	2	Washer-Thrust	21	104-8301	14	Nut-Nyloc 3/8-16 Flg
11	109-3678	4	Bearing-Ball	26	121-0737-01	1	Mount-Hydro, Rear RH
12	119-8915	2	Washer	27	121-0738-01	1	Mount-Hydro, Rear LH

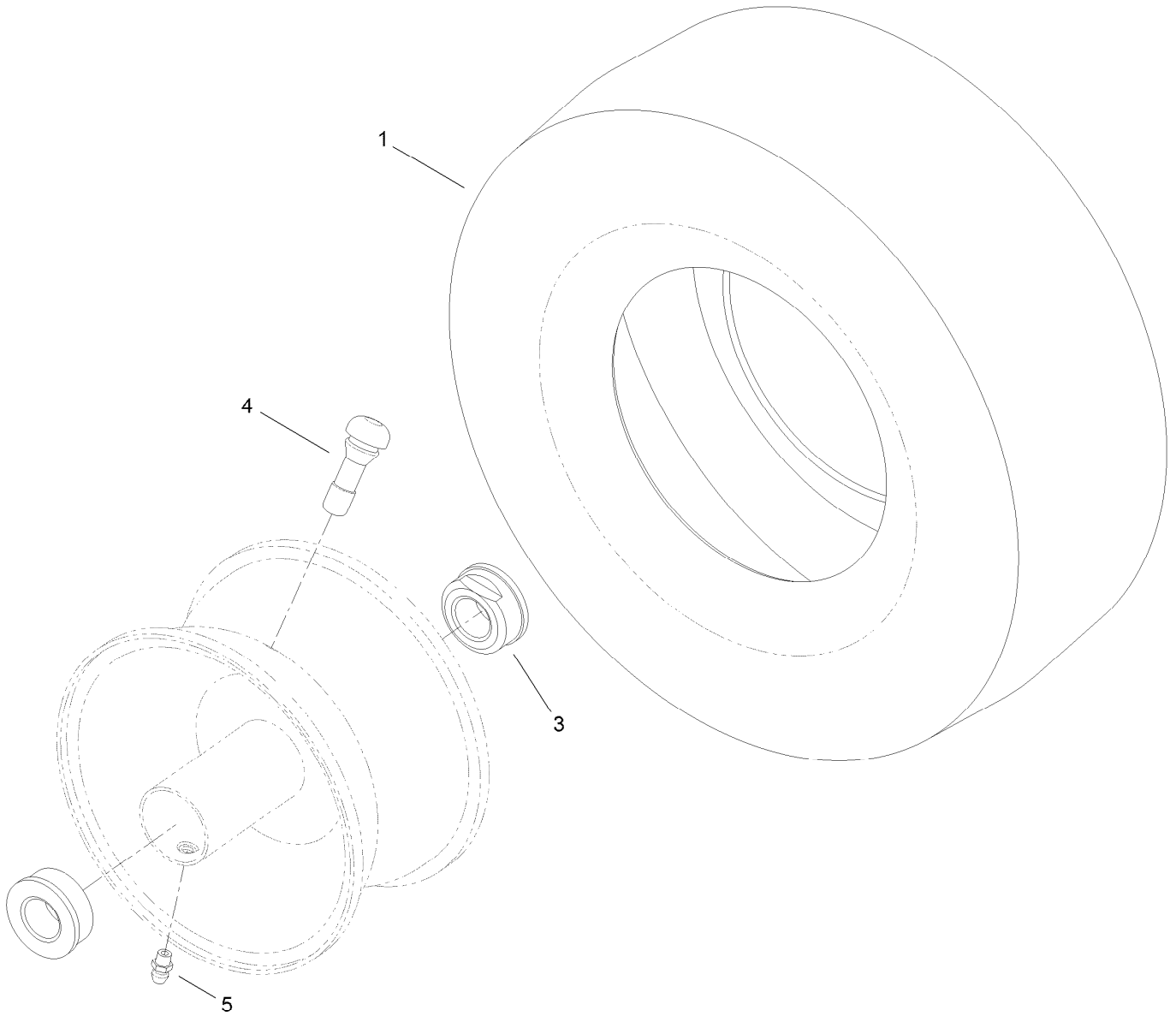

## 13 Inch Wheel and Tire Assembly

<i>Ref.</i>	<i>Part Number</i>	<i>Qty.</i>	<i>Description</i>
1	119-3471	1	Tire-13 Inch
3	114-1640	2	Bushing-Flange
4	232-27	1	Stem-Valve
5	302-5	1	Fitting-Grease



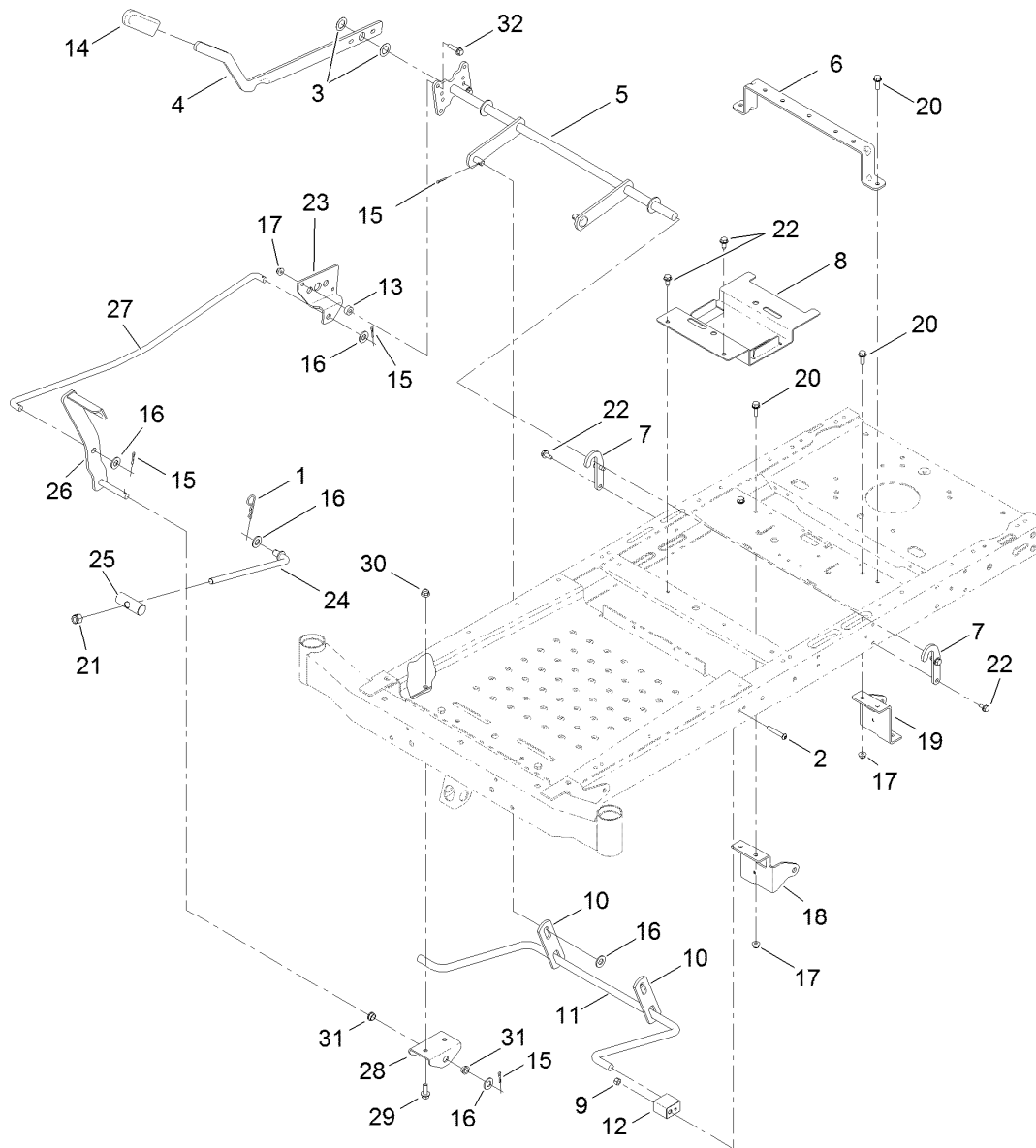

## Deck Lift Assembly

Ref.	Part Number	Qty.	Description	Ref.	Part Number	Qty.	Description
1	1-806005	1	Hairpin-Cotter	18	120-7936-01	1	Mount-Hydro, Front Right
2	120-5499	2	Screw-HSBH	19	120-7937-01	1	Mount-Hydro, Front Left
3	3-6498	2	Washer-Thrust	20	3234-29	4	Screw-HH Flg 5/16-18 X 1
4	119-3427-03	1	Lever-Lift	21	3296-19	1	Nut-Nyloc 1/2-20
5	119-3424-03	1	Lift-Deck	22	32144-70	6	Screw-HWH 5/16-18 X 3/4 Tf
6	117-7337-03	1	Brace-Seat, Rear	23	120-2275	1	Plate-Footlift
7	119-8875	2	Bracket-Lift	24	104-8047	1	Rod-Trunion
8	119-3406-03	1	Bracket-Battery	25	119-8810	1	Pin-Pivot
9	3296-29	2	Nut-Nyloc 5/16-18	26	120-2276-01	1	Pedal ASM
10	108-7840	2	Link-Lift	27	120-2242	1	Rod-Footlift
11	119-3347	1	Arm-Lift, Rear	28	120-2294-01	1	Bracket-Footlift
12	108-7845	2	Block-Pivot	29	3234-42	2	Screw HHF 3/8-16 X 1
13	121-1759	2	Spacer	30	104-8301	2	Nut-Nyloc 3/8-16 Flg
14	1-633268	1	Grip-Lever	31	256-156	2	Bushing-Flange
15	3272-10	5	Pin-Cotter 1/8 X 3/4	32	3234-36	2	Screw-HH Flg 5/16-18 X 1 1/4
16	3256-26	6	Washer-1/2 Sae				
17	104-8300	6	Nut-Nyloc 5/16-18 Flg				

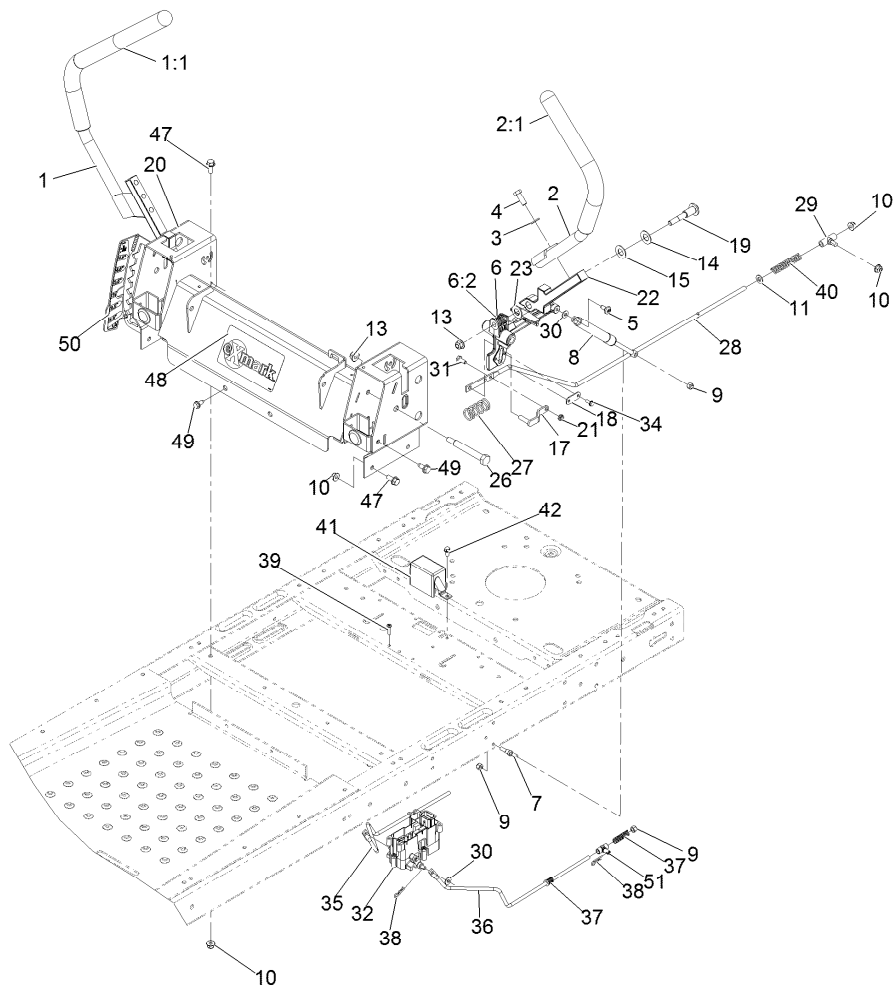

## Motion Control Assembly

Ref.	Part Number	Qty.	Description	Ref.	Part Number	Qty.	Description
1	121-0731	1	Handle-Control, RH	26	115-5099	2	Bolt-Pivot
1:1	121-0726	1	Grip	27	119-8876	2	Spring-Return
2	121-0730	1	Handle-Control, LH	28	117-5388	2	Rod-Hydro
2:1	121-0726	1	Grip	29	119-8842	2	Mount-Rod, Hydro
3	3256-24	4	Washer-3/8 Sae	30	119-8952	4	Washer
4	323-6	4	Screw-HH 3/8-16 X 1	31	321-3	2	Screw-HH 1/4-20 X 5/8
5	120-7950	2	Screw-Shoulder	32	121-3017	1	Brake Control Module ASM
6	119-3470	2	Actuator Arm ASM	34	32144-1	4	Screw-HWH #10-24 X 1/2 Taptite
6:2	256-156	2	Bushing-Flange	35	119-8811	1	Rod-Brake, RH
7	110-6810	2	Stud-Damper	36	119-8812	1	Rod-Brake, LH
8	103-2913	2	Damper-Control, Motion	37	121-5654	4	Spring-Compression
9	3296-42	6	Nut-Nyloc 1/4-20	38	3290-307	4	Pin-Hair
10	104-8300	10	Nut-Nyloc 5/16-18 Flg	39	32144-36	4	Screw-PPH
11	3256-23	2	Washer-5/16 Sae	40	1-603807	2	Spring
13	104-8301	4	Nut-Nyloc 3/8-16 Flg	41	119-8859	1	Cover-Brake
14	119-8925	2	Washer-Belleville	42	32144-4	1	Screw-HWH 1/4-20 X 1/2 Taptite
15	117-1240	2	Washer	47	3234-47	6	Screw-HH Flg 5/16-18 X 3/4
17	119-3303	2	Pin-Rod, Hydro	48	116-4219	1	Decal
18	119-8948	2	Plate-Stop, Hydro	49	32144-70	4	Screw-HWH 5/16-18 X 3/4 Tf
19	117-1198	2	Bolt-Pivot	50	119-8870	1	Decal-HOC
20	125-5474-03	1	Wide Control Box	51	119-8857	2	Mount-Pivot
21	3296-56	2	Nut-Nyloc 1/4-20 Thin				
22	115-5098-05	2	Lever-Control				
23	120-2273	2	Washer-Nylon				

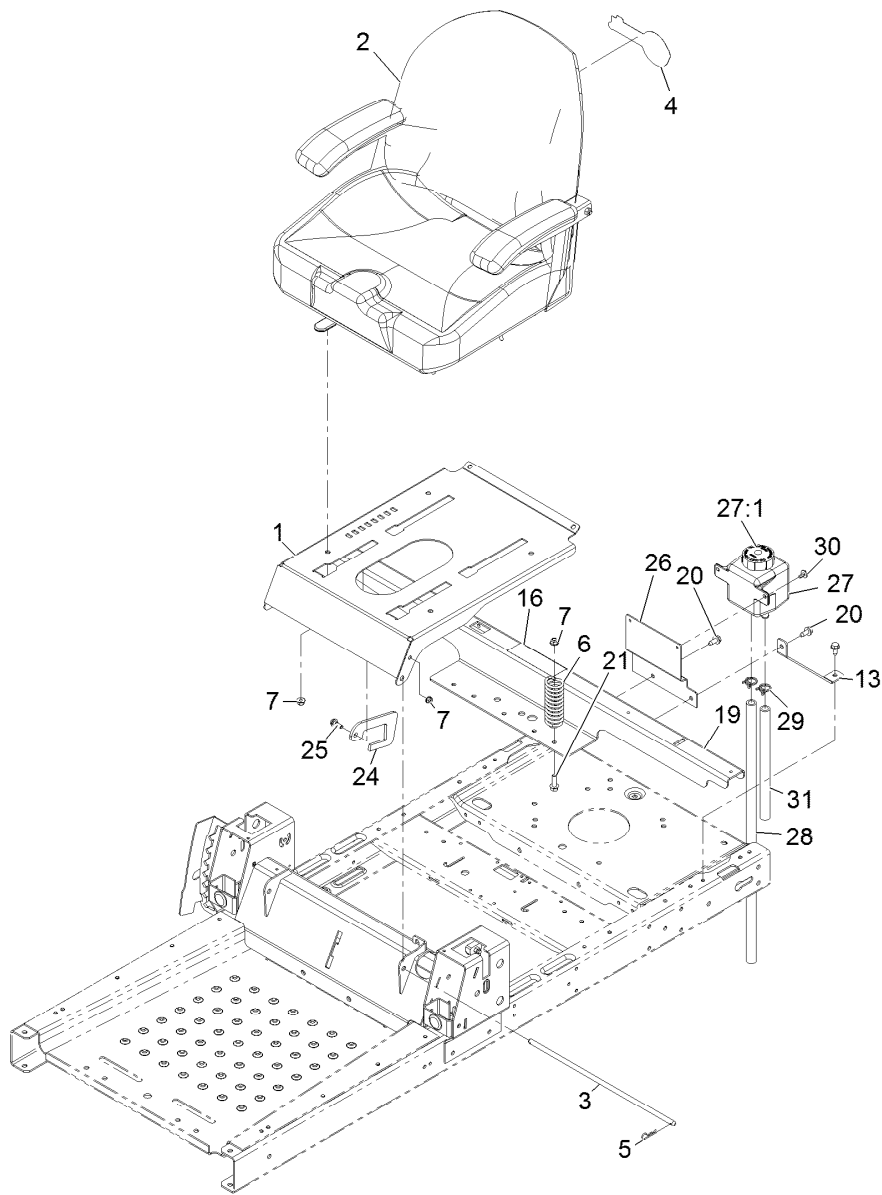

## Seat Assembly

<i>Ref.</i>	<i>Part Number</i>	<i>Qty.</i>	<i>Description</i>	<i>Ref.</i>	<i>Part Number</i>	<i>Qty.</i>	<i>Description</i>
1	119-3390-03	1	Pan-Seat	21	3234-29	3	Screw-HHF
2	121-5670	1	Seat ASM	24	120-5512	1	Stop-Seat
3	115-4966	1	Rod-Stop	25	116-2670	1	Screw-Shoulder
4	120-5464	1	Decal	26	120-7970-03	1	Mount-Tank
5	3290-250	2	Pin-Hair	27	109-2250	1	Vent-Tank, Hydro
6	92-7054	3	Spring-Compression	27:1	109-3320	1	Cap-Reservoir, HYD
7	104-8300	5	Nut-Flange, NI	28	121-2951	1	Hose-Overflow
13	119-3431-03	2	Support-Tank, Rear	29	117-1193	4	Clamp-Hose
16	106-8717	1	Decal-Service	30	46-8560	2	Screw-HHFTF
19	119-3414-03	1	Support-Pod	31	121-2952	1	Hose-Overflow
20	32144-70	5	Screw-HWHTF				

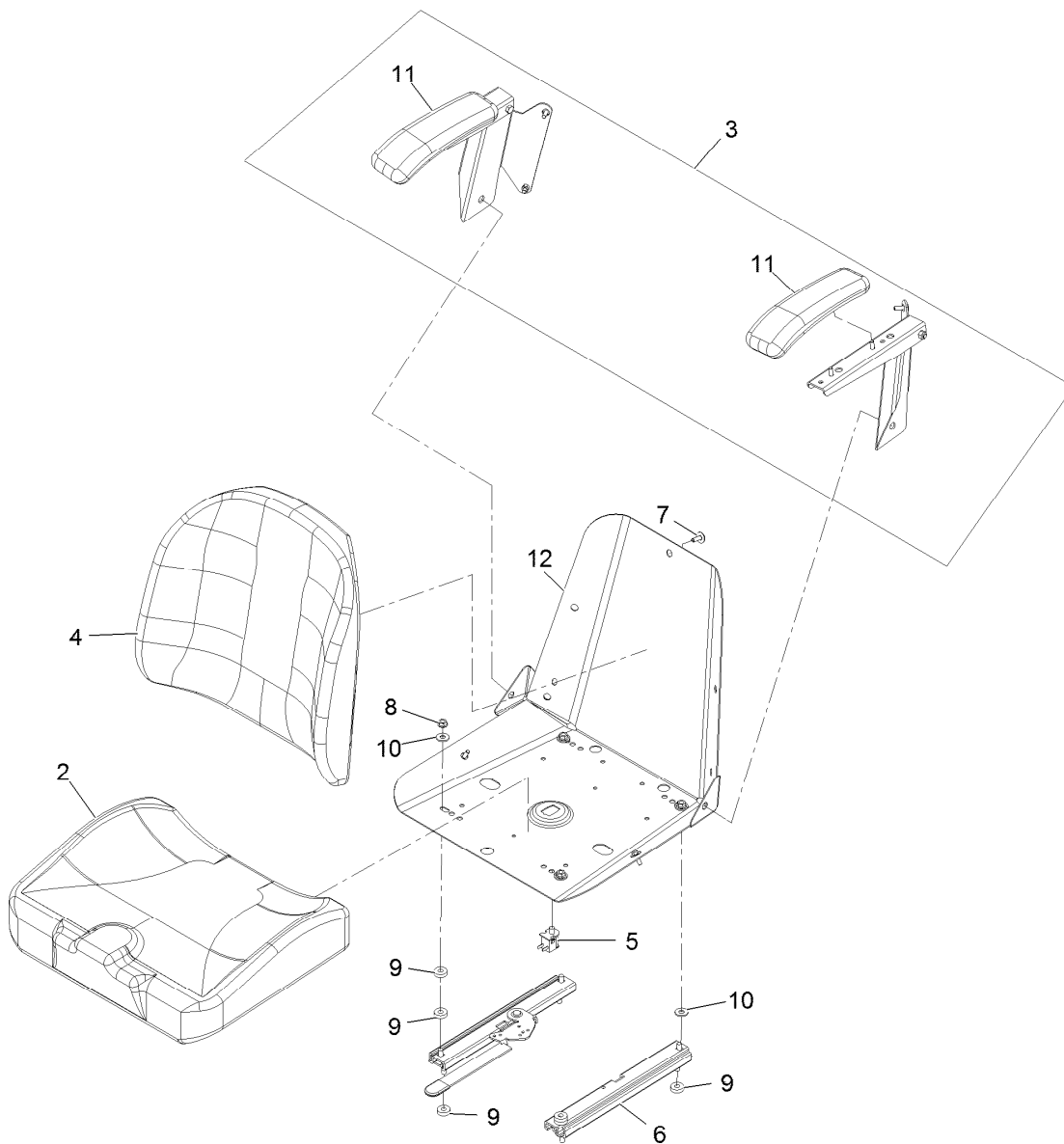

## Seat W/Track Assembly No. 121-5670

<i>Ref.</i>	<i>Part Number</i>	<i>Qty.</i>	<i>Description</i>
2	116-7329	1	Cushion-Seat Bottom
3	110-5719	1	Armrest Kit
4	116-3738	1	Cushion,Seat Back
5	82-2190	1	Switch
6	1-643255	1	Track-Seat
7	103-8383	7	Screw-HWH 1/4-20 X 3/4 Taptite
8	32128-20	4	Nut-Whizlock 5/16-18
9	26-4840	8	Spacer-Pin, Mounting
10	3256-3	6	Washer-5/16 Std
11	110-4163	2	Cushion-Rest, Arm
12	116-7496	1	Frame-Seat

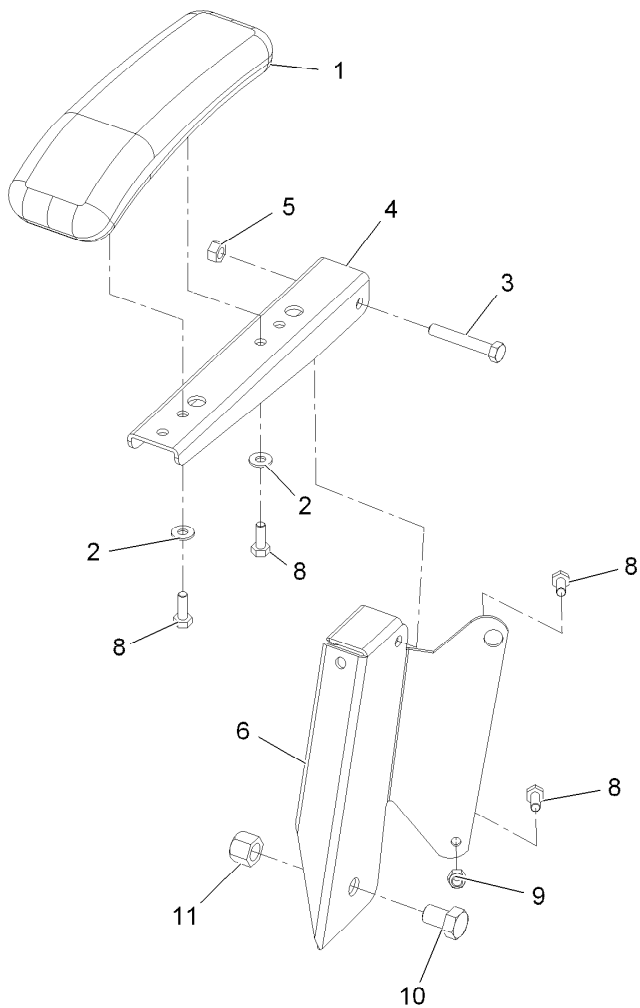

RH Armrest Assembly

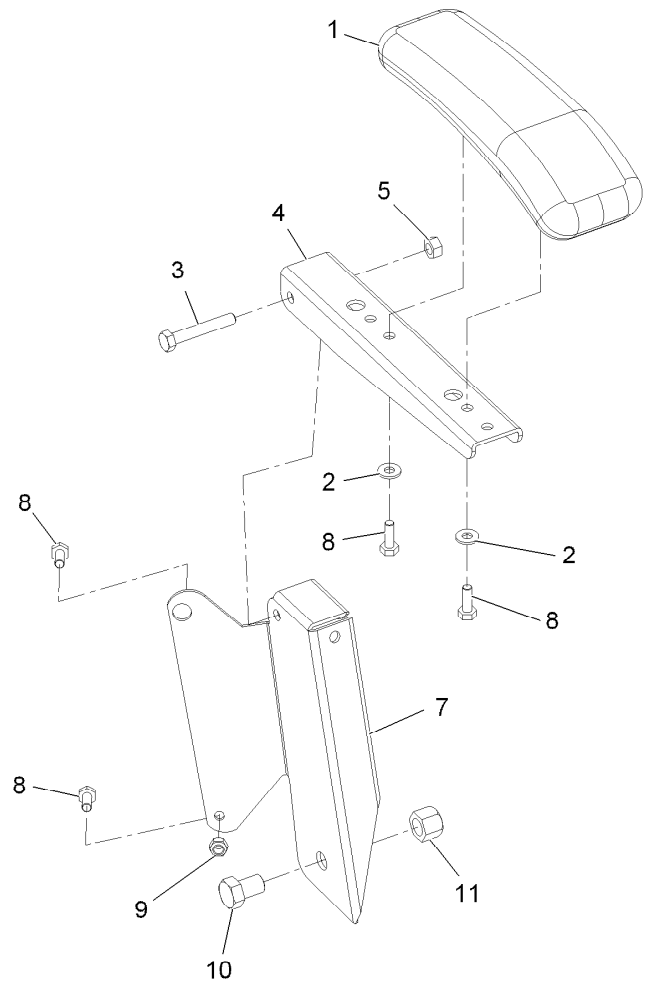

LH Armrest Assembly

## Armrest Kit Assembly No. 110-5719

Ref.	Part Number	Qty.	Description
1	110-4163	2	Cushion-Rest, Arm
2	3256-22	4	Washer-1/4 Sae
3	322-10	2	Screw-HH 5/16-18 X 2
4	105-3623	2	Channel-Armrest
5	32153-3	2	Nut-Hex, Side Deform
6	105-3621	1	Bracket-Armrest, RH
7	105-3622	1	Bracket-Armrest, LH
8	321-30	8	Screw-HH
9	3296-42	4	Nut-Nyloc 1/4-20
10	325-2	2	Screw-HH
11	3296-23	2	Nut-Nyloc 1/2-13

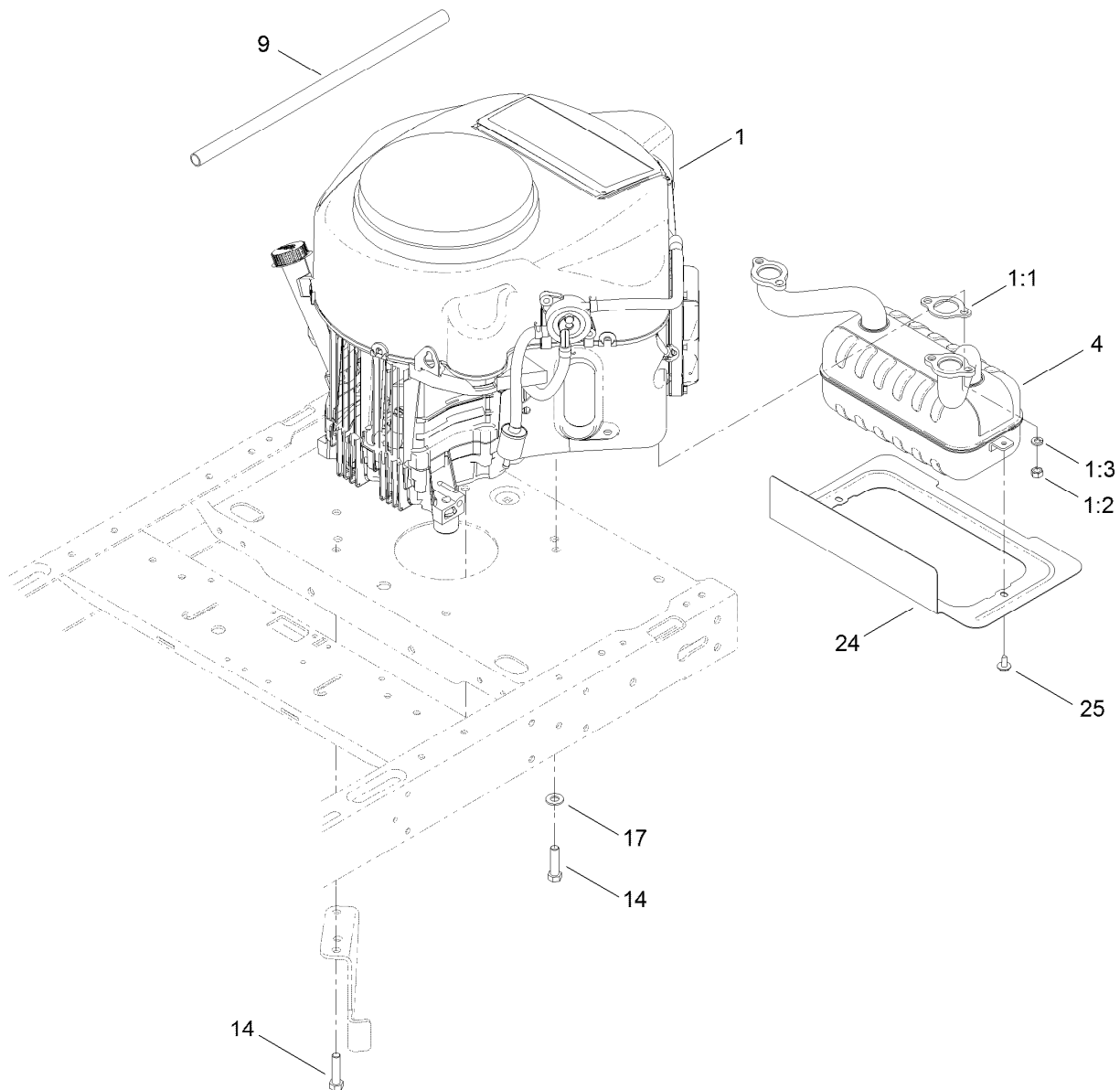

## Engine and Muffler Assembly

Ref.	Part Number	Qty.	Description
1		1	Engine-Kawasaki, Fr691V-_s07-R ●■
1:1	1-653313	2	Gasket-Exhaust
1:2	114-3549	4	Nut
1:3	114-3550	4	Washer-Lock, Spring
4	117-7256	1	Muffler-Kawasaki
9	106-7022	1	Tube-Drain, Oil
14	323-50	4	Bolt-HH
17	3256-24	3	Washer-Flat
24	121-2973-03	1	Shield-Heat
25	46-8560	2	Screw-HHFTF

● Not serviced separately

■ Obtain parts from [www.kawpowerepc.com](http://www.kawpowerepc.com)

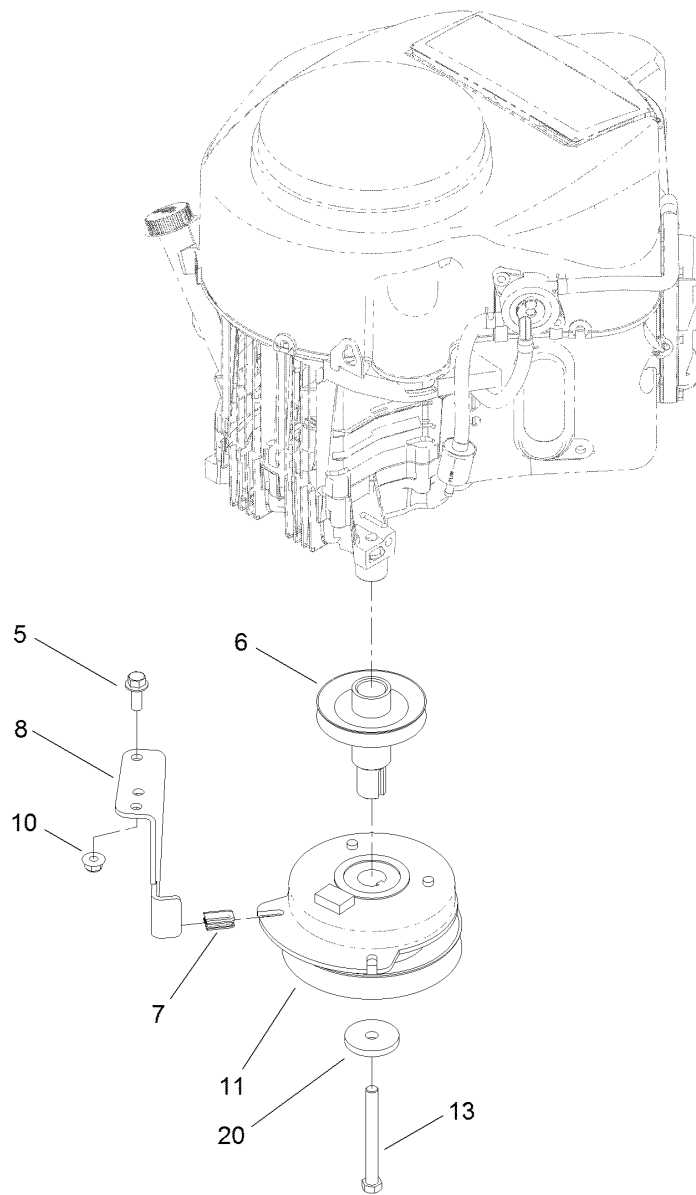

## Clutch Assembly

<i>Ref.</i>	<i>Part Number</i>	<i>Qty.</i>	<i>Description</i>
5	3234-42	1	Screw-HHF
6	119-3318	1	Pulley-Engine
7	120-2217	1	Isolator-Clutch
8	119-8885	1	Stop-Clutch
10	104-8301	1	Nut-Flange, NI
11	119-8941	1	Clutch-PTO
13	3212-19	1	Screw-HH
20	109-6919	1	Washer-Clutch

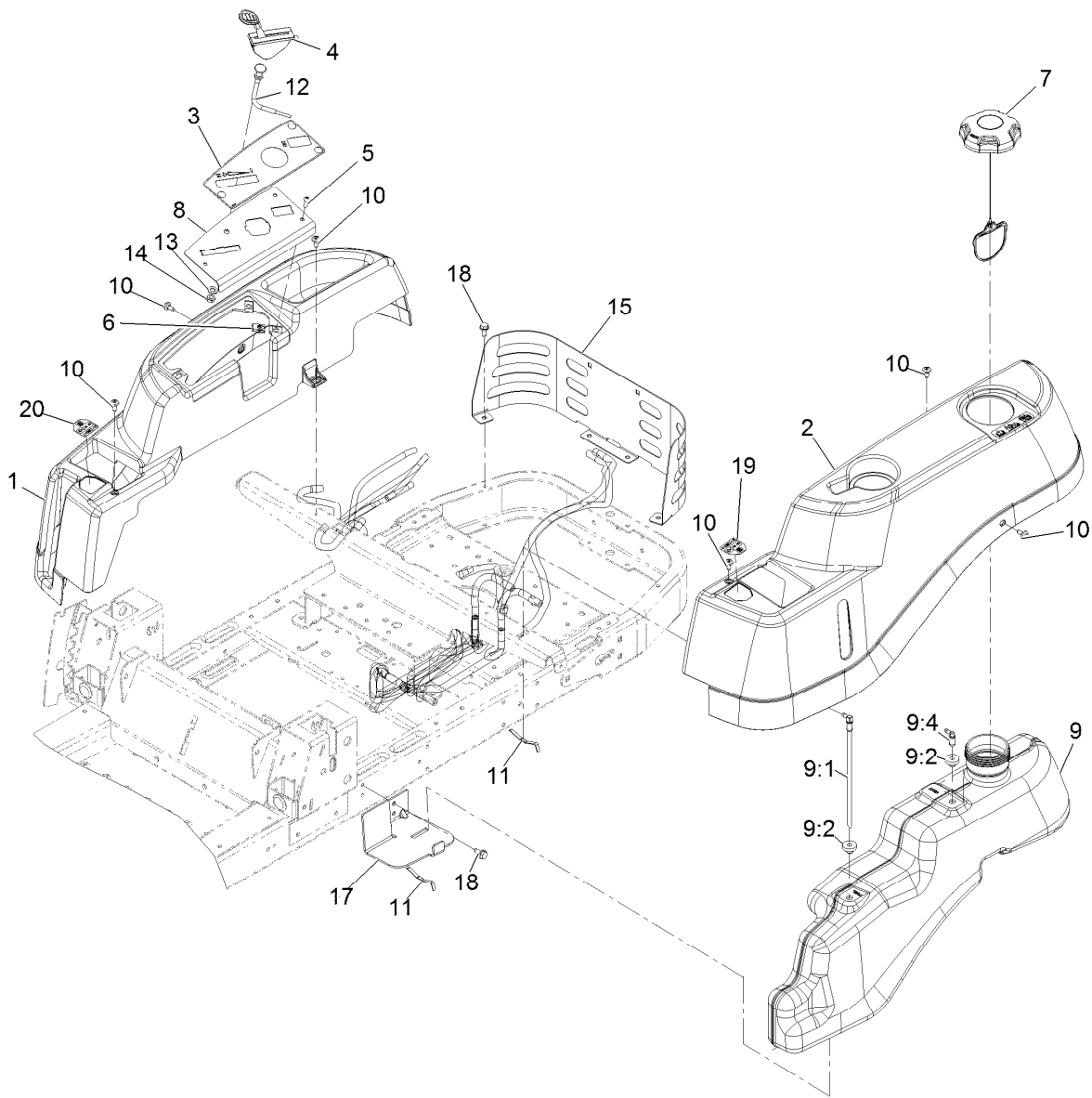

## Controls and Fuel Tank

Ref.	Part Number	Qty.	Description
1	119-8963	1	Pod-RH
2	119-8962	1	Pod-LH
3	116-4220	1	Decal-Panel, Control
4	120-2214	1	Cable-Throttle
5	3258-166	3	Screw-PPH 1/4-20 X 3/4
6	107069	3	Nut-Retainer-Panel 1/4-20
7	120-5461	1	Cap-Fuel, Ratcheting
8	119-3377-03	1	Plate-Control
9	119-3324	1	Fuel Tank ASM
9:1	121-0793	1	Connector-Elbow, 90 DEG
9:2	46-6560	2	Bushing
9:4	117-7400	1	Fitting-Plastic

Ref.	Part Number	Qty.	Description
10	120-7950	6	Screw-Shoulder
11	609830	2	Spring
12	112-9753	1	Cable-Choke
13	3253-21	1	Washer-Lock 3/8
14	3220-3	1	Nut-Jam 3/8-24
15	119-8967-03	1	Guard-Rear
17	119-3395-03	1	Support-Tank, Front
18	32144-70	6	Screw-HWH 5/16-18 X 3/4 Tf
19	119-8814	1	Decal-Control Lever, LH
20	119-8815	1	Decal-Control Lever, RH



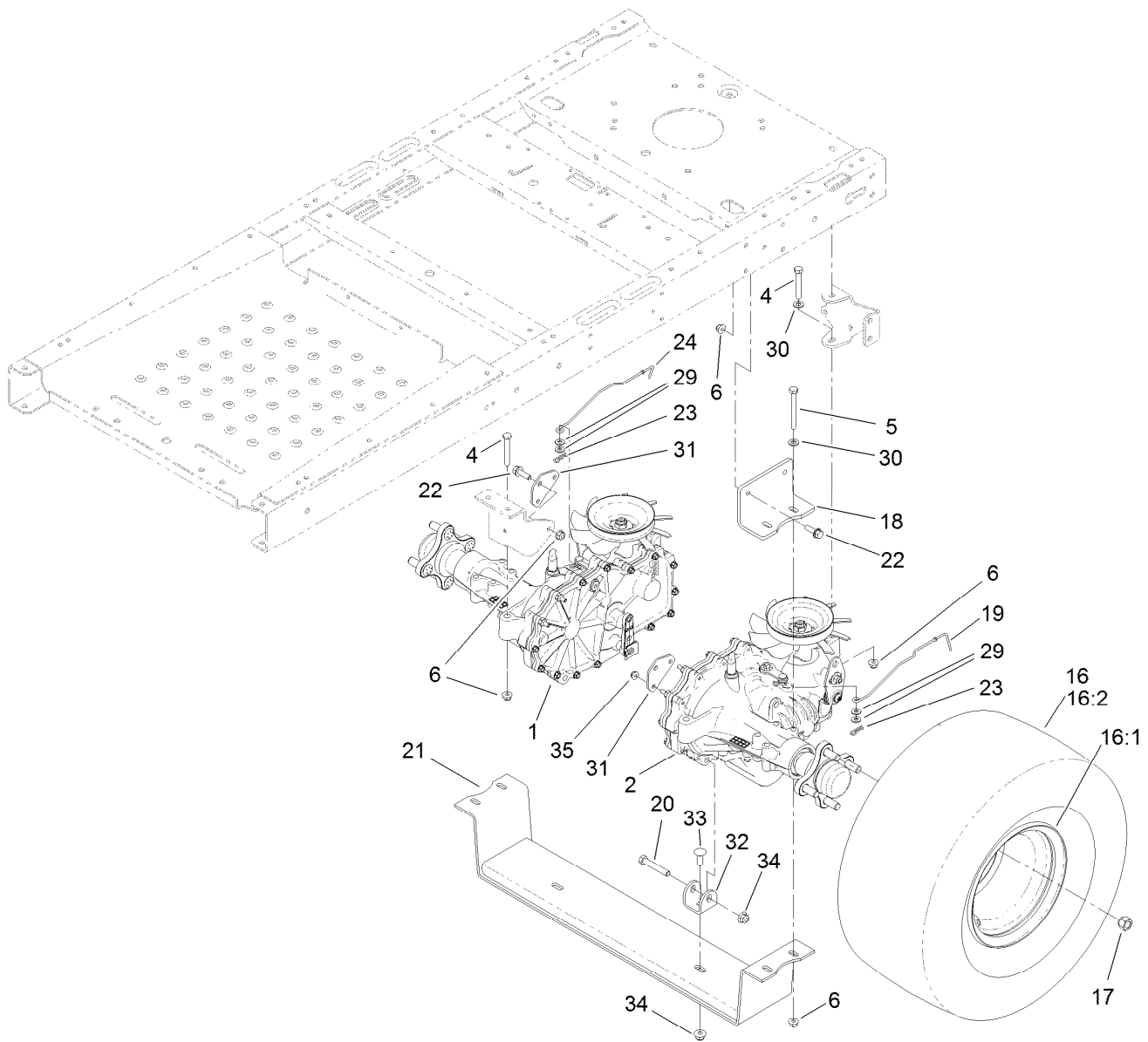

## Hydro Transaxle Drive and Rear Wheel Assembly

Ref.	Part Number	Qty.	Description	Ref.	Part Number	Qty.	Description
1	119-3361	1	RH Hydro Transaxle ASM	21	121-0748-01	1	Mount-Hydro
2	119-3360	1	LH Hydro Transaxle ASM	22	3234-29	6	Screw-HH Flg 5/16-18 X 1
4	322-11	4	Screw-HH 5/16-18 X 2 1/4	23	3290-307	2	Pin-Hair
5	322-14	4	Screw-HH 5/16-18 X 3	24	120-7968	1	Rod-Bypass, RH
6	104-8300	14	Nut-Nyloc 5/16-18 Flg	29	3256-22	4	Washer-1/4 Sae
16	116-3163	2	Wheel And Tire ASM	30	3256-23	6	Washer-5/16 Sae
16:1	116-2299	1	Wheel, 10 X 6.00	31	120-7918	2	Plate-Hydro Mount
16:2	116-3165	1	Tire	32	121-0749	2	Tab-Hydro
17	242-50	8	Nut-Lug 1/2-20	33	3231-2	2	Bolt-Carriage 3/8-16 X 1
18	121-0745-01	2	Mount-Hydro	34	104-8301	4	Nut-Nyloc 3/8-16 Flg
19	121-2965	1	Rod-Bypass, LH	35	104-7201	4	Nut-Nyloc 1/4-20 Flg
20	323-11	2	Screw-HH 3/8-16 X 2 1/4				

# Left Hand Hydro Transaxle Assembly No. 119-3360

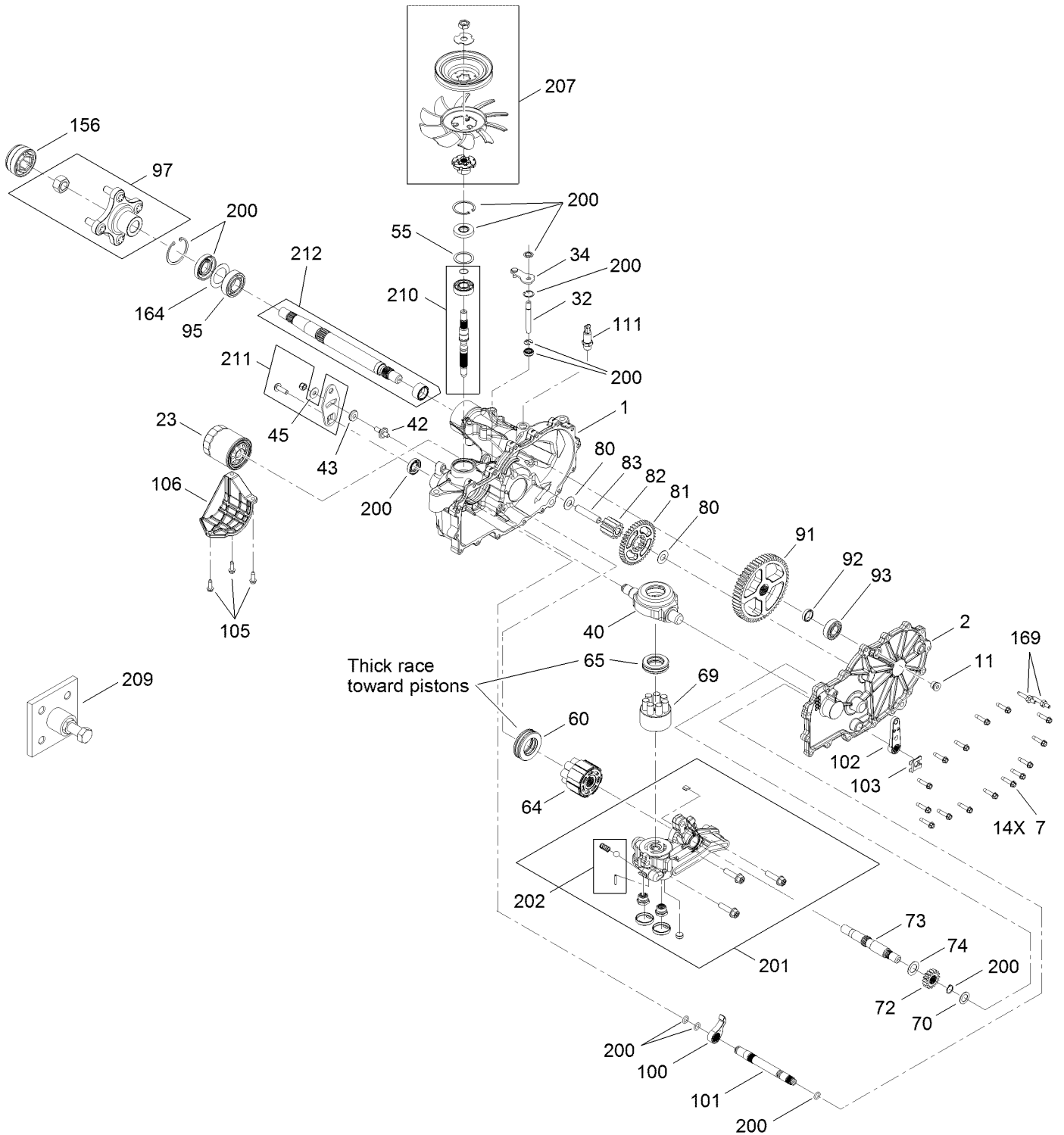

# Left Hand Hydro Transaxle Assembly No. 119-3360 (continued)

<i>Ref.</i>	<i>Part Number</i>	<i>Qty.</i>	<i>Description</i>	<i>Ref.</i>	<i>Part Number</i>	<i>Qty.</i>	<i>Description</i>
1	125-0037	1	Main Housing Kit	91	114-1694	1	Gear-54T
2	117-5358	1	Housing Side Kit	92	120-7975	1	Spacer
7	117-5359	14	Screw-HHF	93	114-1696	1	Bearing-Ball
11	104-2189	1	Plug-Thread, Straight	95	120-7976	1	Bearing-Ball
23	109-3321	1	Element-Oil Filter, HYD	97	109-5939	1	Hub Kit
32	114-1685	1	Rod-Bypass	100	114-1697	1	Pawl-Brake
34	112-9852	1	Arm-Bypass	101	114-1698	1	Shaft-Inboard Brake
40	104-5304	1	Swashplate-Trunnion	102	114-1699	1	Handle-Brake
42	104-2116	1	Stud	103	114-8450	1	Clip-Retaining
43	112-9853	1	Puck-Friction	105	104-2120	3	Screw
45	114-8491	1	Washer	106	120-7981	1	Guard-Filter, RH
55	104-5308	1	Spacer	111	109-3278	1	Adapter-Straight
60	112-4154	1	Bearing-Thrust	156	115-5057	1	Cover-Nut, Axle
64	114-1689	1	Motor Cylinder Block Kit	164	121-5745	1	Spacer
65	94-6922	1	Bearing-Thrust	169	125-0035	2	Stud
69	110-8561	1	Pump Block ASM	200	109-3537	1	Complete Seal Kit
70	104-5339	1	Washer-Flat	201	114-8463	1	RH Center Section Kit
72	121-5749	1	Gear-16T, Steel	202	114-8464	1	Charge Relief Kit
73	114-1691	1	Shaft-Motor	207	121-5746	1	Fan Pulley Kit
74	104-5360	1	Washer	209	114-8467	1	Hub-Puller, 4 Bolt
80	94-1933	2	Washer	210	114-8468	1	Input Shaft Kit
81	125-0000	1	Gear-43T	211	117-5362	1	Arm Control Kit
82	114-1693	1	Gear-11T	212	114-8470	1	Axle Shaft Kit
83	104-5329	1	Pin-Jackshaft				

# Right Hand Hydro Transaxle Assembly No. 119-3361

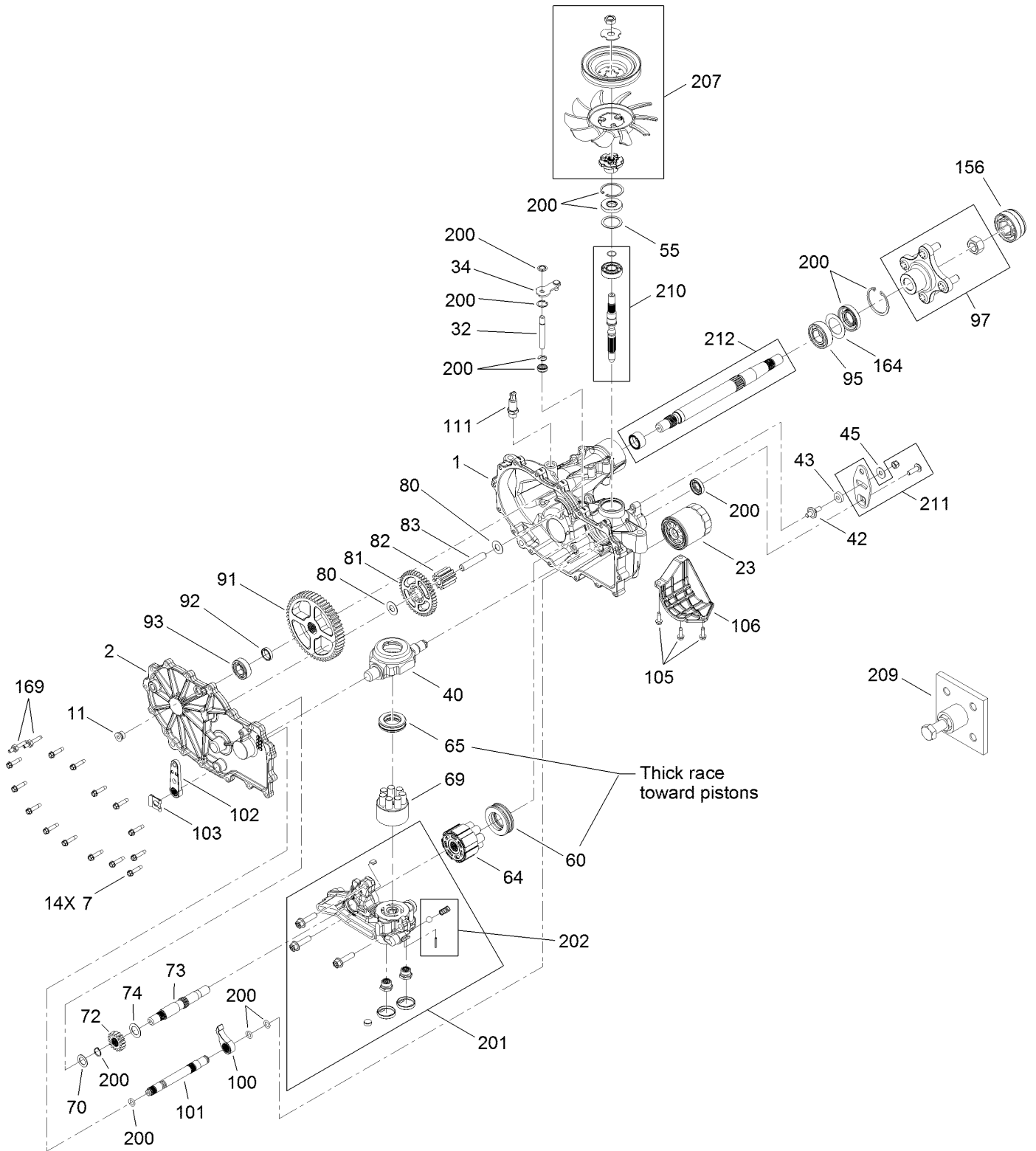

# Right Hand Hydro Transaxle Assembly No. 119-3361 (continued)

<i>Ref.</i>	<i>Part Number</i>	<i>Qty.</i>	<i>Description</i>	<i>Ref.</i>	<i>Part Number</i>	<i>Qty.</i>	<i>Description</i>
1	121-5748	1	Main Housing Kit	91	114-1694	1	Gear-54T
2	114-8472	1	Side Cover Kit	92	120-7975	1	Spacer
7	117-5359	14	Screw-HHF	93	114-1696	1	Bearing-Ball
11	104-2189	1	Plug-Thread, Straight	95	120-7976	1	Bearing-Ball
23	109-3321	1	Element-Oil Filter, HYD	97	109-5939	1	Hub Kit
32	114-1685	1	Rod-Bypass	100	114-1697	1	Pawl-Brake
34	107-2490	1	Arm-Bypass	101	114-1698	1	Shaft-Inboard Brake
40	104-5304	1	Swashplate-Trunnion	102	114-1699	1	Handle-Brake
42	104-2116	1	Stud	103	114-8450	1	Clip-Retaining
43	112-9853	1	Puck-Friction	105	104-2120	3	Screw
45	114-8491	1	Washer	106	120-7979	1	Guard-Filter, LH
55	104-5308	1	Spacer	111	109-3278	1	Adapter-Straight
60	112-4154	1	Bearing-Thrust	156	115-5057	1	Cover-Nut, Axle
64	114-1689	1	Motor Cylinder Block Kit	164	121-5745	1	Spacer
65	94-6922	1	Bearing-Thrust	169	125-0035	2	Stud
69	110-8561	1	Pump Block ASM	200	109-3537	1	Complete Seal Kit
70	104-5339	1	Washer-Flat	201	125-0036	1	Center Section Kit
72	121-5749	1	Gear-16T, Steel	202	114-8464	1	Charge Relief Kit
73	114-1691	1	Shaft-Motor	207	121-5746	1	Fan Pulley Kit
74	104-5360	1	Washer	209	114-8467	1	Hub-Puller, 4 Bolt
80	94-1933	2	Washer	210	114-8468	1	Input Shaft Kit
81	125-0000	1	Gear-43T	211	117-5362	1	Arm Control Kit
82	114-1693	1	Gear-11T	212	114-8470	1	Axle Shaft Kit
83	104-5329	1	Pin-Jackshaft				

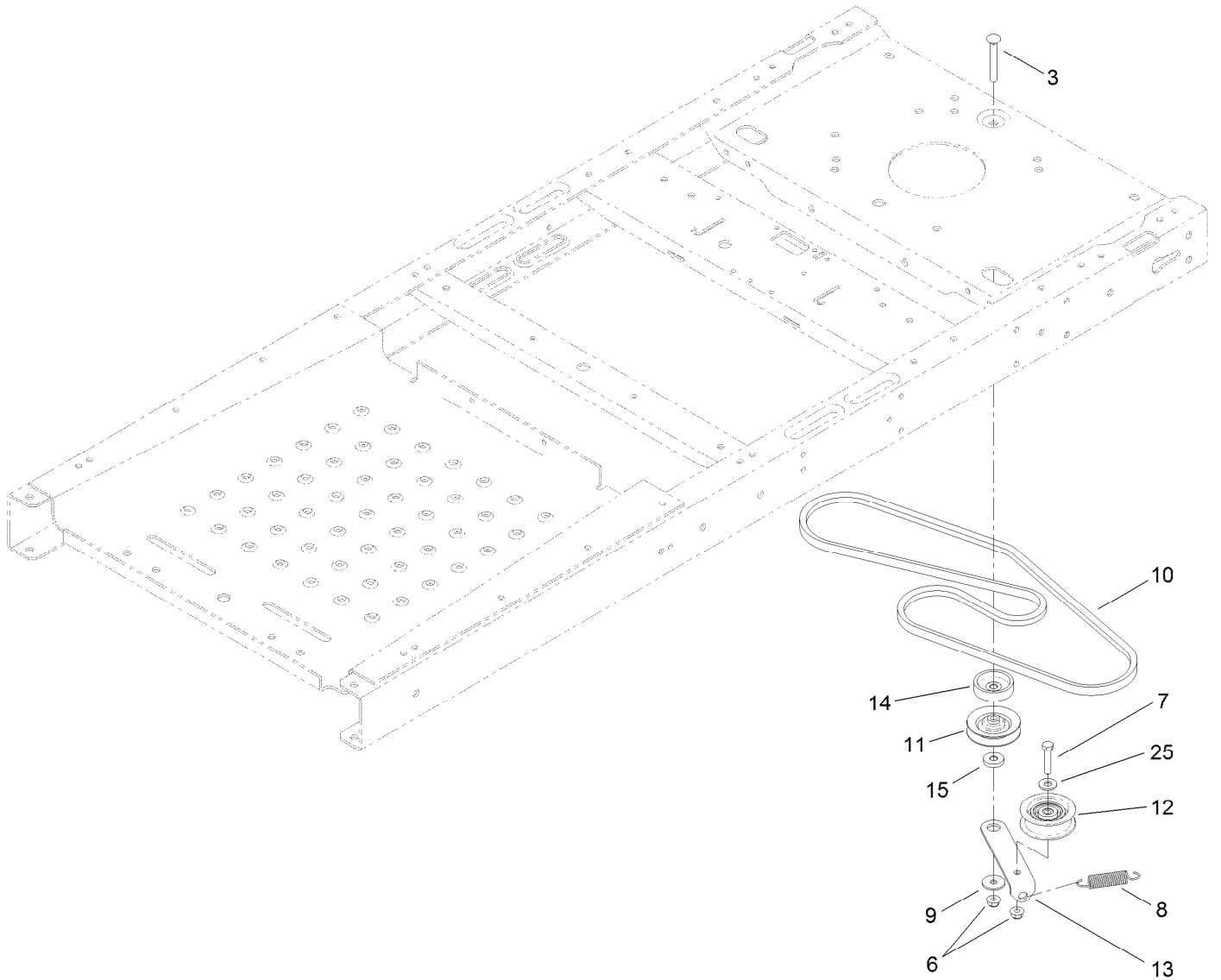

## Belt and Pulley Assembly

Ref.	Part Number	Qty.	Description
3	3230-8	1	Screw-CARR
6	104-8300	2	Nut-Flange, NI
7	322-7	1	Screw-HH
8	104-6415	1	Spring-Return, Pedal
9	5-4460	1	Washer-Pivot
10	119-3321	1	V-Belt
11	119-8822	1	Pulley-Idler
12	106-2176	1	Pulley-Idler
13	119-3326	1	Arm-Idler
14	119-3353	1	Spacer
15	119-3327	1	Spacer-Arm, Idler
25	3256-3	1	Washer-Flat

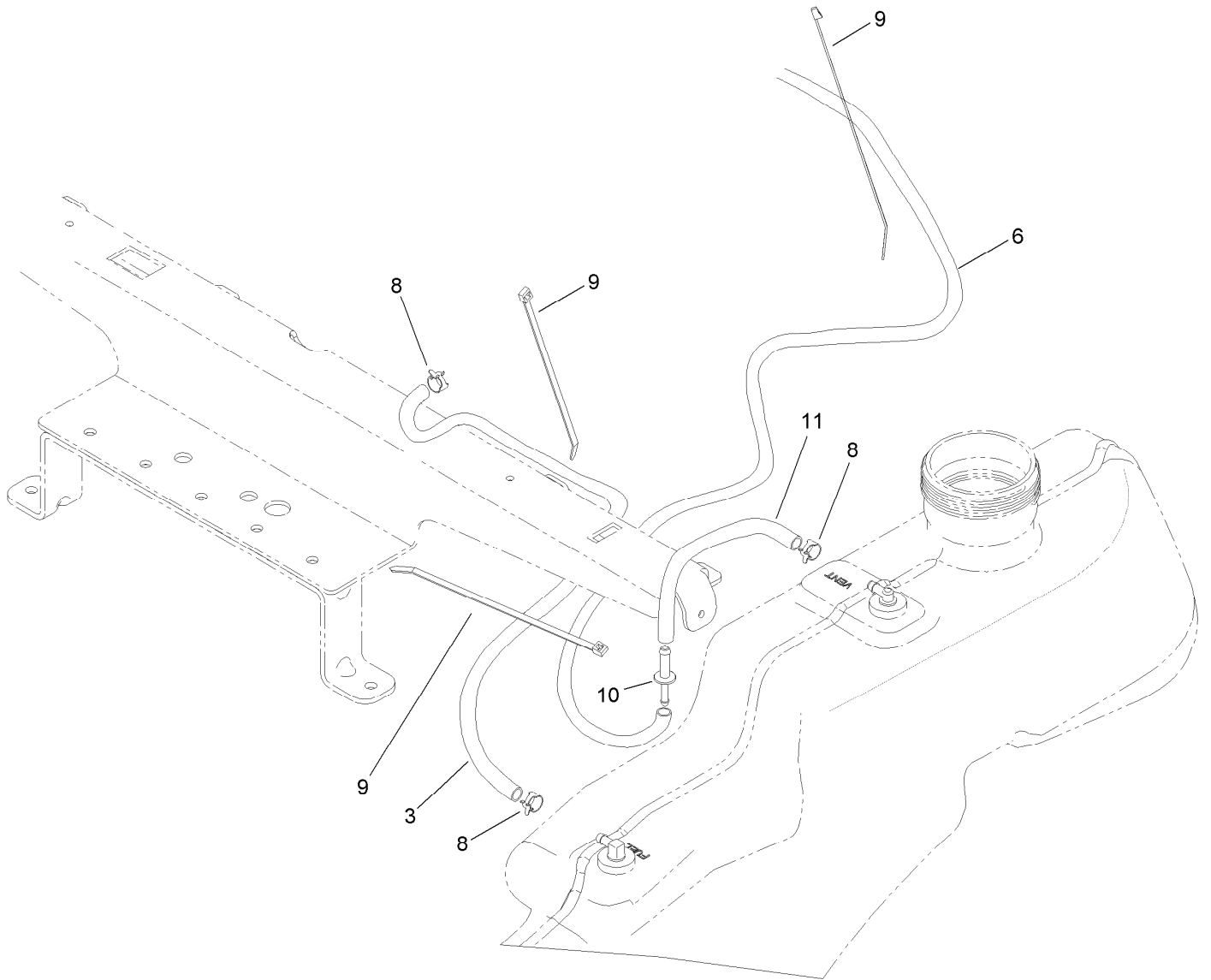

## Fuel Delivery Assembly

Ref.	Part Number	Qty.	Description
3	109-0301	1	Hose-Fuel
6	51-3212	1	Hose-Fuel
8	2412-98	3	Clamp-Hose
9	614249	3	Tie-Cable
10	117-5399	1	Adaptor-Orifice
11	110-1876	1	Hose-Fuel

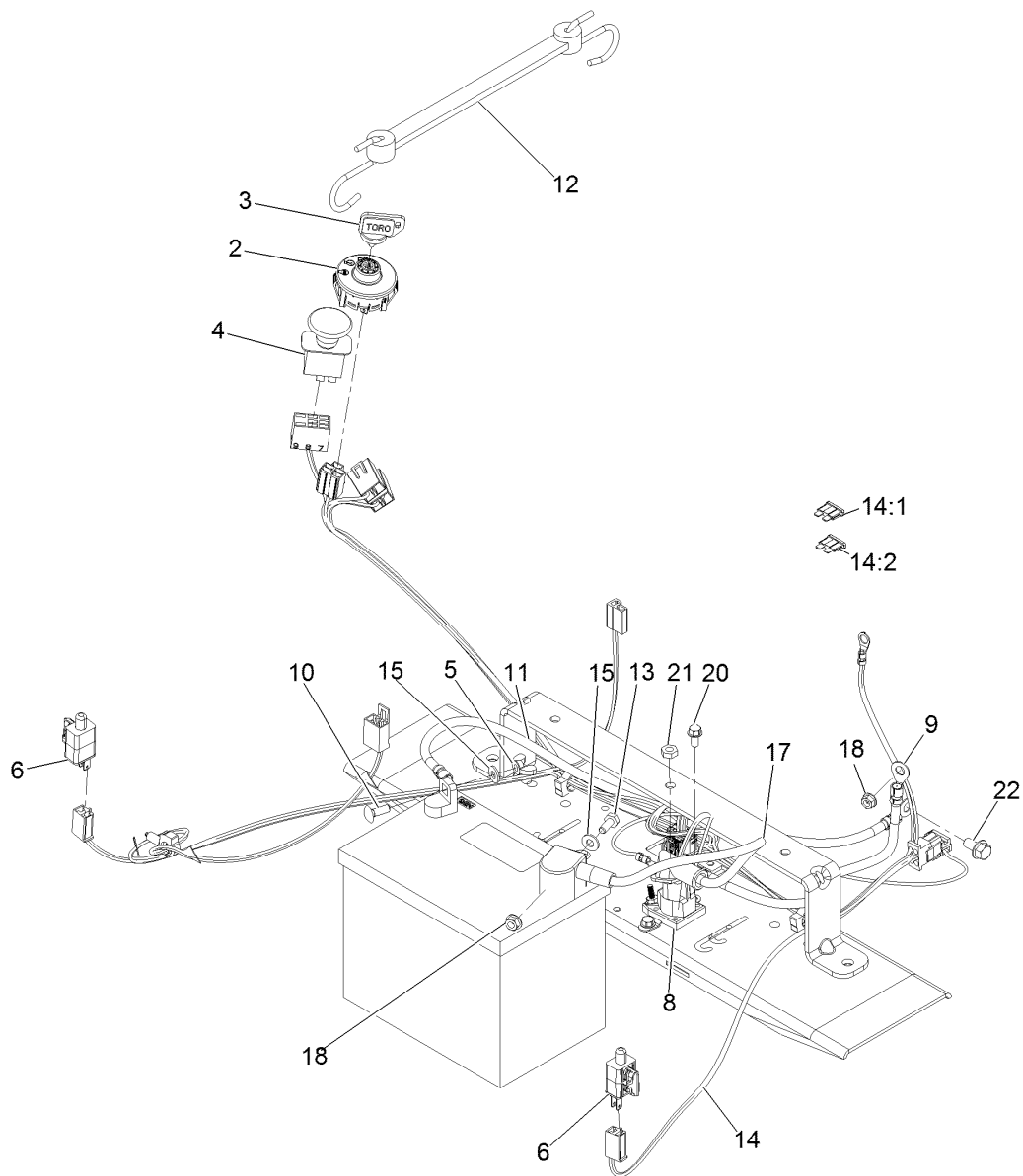

## Electrical Assembly

Ref.	Part Number	Qty.	Description	Ref.	Part Number	Qty.	Description
2	117-2221	1	Switch-Ignition	14	121-5652	1	Harness-Wire
3	103-2106	1	Key-Exmark Logo	14:1	109103	1	Fuse-Blade, 30 Amp
4	103-5221	1	Switch-PTO	14:2	109102	1	Fuse-Blade, 25 Amp
5	32103-22	1	Nut-Wing	15	3256-22	2	Washer-1/4 Sae
6	110-6765	2	Switch-Single Pole No	17	119-8897	1	Cable-Battery, Red
8	117-1197	1	Solenoid	18	32128-33	2	Nut-Whizlock 1/4-20
9	119-8898	1	Cable-Battery, Red	20	32144-4	2	Screw-HWH 1/4-20 X 1/2 Taptite
10	3229-1	1	Bolt-Carriage 1/4-20 X 3/4	21	3220-2	2	Nut-Jam 5/16-24
11	119-8899	1	Cable-Battery, Black	22	33104-016	1	Screw-HHF
12	104-2466	1	Holddown-Battery				
13	321-3	1	Screw-HH 1/4-20 X 5/8				



**Notes:**

**Notes:**

# EXMARK® MAINTENANCE

## MAXIMIZE THE PERFORMANCE OF YOUR EXMARK.

### **4-CYCLE PREMIUM ENGINE OIL**

Part No. 116-3373

Both SAE 30 and SAE 10W-30 in one bottle.

Contains increased levels of zinc and phosphorus for better lubricity.

No Viscosity Index Improvers that tend to shear down in high heat.

Synthetic formulation.

Gas & Diesel compatible.

Anti-corrosion additives.

API 'SL' and JASO rated with wet clutch compatibility for other machines.

### **PREMIUM HYDRO OIL**

Part No. 109-9828

Commercial quality for tough, high-heat conditions.

Designed specifically for zero-turn mower hydraulic systems.

Superior shear resistance under heavy loads.

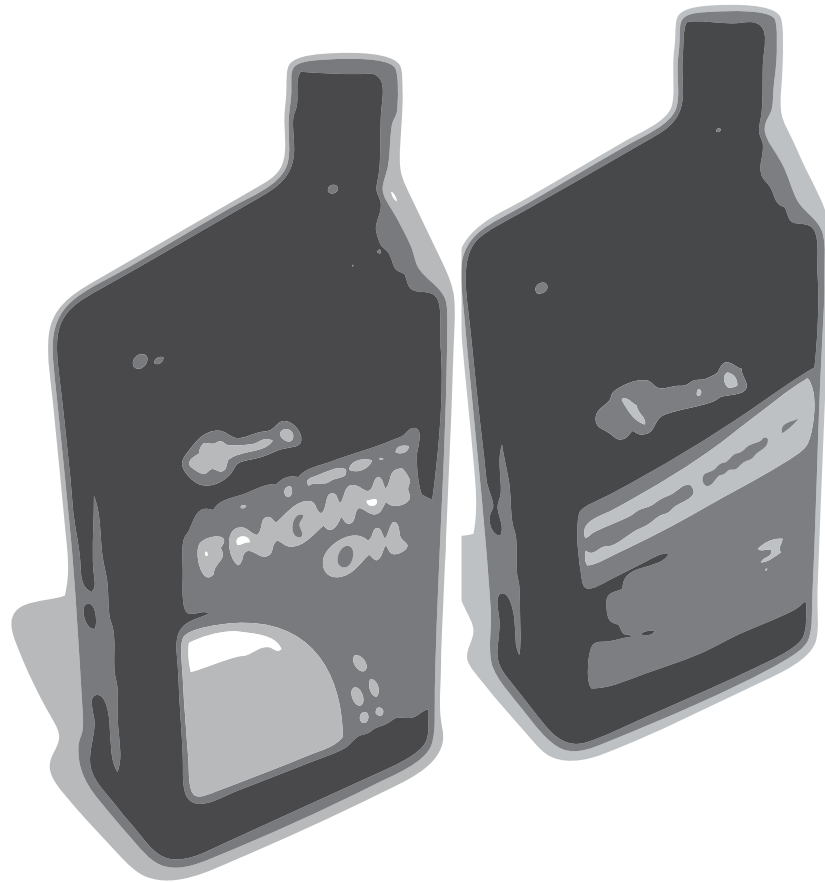

Available from your local Exmark dealer. Find your closest dealer at [exmark.com](http://exmark.com)

## EXMARK ACCESSORIES AND OPTIONS\*

### MID-MOUNT RIDING ACCESSORIES AND OPTIONS

CUSTOM RIDE SEAT SUSPENSION SYSTEM	OPERATOR CONTROLLED DISCHARGE
FULL SUSPENSION SEAT	SUN SHADE
DECK LIFT ASSIST KIT	TRASH CONTAINER
HITCH KIT	TURF STRIPER
LIGHT KIT	ULTRA VAC COLLECTION SYSTEM
12V POWER PORT	ULTRA VAC QUICK DISPOSAL SYSTEM
MICRO-MULCH SYSTEM	

### OUT-FRONT RIDING ACCESSORIES AND OPTIONS

CUSTOM RIDE SEAT SUSPENSION SYSTEM	SNOW BLADE
DUAL-TAIL WHEEL	SNOWBLOWER
FLOOR PAN EXTENDER	SUN SHADE
HITCH KIT	TRASH CONTAINER
LIGHT KIT	ULTRA VAC COLLECTION SYSTEM
MICRO-MULCH SYSTEM	ULTRA VAC QUICK DISPOSAL SYSTEM
ROLL OVER PROTECTION SYSTEM (ROPS)	WEATHER CAB

### WALK-BEHIND ACCESSORIES AND OPTIONS

GRASS CATCHER	TURF STRIPER
MICRO-MULCH SYSTEM	STANDON

\*Some accessories and options not available for some models.

Place Model No. and Serial No.  
Label Here (Included in the Literature  
Pack) or Fill in Below

Model No. \_\_\_\_\_

Serial No. \_\_\_\_\_

Date Purchased \_\_\_\_\_

Engine Model No. and Spec. No. \_\_\_\_\_

Engine Serial No. (E/No) \_\_\_\_\_

© 2013 Exmark Mfg. Co., Inc.  
Industrial Park Box 808  
Beatrice, NE 68310  
All Rights Reserved

Part No. 4501-557 Rev. B  
(402) 223-6290  
Fax (402) 223-5489  
Printed in the USA.

