

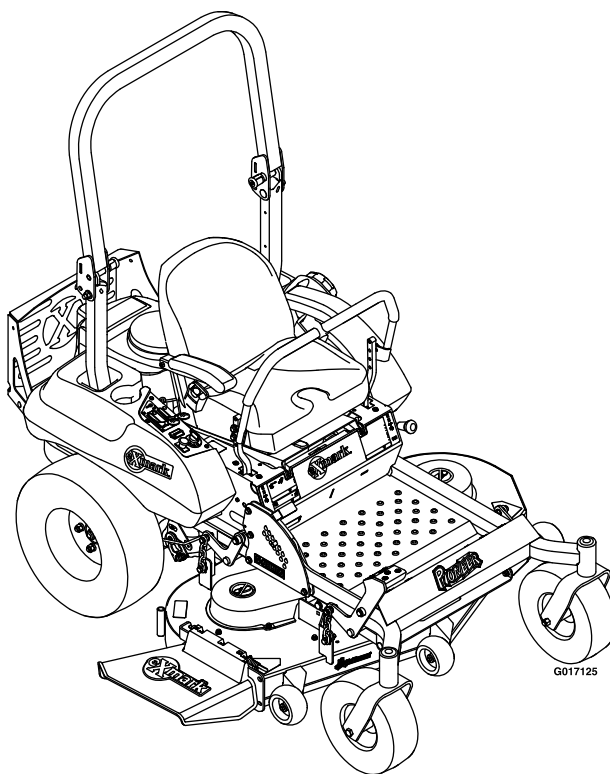

# PIONEER® E-SERIES

Model No. PNE691KA522—Serial No. 31400000 and Up

Picture below may not reflect actual product.



# Parts Manual

Part No. 4501-716 Rev. A

# Ordering Replacement Parts

To order replacement parts, please supply the part number, the quantity, and the description of each part desired.

## Understanding Reference Numbers

Each identified part in an illustration has a reference number. The reference number for a part also appears in the parts list, along with other information about the part.

This catalog uses two special reference number formats, one to indicate parts in a service assembly and another to indicate the quantity of a given part in an illustration.

## Service Assembly Reference Numbers

Parts in service assemblies have reference numbers in the form a:b. The a represents the reference number of the entire service assembly and the b represents a sequential number unique to each part within the service assembly.

For example, a wheel assembly might be identified by reference number 6, the tire by 6:1, the valve by 6:2, and the wheel by 6:3. When you order the assembly identified by reference number 6, you receive all parts identified by reference numbers 6:1, 6:2, and 6:3. However, you may also order any part individually. Reference numbers of this type appear in illustration and in parts lists.

## Reference Numbers Indicating Quantity

In an illustration, if a reference number indicates more than one part, the reference number has the form nX y. The n represents the quantity of the part, the X is the multiplication symbol, and the y represents the reference number.

For example, in an illustration, the reference number 2X 37 means that two of the parts identified by reference number 37 are indicated.

# List of Abbreviations

<b>AR:</b> as required	<b>HJ:</b> hex jam	<b>PRH:</b> phillips round head
<b>ASM:</b> assembly	<b>HLH:</b> hex lag head	<b>PTH:</b> phillips truss head
<b>BBC:</b> blade brake control	<b>HOC:</b> height-of-cut	<b>PTO:</b> power-take-off
<b>BHTF:</b> button head thread forming	<b>HSBH:</b> hex socket button head	<b>RH:</b> right hand
<b>CARR:</b> carriage	<b>HSFH:</b> hex socket flat head	<b>ROPS:</b> roll-over protection system
<b>CCW:</b> counter clockwise	<b>HSH:</b> hex socket head	<b>RRB:</b> rear roller brush
<b>CW:</b> clockwise	<b>HWH:</b> hex washer head	<b>SFH:</b> slotted fillister head
<b>DEG:</b> degrees	<b>HWHTF:</b> hex washer head thread forming	<b>SHH:</b> slotted hex head
<b>DPA:</b> Dual Point Adjustment	<b>HYD:</b> hydraulic	<b>SHWH:</b> slotted hex washer head
<b>ECM:</b> electronic control module	<b>LH:</b> left hand	<b>SPH:</b> slotted pan head
<b>EXT:</b> external	<b>LP:</b> Liquefied Petroleum Gas	<b>SQH:</b> square head
<b>FH:</b> flat head	<b>LPG:</b> Liquefied Petroleum Gas	<b>SRH:</b> slotted round head
<b>GA:</b> gauge	<b>NI:</b> nylon insert	<b>STD:</b> standard
<b>HD:</b> heavy-duty	<b>NPTF:</b> national pipe thread fine	<b>TAP:</b> self tapping
<b>HF:</b> hex flange	<b>PFH:</b> phillips flat head	<b>TTH:</b> torx truss head
<b>HH:</b> hex head	<b>PPH:</b> phillips pan head	
<b>HHF:</b> hex head flange	<b>PPHTF:</b> phillips pan head thread forming	
<b>HHFTF:</b> hex head flange thread forming		

# Touch Up Paint

Exmark black touch up spray paint – gloss black.

Exmark red touch up paint (spray paint – P/N 1-850337 - .6 oz liquid bottle – P/N 103-9140).



If your Exmark dealer does not have the Exmark part in stock, Exmark will get the parts to the dealer the next business day or the part will be FREE Guaranteed!! (Some restrictions apply. See your participating Exmark Dealer for details.)

## Contents

Complete Deck Assembly No. 116-4809 .....	4
Deck Assembly .....	5
Deck W/Decals Assembly No. 116-5048 .....	6
Main Frame Assembly .....	7
Mainframe W/Decals Assembly No. 116-6831 .....	8
Roll-Over Protection System Assembly No. 116-3498 .....	9
Caster Wheel Assembly No. 120-2251 .....	10
Deck Lift Assembly .....	11
Motion Control Assembly .....	12
Motion Control Assembly - LH .....	13
Motion Control Assembly - RH .....	14
Seat Assembly .....	15
Seat W/Tracks Assembly No. 116-6192 .....	16
Controls Assembly .....	17
Fuel Tank Assembly .....	18
Fuel Tank Assembly No. 116-4610 .....	19
Engine Assembly .....	20
Hydraulic Assembly .....	21
Transaxle Assembly .....	22
Electrical Assembly .....	23

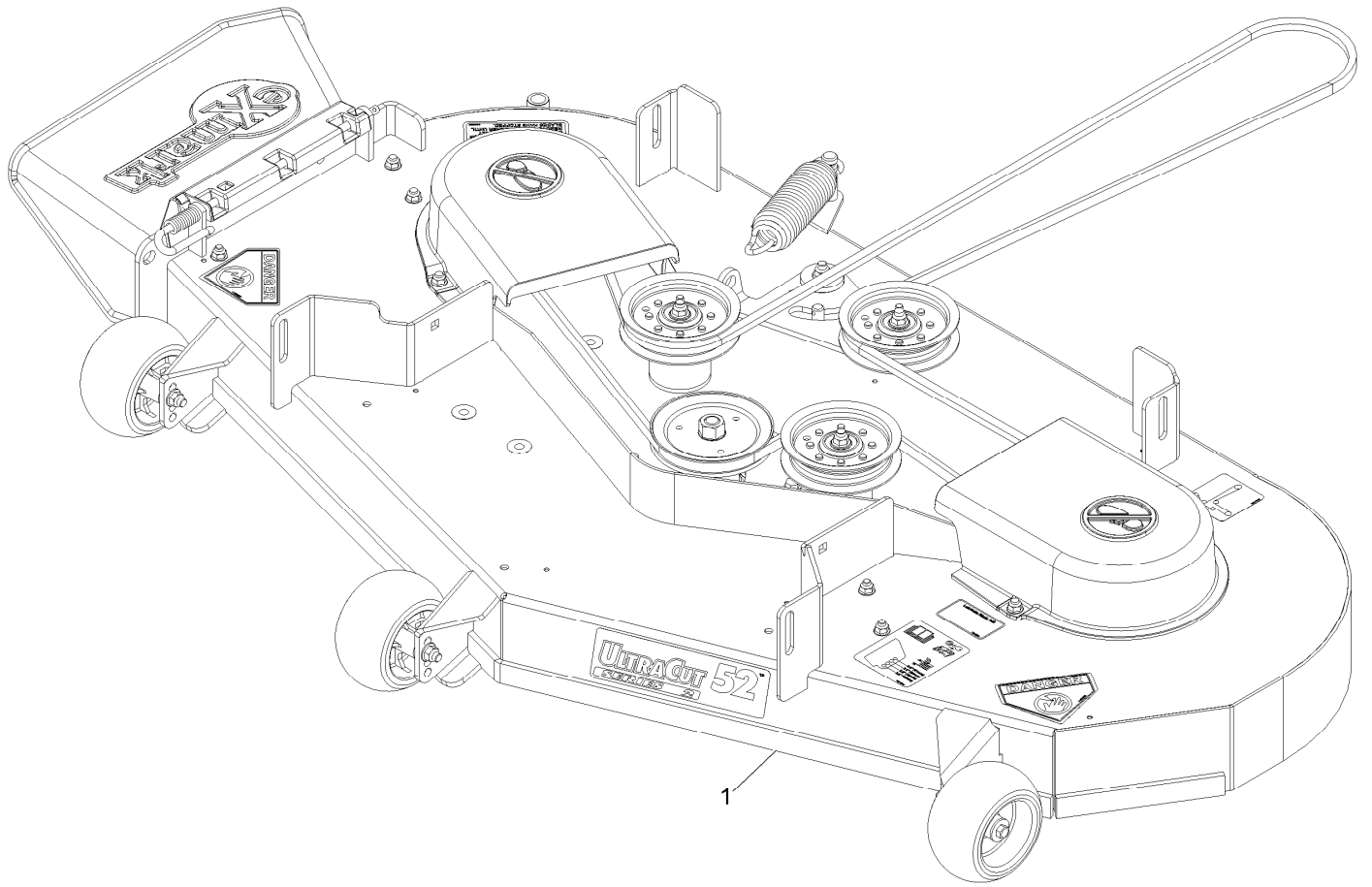

## Complete Deck Assembly No. 116-4809

<i>Ref.</i>	<i>Part Number</i>	<i>Qty.</i>	<i>Description</i>
1	116-4809	1	ASM-Deck Complete 522

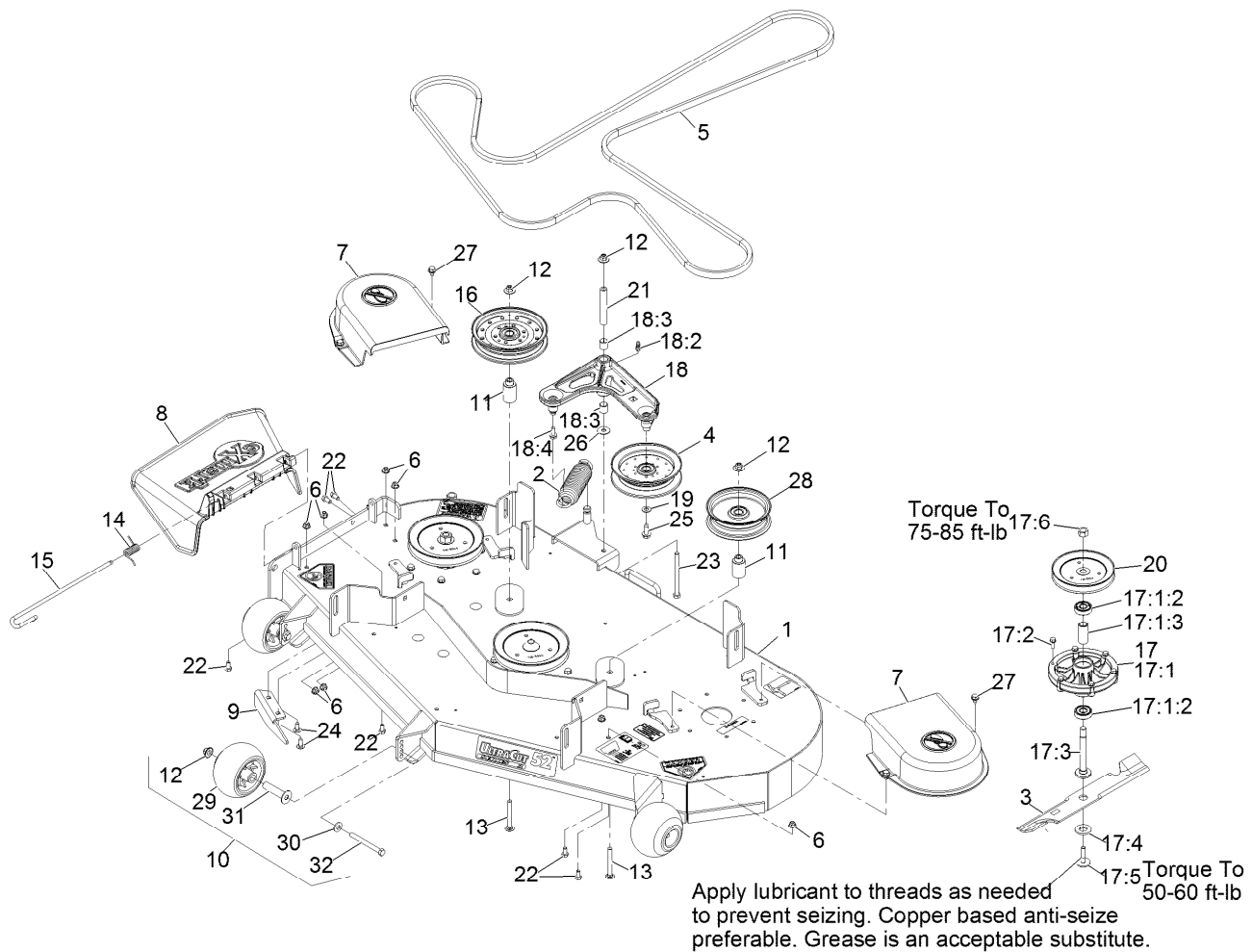

## Deck Assembly

Ref.	Part Number	Qty.	Description	Ref.	Part Number	Qty.	Description
1	116-5048	1	ASM-522 Deck W/Decals	17:3	109-7431	1	Spindle-Hex Pilot
2	116-6317	1	Spring-Extension	17:4	109-7429	1	Washer-Blade Drive
3	103-6402	3	Blade-Notched	17:5	116-0005	1	Bolt-Blade, Sem
3	103-6387	3	Blade, Low Lift	17:6	3219-6	1	Nut-Hex 5/8-18
3	103-6382	3	Blade, Solid	18	126-0976	1	ASM-Idler Arm W/Bearings
3	109-6390	3	Blade. Mulch ●	18:2	302-40	1	Zerk-90° 1/4-28
3	116-5175	3	Blade-Extreme 2, 18.00"	18:3	1-513034	2	Sleeve-Bearing
4	116-4668	1	Idler-Pulley, Flanged	18:4	32144-11	1	Screw-HWH 5/16-18 X 3/4 Tf
5	103-9273	1	Belt, Deck Drive (60")	19	3256-24	1	Washer-3/8 Sae
6	104-8300	8	Nut-Nyloc 5/16-18 Fig	20	116-5044	3	Sheave,Blade Drive 6.50
7	109-3449	2	Shield-Belt	21	116-5111	1	Bushing
8	109-5151	1	Deflector-Discharge	22	322-2	6	Screw-HH 5/16-18 X 5/8
9	109-5498-03	1	Baffle-Discharge	23	323-23	1	Screw-HH 3/8-16 X 4-1/2
10	116-9981	3	Kit, Anti-Scalp Roller	24	3230-23	2	Bolt-Carriage 5/16-18 X 3/4 Short Neck
11	109-6572	2	Bushing-Idler	25	126-1696	1	Screw-Thread Forming
12	109-6658	6	Nut-Nyloc 3/8-16 Flg	26	52-2860	1	Washer
13	109-6868	2	Bolt-Carriage 3/8-16 X 3	27	9266934	4	Screw-HWH 5/16 X 1/2 Tf
14	109-6886	1	Spring-Torsion	28	116-4669	1	Pulley-Idler Flat
15	109-8854	1	Pin-Chute	29	103-8415	3	Roller, Anti-Scalp
16	116-4670	1	Pulley-Idler, Flat	30	98-5975	3	Washer-Spring Disc 3/8
17	116-5138	3	Cutter Housing ASM	31	116-8131	3	Axle, Roller
17:1	116-5137	1	Housing-Cutter	32	116-9362	3	Screw-HH 3/8-16 X 3 3/4 Gr 8
17:1:2	116-4004	2	Bearing				
17:1:3	116-4876	1	Spacer-Bearing				
17:2	32144-41	6	Screw-HWH 3/8-16 X 7/8 Taptite				

● Requires installation of mulch kit for proper mulching. See your Exmark dealer for details.

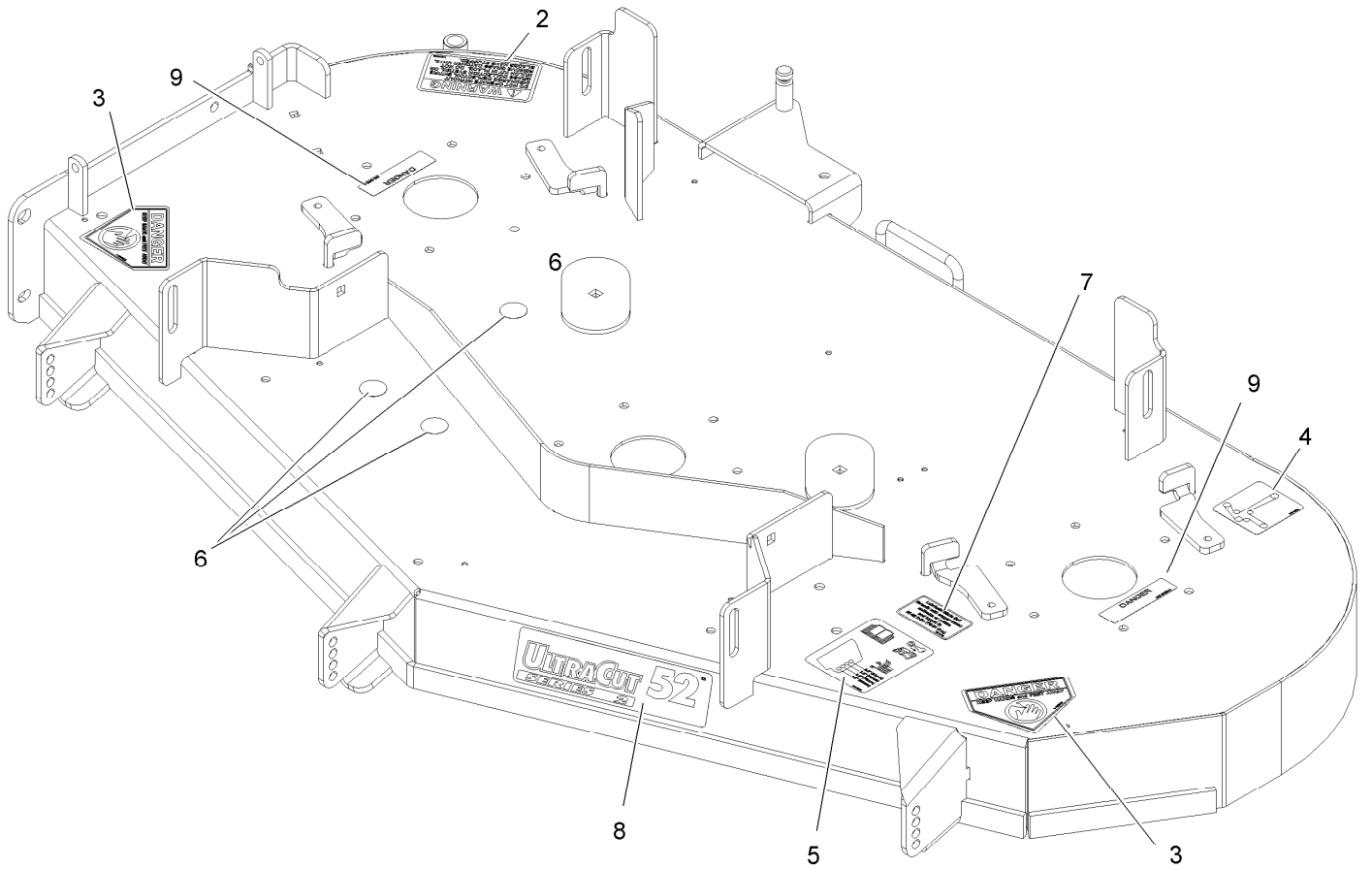

## Deck W/Decals Assembly No. 116-5048

<i>Ref.</i>	<i>Part Number</i>	<i>Qty.</i>	<i>Description</i>
2	1-303508	1	Decal-Warning, Discharge
3	1-403005	2	Decal-Danger
4	109-6035	1	Decal-Belt Routing
5	109-6036	1	Decal-Roller, Anti-Scalp
6	109-9159	3	Decal-Hole Cover
7	109-3148	1	Decal, Bolt Torque
8	116-4698	1	Decal-Ultracut 52 Series 2
9	98-5954	2	Decal-Cover, Missing

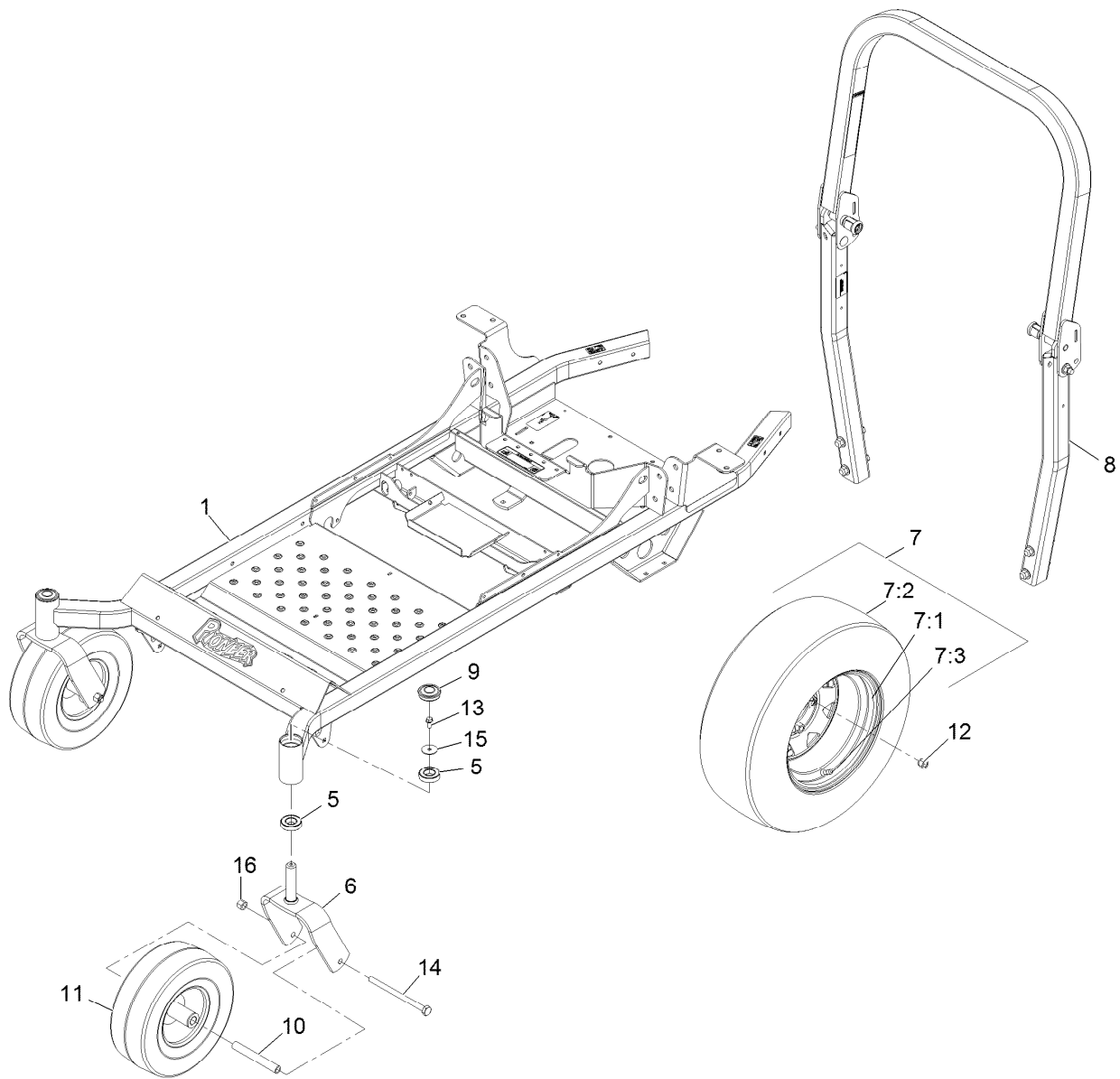

## Main Frame Assembly

Ref.	Part Number	Qty.	Description	Ref.	Part Number	Qty.	Description
1	116-6831	1	Frame ASM-48-52	9	116-4348	2	Cap-Grease
5	109-3678	4	Bearing-Ball	10	119-3475	2	Spanner
6	116-0611-01	2	Wld,Caster Fork	11	120-2251	2	ASM-Tire And Wheel, 13 In Smooth
7	116-7331	2	ASM-Wheel And Tire 20 X 8.00-10	12	242-50	8	Nut-Lug 1/2-20
7:1	116-7332	1	Wheel-10 X 6.00	13	3234-5	2	Screw-HH Flg 5/16-18 X 3/4
7:2	116-7333	1	Tire-20 8.00-10	14	325-36	2	Screw-HH 1/2-13 X 7 1/2
7:3	232-27	1	Stem-Valve	15	3256-68	2	Washer-Flat
8	116-3498	1	ASM-ROPS Pioneer	16	3296-23	2	Nut-Nyloc 1/2-13

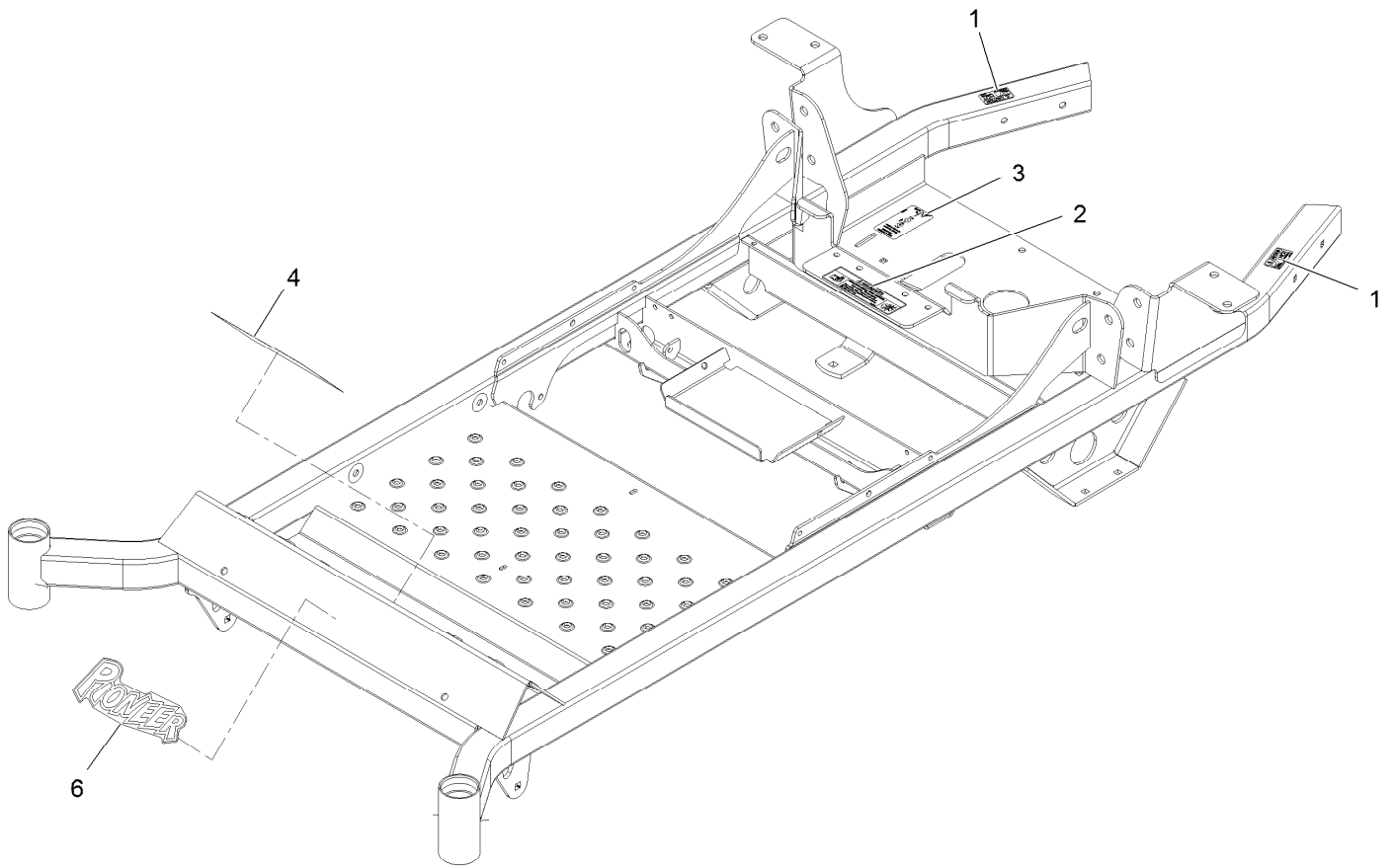

## Mainframe W/Decals Assembly No. 116-6831

<i>Ref.</i>	<i>Part Number</i>	<i>Qty.</i>	<i>Description</i>
1	103-2076	2	Decal-Caution
2	116-1119	1	Decal,Belt Drive
3	116-6363	2	Decal-Drive Release
4	116-3303	1	Decal-Slope
6	116-4570	1	Decal-Pioneer Logo



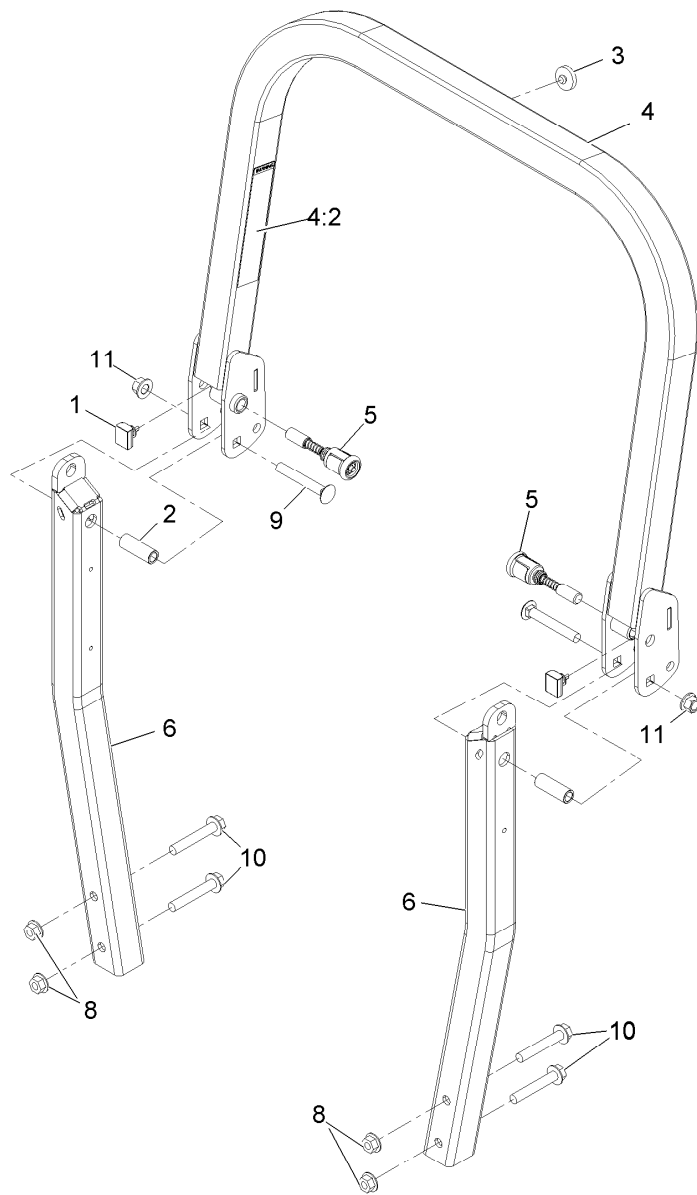

## Roll-Over Protection System Assembly No. 116-3498

Ref.	Part Number	Qty.	Description
1	109-5337	2	Bumper-ROPS
2	109-6653	2	Spacer
3	109-9233	1	Bumper-Push-In, Rubber
4	116-0019	1	Upper ROPS ASM
4:2	107-2102	1	Decal-Warning, Folding ROPS
5	116-0104	2	Pin-Spring
6		2	ASM-Lwr ROPS Leg ●
8	32128-49	4	Nut-Whizlock 1/2-13
9	3233-10	2	Bolt-Carriage 1/2-13 X 3 1/2
10	3234-40	4	Screw-HF
11	99-5107	2	Nut-Lock 1/2-13

● Not serviced separately

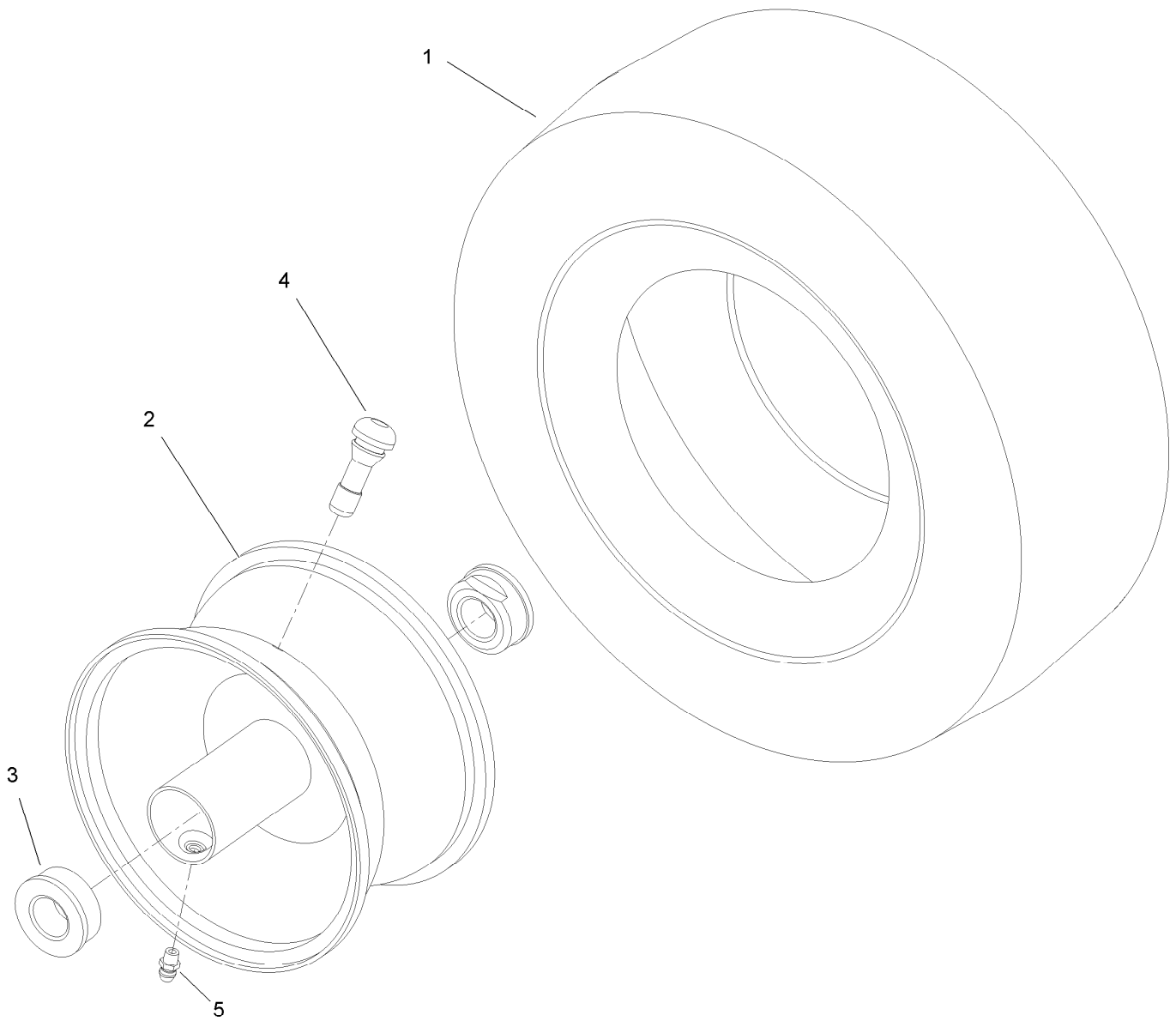

## Caster Wheel Asembly No. 120-2251

<i>Ref.</i>	<i>Part Number</i>	<i>Qty.</i>	<i>Description</i>
1	120-2252	1	Tire-13 In Smooth
2	119-3472	1	Rim-6"
3	114-1640	2	Bushing-Flange
4	232-27	1	Stem-Valve
5	302-5	1	Zerk 1/4-28 Str Thrd Forming

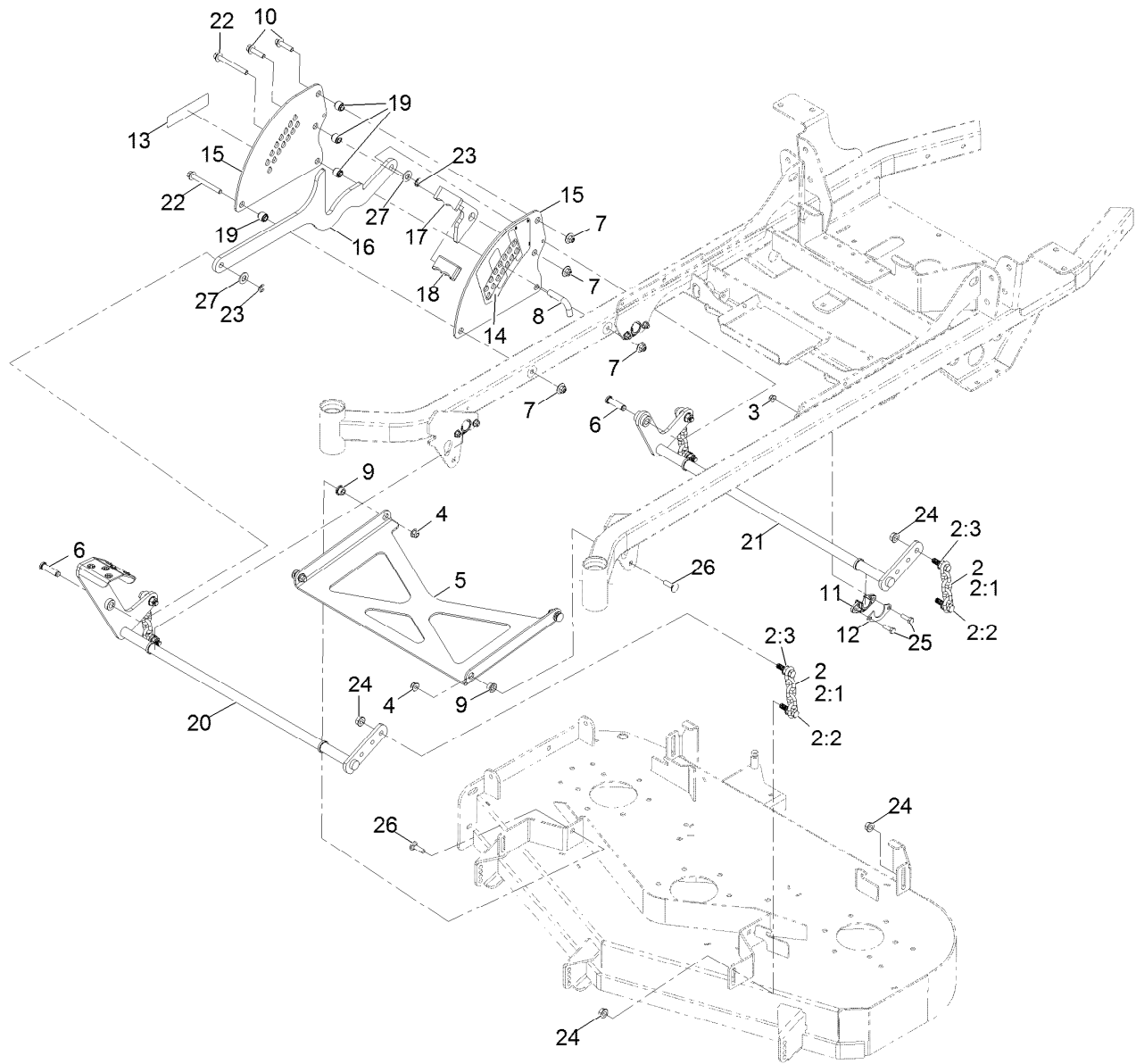

## Deck Lift Assembly

Ref.	Part Number	Qty.	Description	Ref.	Part Number	Qty.	Description
2	103-9817	4	Deck Chain ASM	13	116-3885	1	Decal-E-Series
2:1	1-633447	1	Chain-Lift, Deck	14	116-4308	1	Decal-Height Of Cut
2:2	103-1898	2	Screw-HH 7/16-20 X 1-5/8 Sp	15	116-4309-03	2	Plate,Deck Lift
2:3	32128-37	2	Nut-Whizlock 7/16-14	16	116-4310-03	1	Link-HOC
3	104-8300	8	Nut-Nyloc 5/16-18 Flg	17	116-4311	1	Transport Lock-HOC
4	104-8301	4	Nut-Nyloc 3/8-16 Flg	18	116-4312	1	Grip-Bar, Flat
5	109-3723-01	1	Strut-Deck	19	116-4313	4	Spacer-Step, Double
6	109-5819	2	Pin-Clevis	20	116-6011-03	1	Wld-Deck Lift Shaft Frt
7	109-6658	4	Nut-Nyloc 3/8-16 Flg	21	116-6012-03	1	Wld-Deck Lift Shaft Rr
8	116-5584	1	Pin-HOC	22	116-4701	2	Screw-HHF
9	109-8788	4	Bushing-Flanged	23	32120-47	2	Ring-Retaining
10	114-4681	2	Screw-HHF	24	32128-37	8	Nut-Whizlock 7/16-14
11	115-5065	4	Bushing-Flange	25	322-5	8	Screw-HH 5/16-18 X 1
12	116-2887	4	Gusset-Lift, Deck	26	3231-25	4	Bolt-Carriage 3/8-16 X 1 1/4
				27	3256-26	2	Washer-1/2 Sae

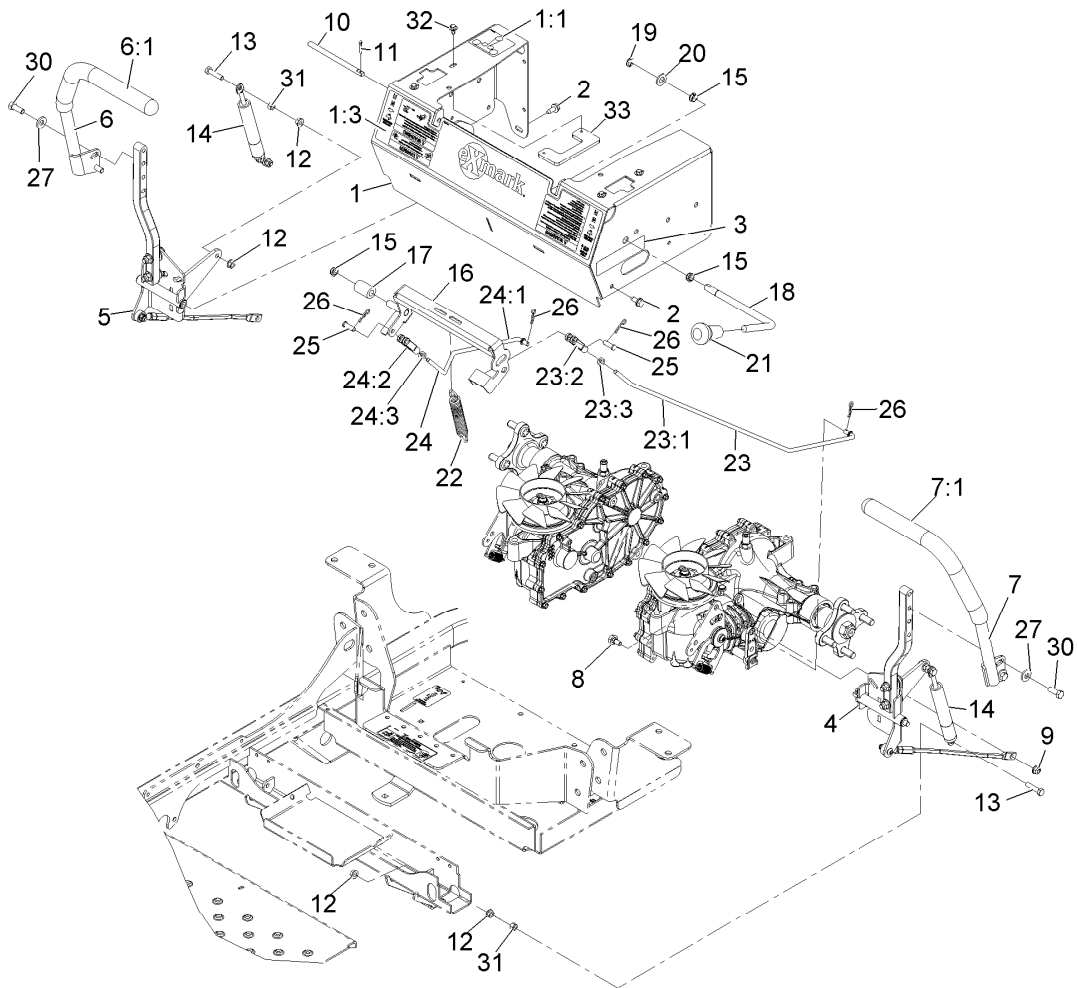

## Motion Control Assembly

Ref.	Part Number	Qty.	Description	Ref.	Part Number	Qty.	Description
1	116-3188	1	ASM-Mot Ctrl Frm W/Dcl	16	116-6233	1	Wld-Brake Center Arm
1:1	109-6014	1	Decal-Belt Routing	17	109-5010	1	Spacer
1:3	116-4430	1	Decal-Front Panel	18	116-3155	1	Handle, Brake
2	32144-70	6	Screw-HWH 5/16-18 X 3/4 Tf	19	32120-47	1	Ring-Retaining
3	116-3885	1	Decal-E-Series	20	106-9888	1	Washer-Flat
4		1	Motion Control ASM-LH ●	21	106-7952	1	Knob
5		1	Motion Control ASM-RH ●	22	88-6130	1	Spring-Deck, Engagement
6	119-3486	1	RH Handle ASM	23	116-1165	1	Brake Linkage ASM-LH
6:1	108-6187	1	Grip	23:1	116-1167	1	Linkage, Brake LH
7	119-3485	1	LH Handle ASM	23:2	1-303105	1	Yoke-Adjustable
7:1	108-6187	1	Grip	23:3	3220-2	1	Nut-Jam 5/16-24
8	37-8771	2	Screw-Shoulder 5/16-18 X 5/8	24	116-1166	1	Brake Linkage ASM-RH
9	104-8300	2	Nut-Nyloc 5/16-18 Flg	24:1	116-1168	1	Linkage-Brake, RH
10	109-3705	2	Pin-Control Pivot	24:2	1-303105	1	Yoke-Adjustable
11	3272-10	2	Pin-Cotter 1/8 X 3/4	24:3	3220-2	1	Nut-Jam 5/16-24
12	32128-20	8	Nut-Whizlock 5/16-18	25	1-808280	2	Pin-Clevis 5/16 X 1 49/64
13	1-403180	4	Screw-HH 5/16-18 X 1 1/4 Sp	26	1-806003	4	Hairpin-Cotter
14	109-5957	2	Damper-Motion Control	27	98-5975	4	Washer-Spring Disc 3/8
15	116-1393	3	Bushing, Snap	30	323-6	4	Screw-HH 3/8-16 X 1
				31	3217-6	4	Nut-Hex 5/16-18
				32	46-8560	4	Screw-HHF 1/4-20 X 1/2
				33	109-6214	2	Stop-Motion Control

● Not serviced separately

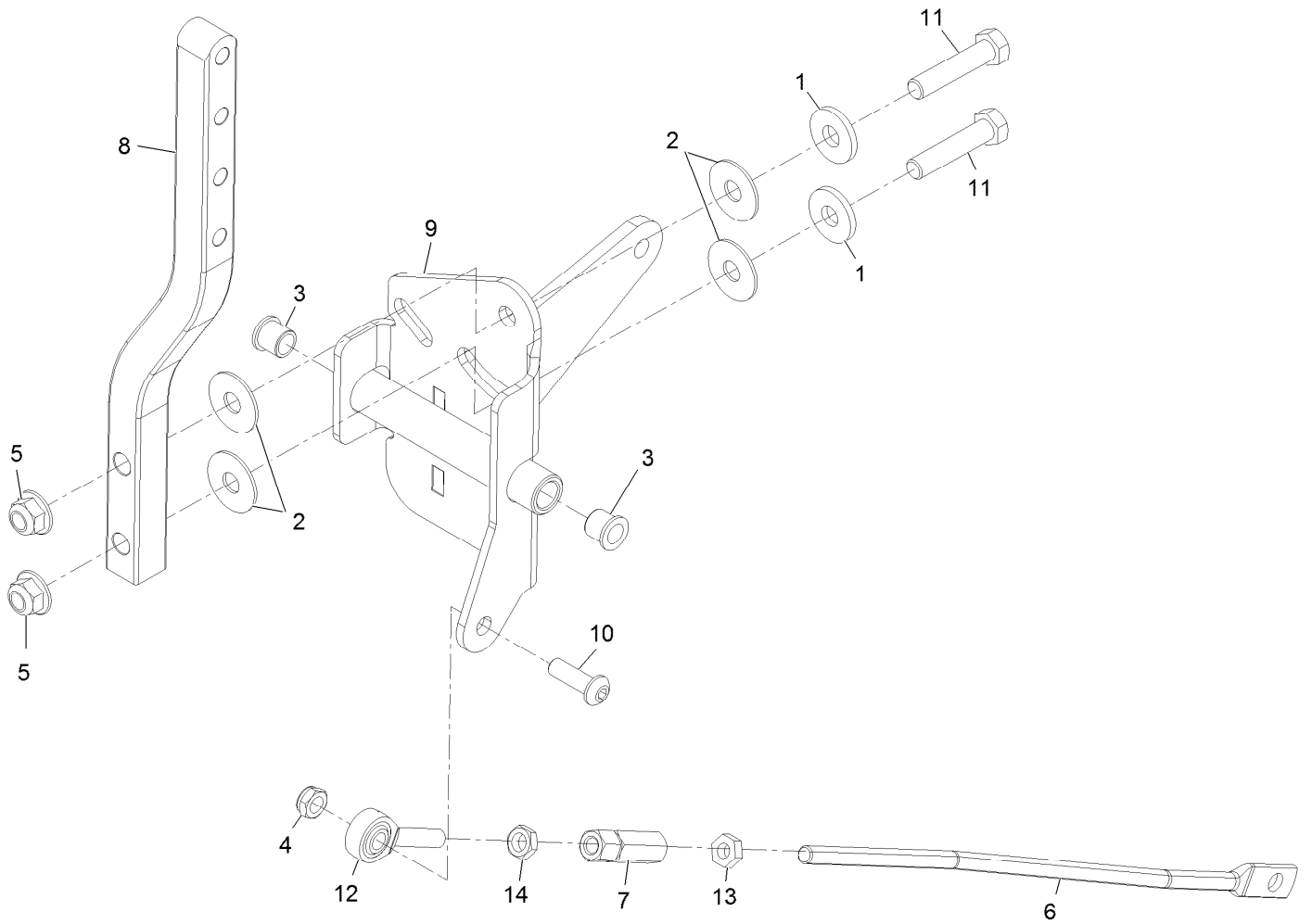

## Motion Control Assembly - LH

Ref.	Part Number	Qty.	Description
1	5-0838	2	Washer
2	52-2900	4	Washer-Plastic
3	103-9928	2	Bearing
4	3296-47	1	Nut-Nyloc 5/16-18 Thin
5	104-8301	2	Nut-Nyloc 3/8-16 Flg
6	116-2543	1	Link,Motion Control
7	109-3728	1	Nut-Rod Adjustment
8	116-3183	1	Arm-Motion Control
9	116-5477	1	LH Control Pivot ASM
10	3274-104	1	Screw-Button Head 5/16-18 X 1
11	323-9	2	Screw-HH 3/8-16 X 1 3/4
12	2411-53	1	Balljoint LH
13	3220-2	1	Nut-Jam 5/16-24
14	3220-20	1	Nut-Jam 5/16-24 LH

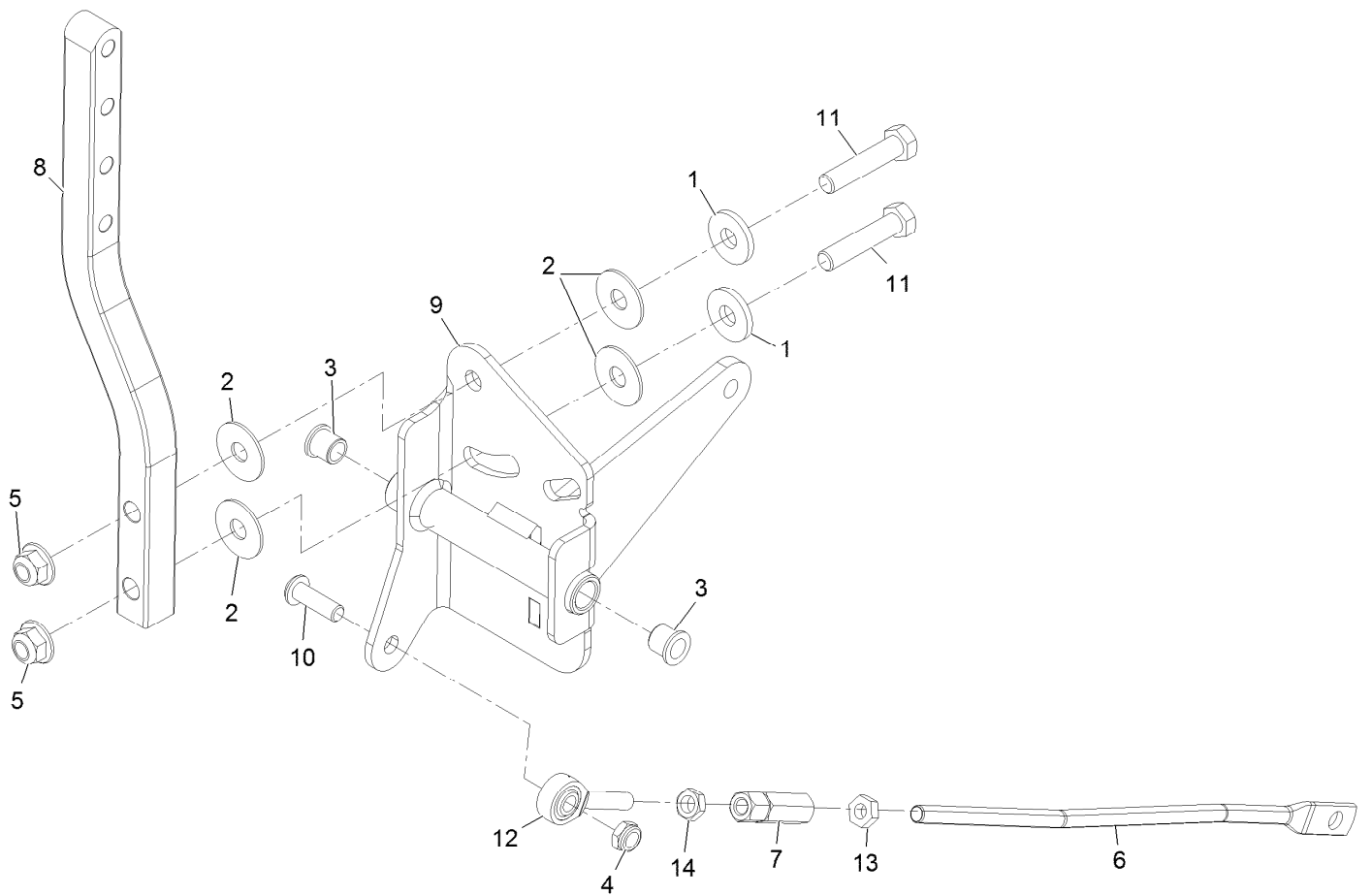

## Motion Control Assembly - RH

Ref.	Part Number	Qty.	Description
1	5-0838	2	Washer
2	52-2900	4	Washer-Plastic
3	103-9928	2	Bearing
4	3296-47	1	Nut-Nyloc 5/16-18 Thin
5	104-8301	2	Nut-Nyloc 3/8-16 Flg
6	116-2543	1	Link, Motion Control
7	109-3728	1	Nut-Rod Adjustment
8	116-3183	1	Arm-Motion Control
9	116-5476	1	RH Control Pivot ASM
10	3274-104	1	Screw-Button Head 5/16-18 X 1
11	323-9	2	Screw-HH 3/8-16 X 1 3/4
12	2411-53	1	Balljoint LH
13	3220-2	1	Nut-Jam 5/16-24
14	3220-20	1	Nut-Jam 5/16-24 LH

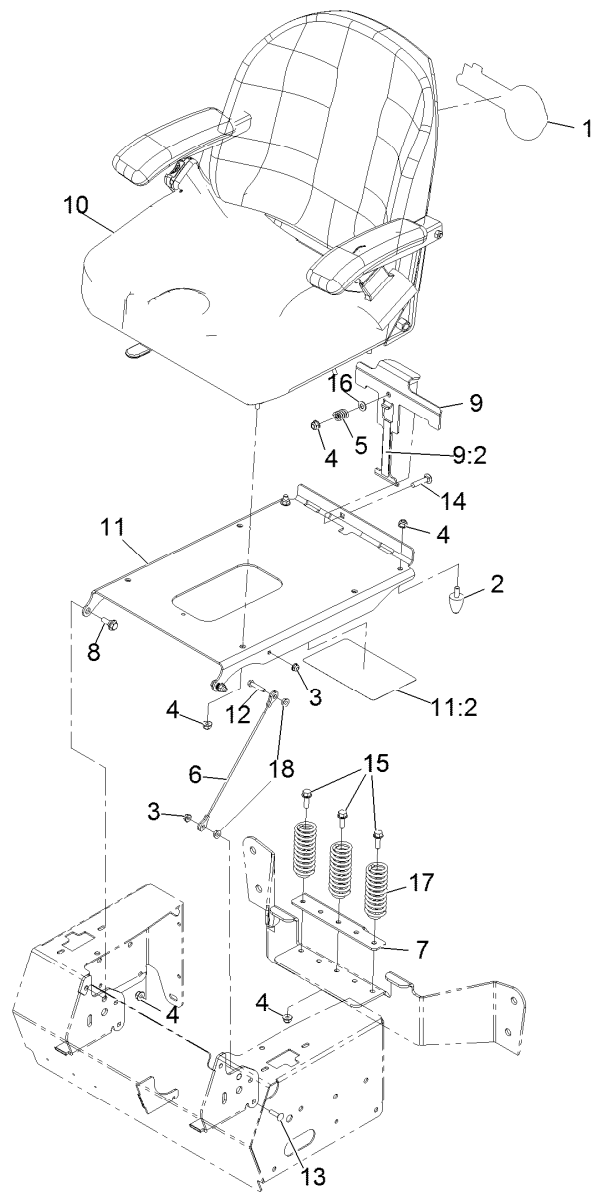

## Seat Assembly

<i>Ref.</i>	<i>Part Number</i>	<i>Qty.</i>	<i>Description</i>	<i>Ref.</i>	<i>Part Number</i>	<i>Qty.</i>	<i>Description</i>
1	103-2882	1	Decal, Exmark Logo	11	116-4418	1	Plate, Seat W/Decals
2	103-9376	2	Bumper-Seat	11:2	109-6016	1	Decal-Service Aid
3	104-7201	2	Nut-Nyloc 1/4-20 Flg	12	321-8	1	Screw-HH 1/4-20 X 1 1/4
4	104-8300	10	Nut-Nyloc 5/16-18 Flg	13	3229-2	1	Bolt-Carriage 1/4-20 X 1
5	107-3017	1	Spring-Compression	14	3230-4	1	Bolt-Carriage 5/16-18 X 1 1/2
6	109-2628	1	Cable-Stop, Seat	15	3234-29	3	Screw-HH Flg 5/16-18 X 1
7	116-0871	1	Catch,Seat Latch	16	3256-23	1	Washer-5/16 Sae
8	116-1297	2	Screw-Shoulder	17	92-7054	3	Spring-Compression
9	116-3121	1	ASM-Seat Latch	18	32128-33	2	Nut-Whizlock 1/4-20
9:2	116-3120	1	Strip-Poly Wear				
10	116-6192	1	ASM-Seat, Lze				

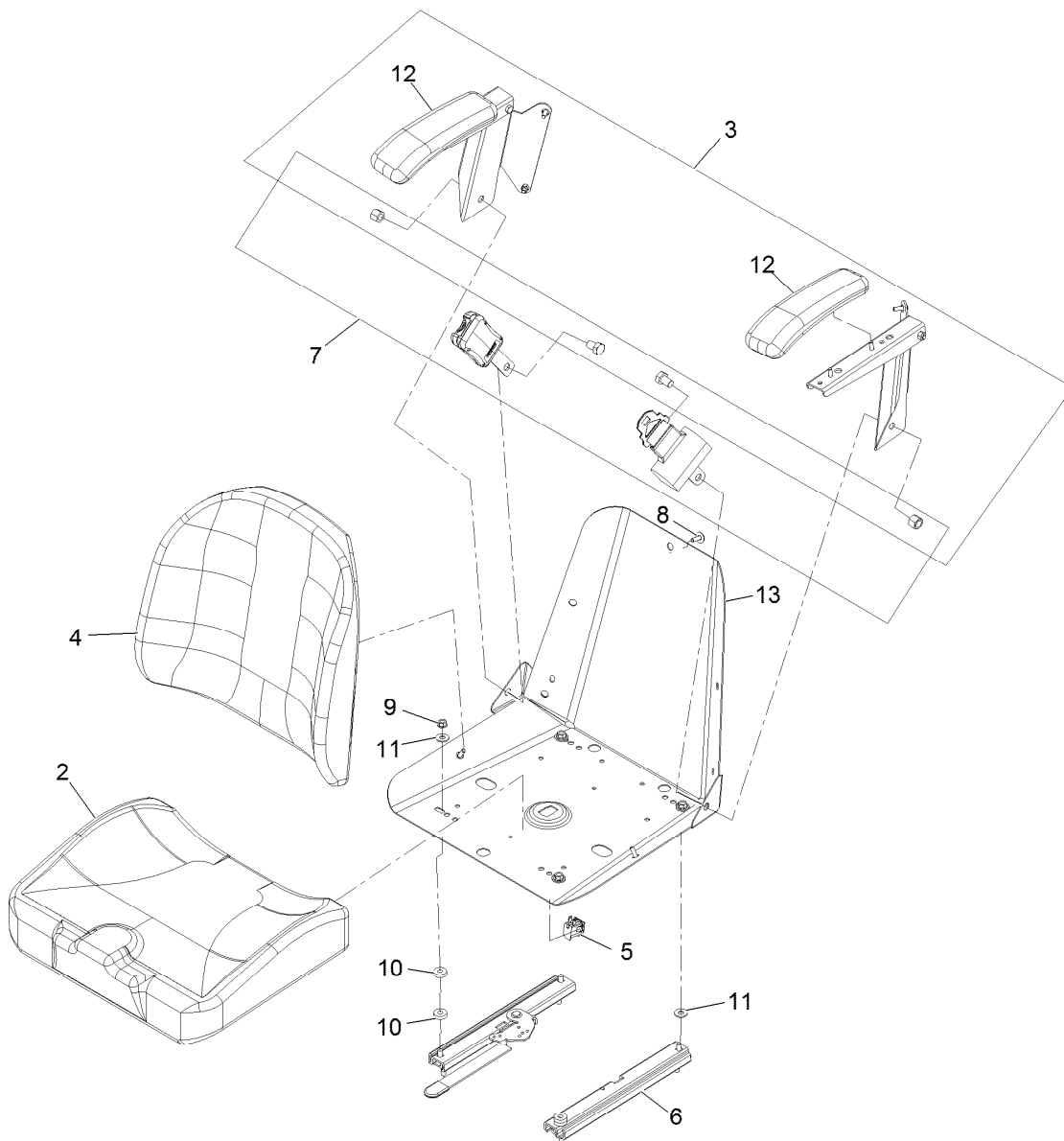

## Seat W/Tracks Assembly No. 116-6192

Ref.	Part Number	Qty.	Description
2	116-7329	1	Cushion-Seat Bottom
3	110-5719	1	Armrest Kit
4	116-3738	1	Cushion,Seat Back
5	82-2190	1	Switch
6	1-643255	1	Track-Seat
7	116-2981	1	Seat Belt Kit
8	103-8383	7	Screw-HWH 1/4-20 X 3/4 Taptite
9	32128-20	4	Nut-Whizlock 5/16-18
10	26-4840	4	Spacer-Pin, Mounting
11	3256-3	6	Washer-5/16 Std
12	110-4163	2	Cushion-Rest, Arm
13	116-7496	1	Frame-Seat



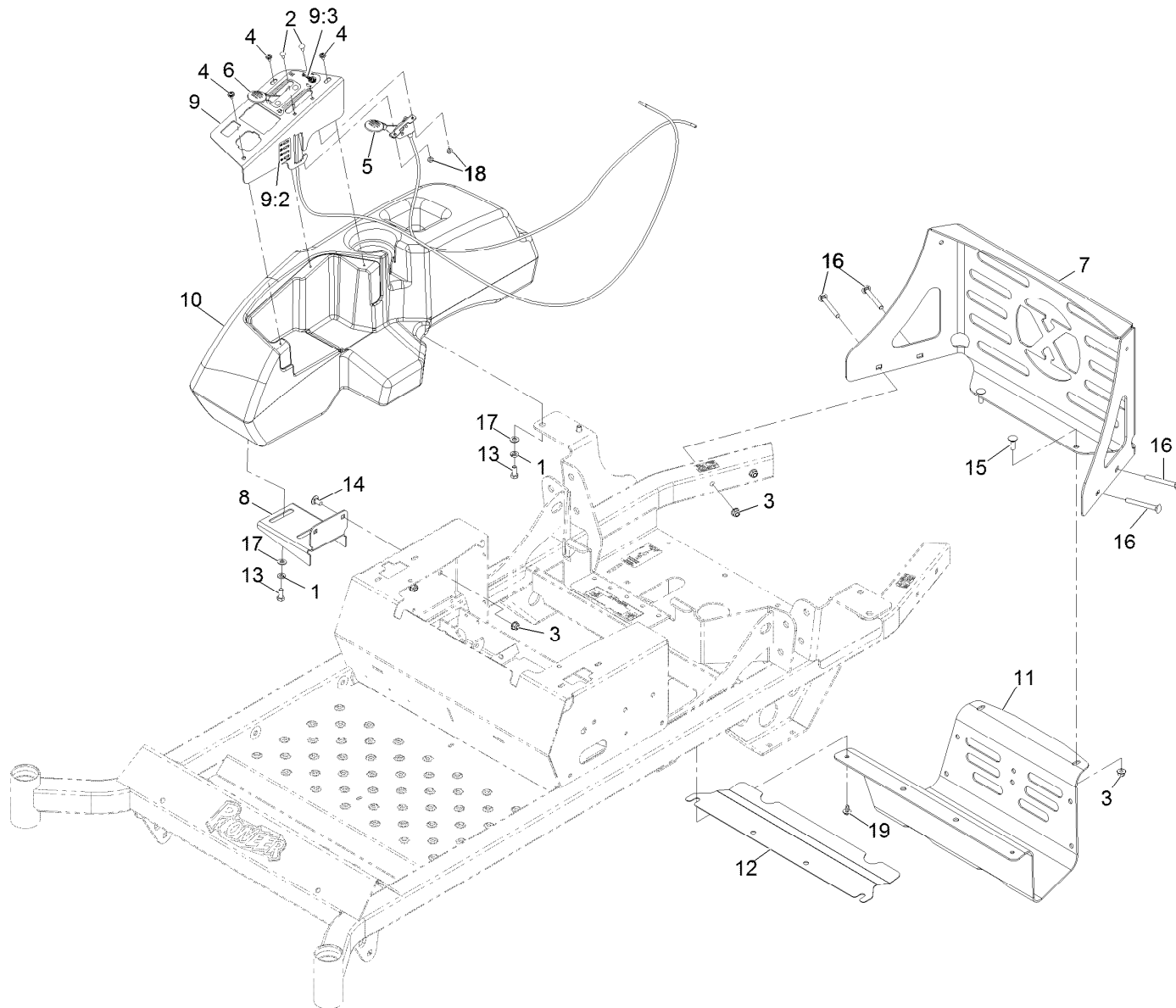

## Controls Assembly

<i>Ref.</i>	<i>Part Number</i>	<i>Qty.</i>	<i>Description</i>	<i>Ref.</i>	<i>Part Number</i>	<i>Qty.</i>	<i>Description</i>
1	1-805005	4	Washer-Lock 5/16 Heavy	10	116-4138	1	Console,RH
2	1-807513	4	Bolt-Carriage #10-24 X 1/2	11	116-4708-03	1	Guard-Muffler
3	104-8300	8	Nut-Nyloc 5/16-18 Flg	12	126-0456-03	1	Shield, Heat
4	109-2661	3	Screw-PPH #10-24 X 1/2	13	322-3	4	Screw-HH 5/16-18 X 3/4
5	116-4919	1	Control,Throttle	14	3230-18	2	Bolt-Carriage 5/16-18 X 5/8
6	109-8747	1	Control,Choke	15	3230-2	2	Bolt-Carriage 5/16-18 X 1
7	116-3453-03	1	Panel,Rear Guard	16	3230-9	4	Bolt-Carriage 5/16-18 X 2 3/4
8	116-3495-03	1	Bracket-Tank And Fender	17	3256-23	4	Washer-5/16 Sae
9	116-3496	1	ASM,Control Panel W/Decal	18	3296-2	4	Nut-Nyloc #10-24
9:2	116-1496	1	Decal,Fuse Block	19	46-8560	2	Screw-HHF 1/4-20 X 1/2
9:3	116-4465	1	Decal-Throttle Choke				

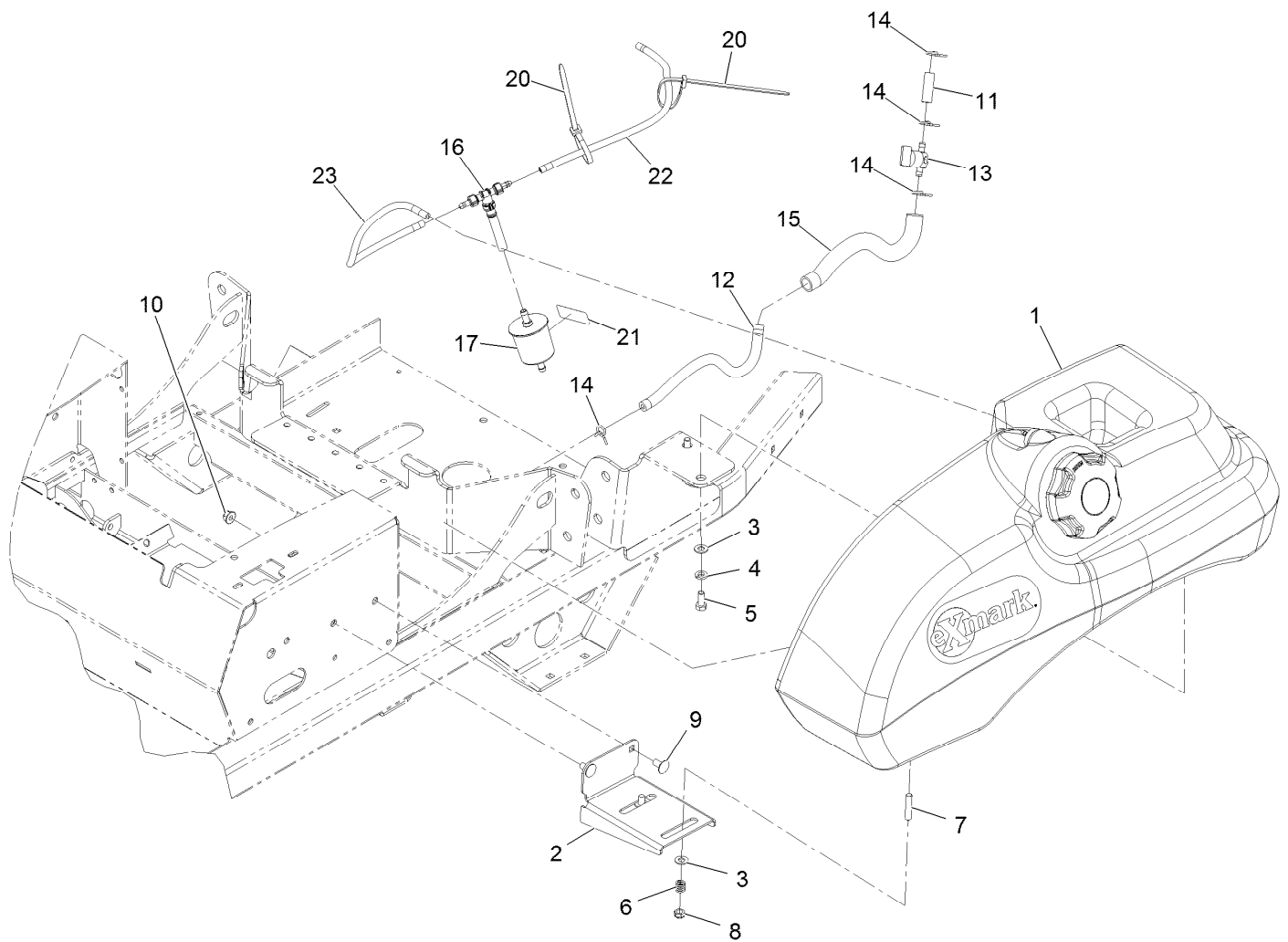

## Fuel Tank Assembly

Ref.	Part Number	Qty.	Description	Ref.	Part Number	Qty.	Description
1	116-4610	1	ASM-Fuel Tank	12	109-0282	1	Hose-Fuel
2	116-3495-03	1	Bracket-Tank And Fender	13	1-603770	1	Valve-Fuel
3	3256-23	4	Washer-5/16 Sae	14	1-303077	4	Clamp-Fuel Line
4	1-805005	2	Washer-Lock 5/16 Heavy	15	116-4515	1	Conduit-Fuel Line
5	322-3	2	Screw-HH 5/16-18 X 3/4	16	116-5464	1	Tee And Check
6	1-633349	2	Spring-Compression	17	120-2235	1	Filter-Fuel
7	1-633023	2	Stud-Fuel Tank ●	20	1-303335	2	Tie-Cable 7 15/16 (Large)
8	3296-47	2	Nut-Nyloc 5/16-18 Thin	21	116-4769	1	Decal-Filter, Emissions
9	3230-18	2	Bolt-Carriage 5/16-18 X 5/8	22	116-4800	1	Hose,Emissions
10	104-8300	2	Nut-Nyloc 5/16-18 Flg	23	116-4801	1	Hose,Emissions
11	106-9492	1	Hose-Fuel				

● Use Pro-Lock, Nut Type (P/N 1-840022, .5ml tube) on threads.

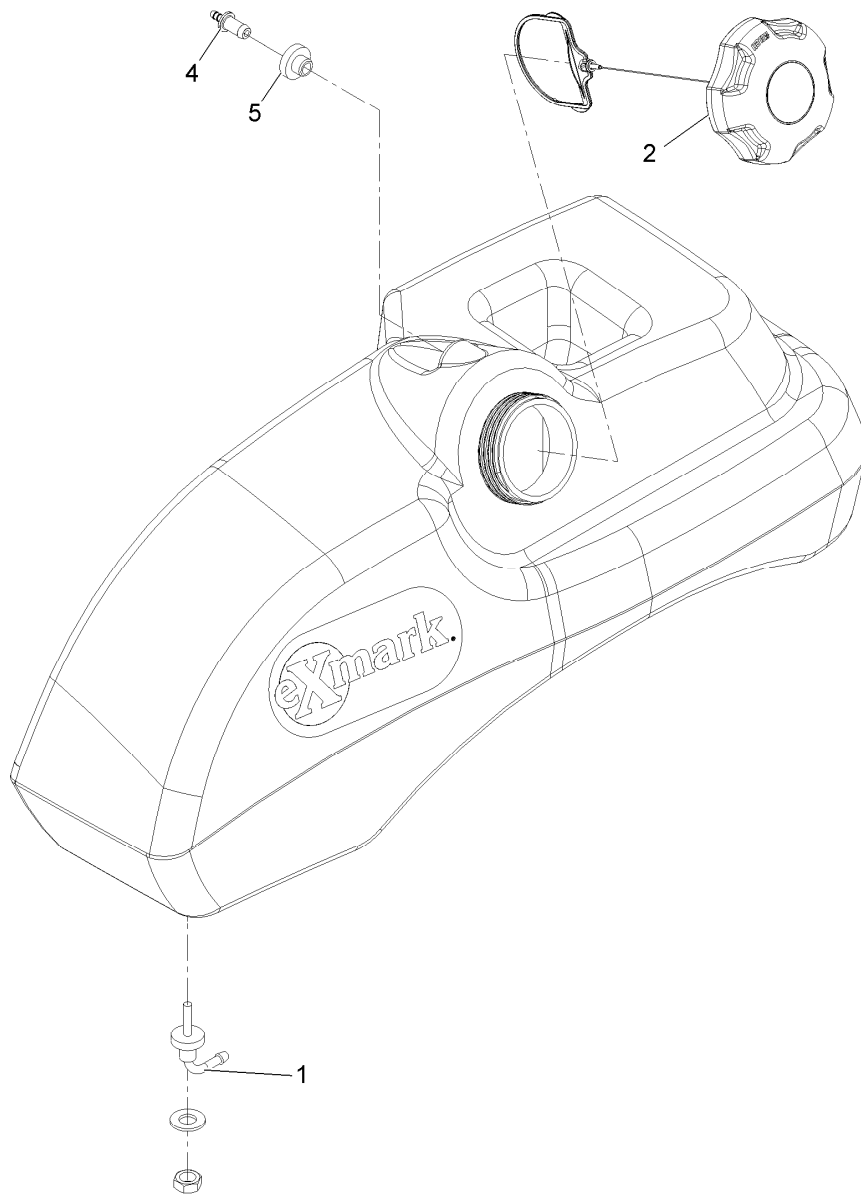

## Fuel Tank Assembly No. 116-4610

<i>Ref.</i>	<i>Part Number</i>	<i>Qty.</i>	<i>Description</i>
1	103-2605	1	Fitting-Fuel Bulkhead W/Strainer ●
2	120-5461	1	Cap-Fuel, Ratcheting
4	116-4630	1	Fitting-Straight Orifice
5	46-6560	1	Bushing

● Use Pro-Lock, Nut Type (P/N 1-840022, .5ml tube) on threads.

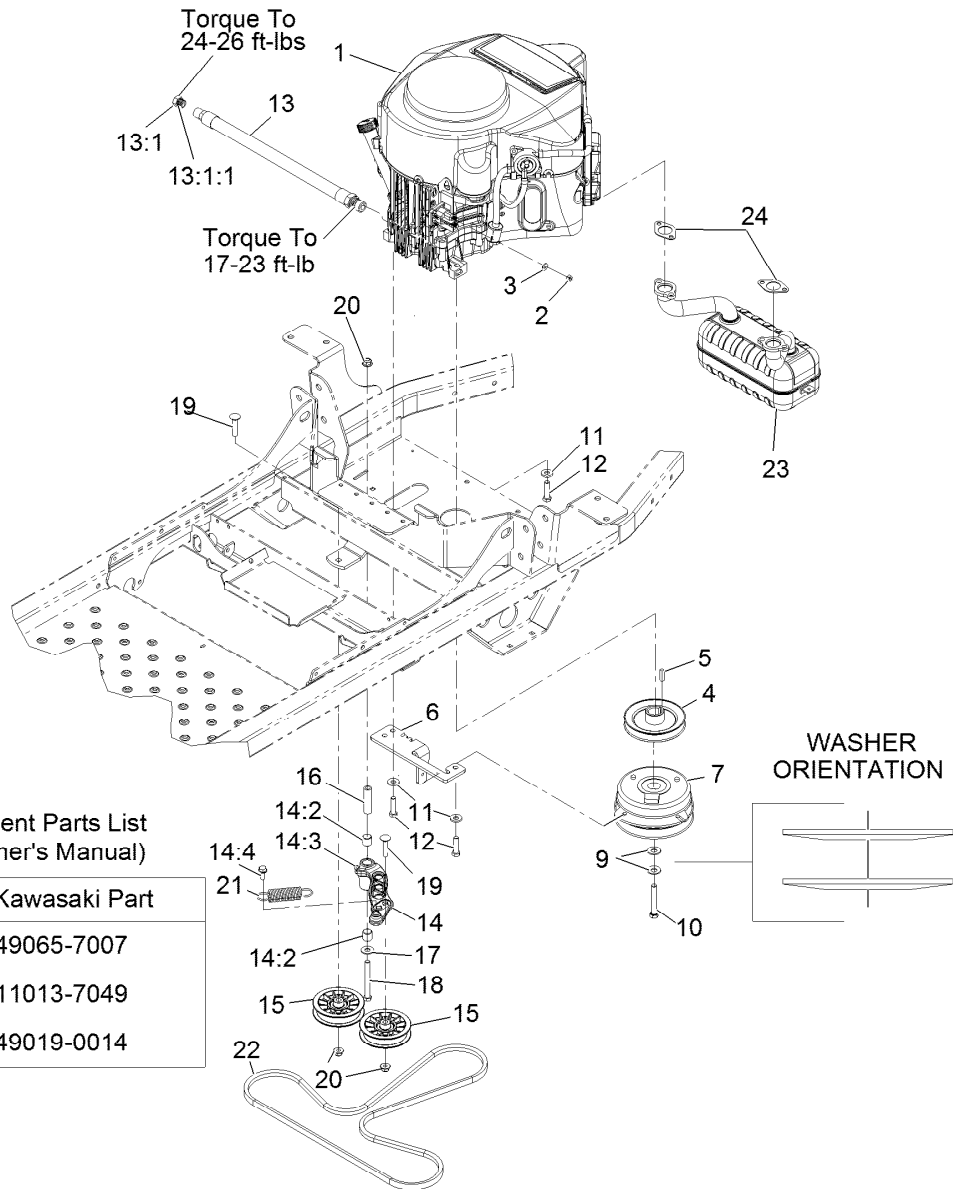

Kawasaki Replacement Parts List  
(Refer To Engine Owner's Manual)

Description	Kawasaki Part
Engine Oil Filter	49065-7007
Engine Air Filter	11013-7049
Fuel Filter	49019-0014

## Engine Assembly

Ref.	Part Number	Qty.	Description
1		1	Engine-Kawasaki ●■
2	3217-5	1	Nut-Hex 1/4-20
3	3256-22	1	Washer-1/4 Sae
4	109-3386	1	Sheave-Split Steel
5	1-807259	1	Key-Machine 1/4 X 1/4 X 1
6	116-4773-03	1	Anchor-Clutch
7	116-5059	1	Clutch, 125Ftlb 1.0 B
9	1-603610	2	Washer-Spring Disc 7/16
10	116-1066	1	Screw-HH 7/16-20 X 2 3/4 W/Loctite ◆
11	98-5975	4	Washer-Spring Disc 3/8
12	323-8	4	Screw-HH 3/8-16 X 1 1/2
13	116-4924	1	Asm-Hose Oil Drain W/Plug ▲
13:1	353-508	1	Plug-W/O-Ring
13:1:1	237-42	1	O-Ring

Ref.	Part Number	Qty.	Description
14	126-0973	1	ASM-Idler Arm W/Bearings
14:2	1-513034	2	Sleeve-Bearing
14:3	302-40	1	Zerk-90° 1/4-28
14:4	32144-11	1	Screw-HWH 5/16-18 X 3/4 Tf
15	116-2456	2	Pulley-Flat, 3.50 Dia
16	1-603384	1	Bushing-Pivot, Idler
17	3256-4	1	Washer-3/8 Std
18	323-15	1	Screw-HH 3/8-16 X 3 1/2
19	3231-5	2	Bolt-Carriage 3/8-16 X 1 3/4
20	104-8301	3	Nut-Nyloc 3/8-16 Flg
21	1-603402	1	Spring-Extension
22	115-9613	1	V-Belt
23	117-7256	1	Muffler-Kawasaki
24	1-653313	2	Gasket-Exhaust

● Not serviced separately

▲ Use a Teflon Pipe Sealant or equivalent on threads.

◆ Use Pro-Lock, Nut Type (P/N 1-840022, .5ml tube) on threads.

■ Obtain parts from [www.kawpowerepc.com](http://www.kawpowerepc.com)

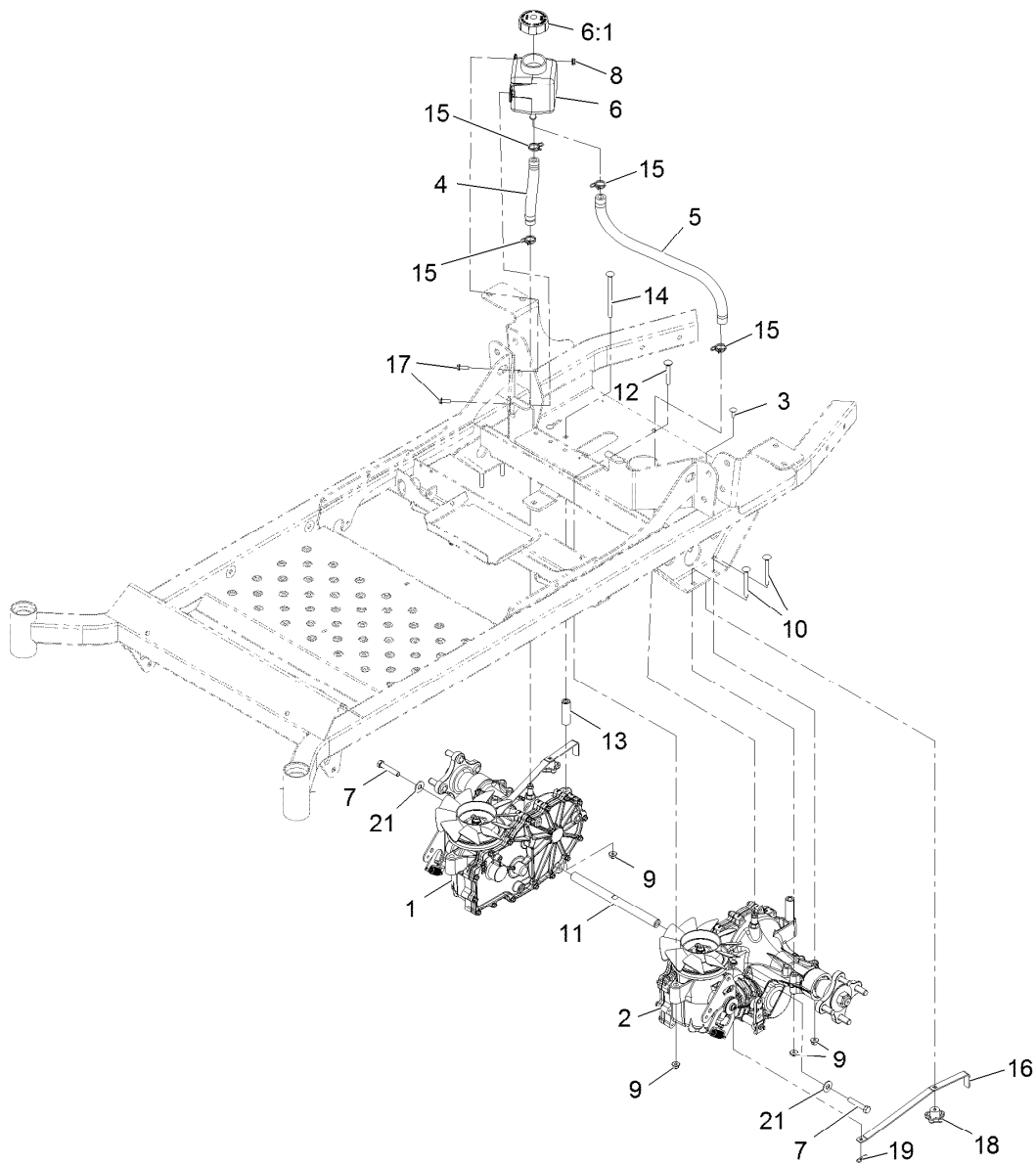

## Hydraulic Assembly

Ref.	Part Number	Qty.	Description	Ref.	Part Number	Qty.	Description
1	116-4544	1	Transaxle ASM	11	116-6833	1	Shaft-Spacer
2	116-4545	1	Transaxle ASM	12	3230-7	2	Bolt-Carriage 5/16-18 X 2 1/4
3	3229-1	2	Bolt-Carriage 1/4-20 X 3/4	13	116-5809	2	Spacer-Hydro
4	116-5641	1	Hose-Hydraulic	14	3230-30	2	Bolt-Carriage 5/16-18 X 4 1/2
5	116-5642	1	Hose-Hydraulic	15	126-0327	4	Clamp-Hose
6	109-2250	1	Vent-Tank, Hydro	16	109-5395	2	Arm-Hydro Bypass
6:1	109-3320	1	Cap-Reservoir, HYD	17	32105-15	2	Screw-Machine 1/4-20 X 3/4
7	94-7972	2	Screw-HH W/Loctite ●	18	108-6402	2	Knob-Handle
8	104-7201	2	Nut-Nyloc 1/4-20 Flg	19	1-806003	2	Hairpin-Cotter
9	104-8300	8	Nut-Nyloc 5/16-18 Flg	21	3256-4	2	Washer-3/8 Std
10	3230-9	4	Bolt-Carriage 5/16-18 X 2 3/4				

● Use Pro-Lock, Nut Type (P/N 1-840022, .5ml tube) on threads.

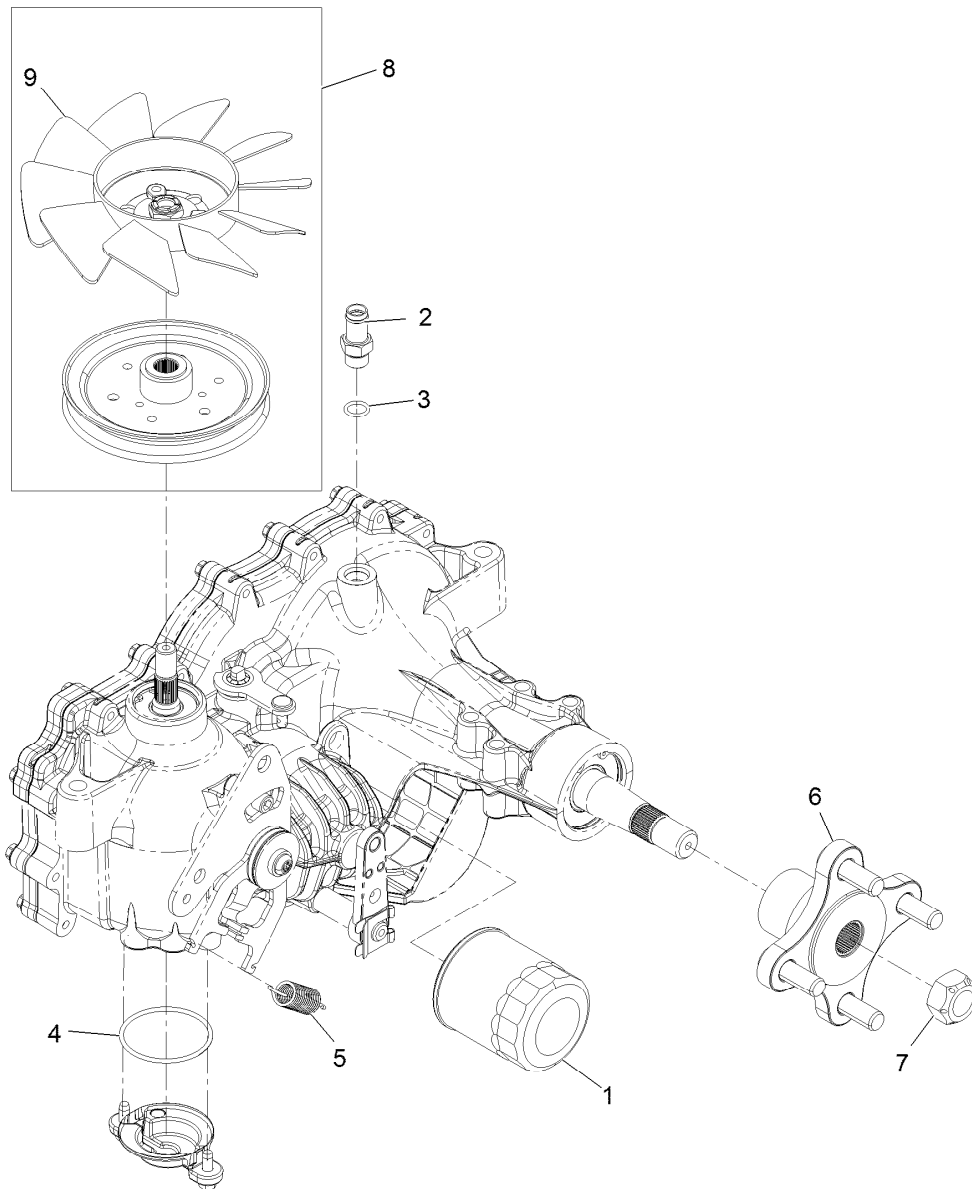

## Transaxle Assembly

<b>Ref.</b>	<b>Part Number</b>	<b>Qty.</b>	<b>Description</b>
1	109-3321	1	Element-Oil Filter, HYD
2	109-3278	1	Adapter-Straight
3	237-42	1	O-Ring
4	109-3540	1	O Ring-Seal
5	109-5592	1	Spring-Extension
6	109-5939	1	Hub Kit
7	109-3536	1	Nut-Hub
8	109-5938	1	Fan And Pulley Kit
9	114-8453	1	Fan-7.0
99	109-3537	1	Complete Seal Kit ●

● Not illustrated

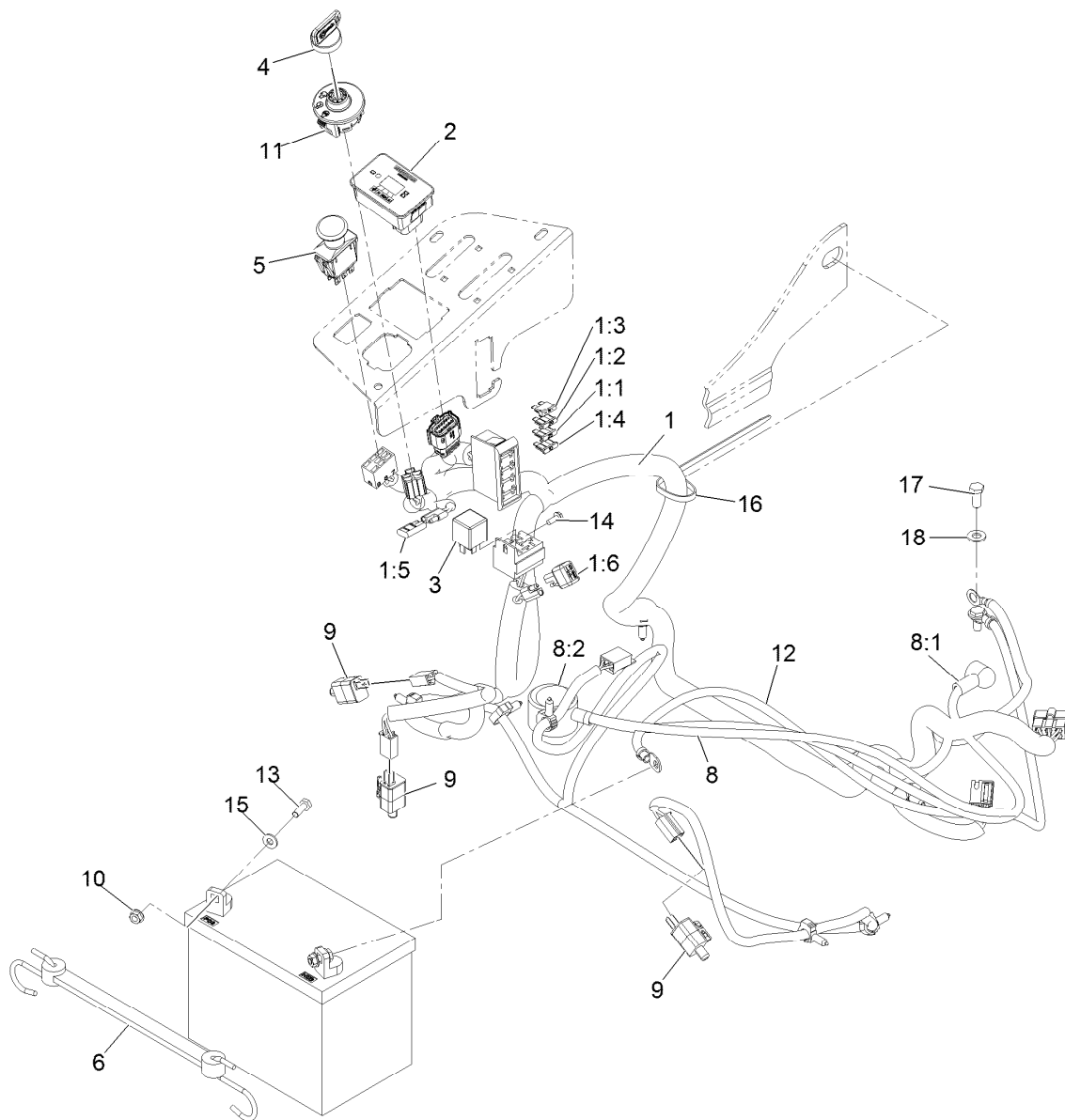

## Electrical Assembly

Ref.	Part Number	Qty.	Description
1	116-4861	1	Harness, Wire ●
1:1	109102	1	Fuse-Blade, 25 Amp
1:2	1-816001	1	Fuse-Blade Type, 20 Amp
1:3	109355	1	Fuse-Blade, 15 Amp
1:4	218-578	1	Fuse-Blade, 10 Amp
1:5	116-0053	1	Cap-Plug
1:6	103-3895	1	Diode-Tvs
2	116-5609	1	Module ASM
3	1-643275	1	Relay-12Vdc 40 Amp
4	1-603511	1	Key-Ignition
4	103-2106	1	Key-Exmark Logo
5	103-5221	1	Switch-PTO
6	104-2466	1	Holddown-Battery
8	109-7621	1	Positive Battery Cable ASM

Ref.	Part Number	Qty.	Description
8:1	1-543393	1	Insulator-Solenoid
8:2	109-2407	1	Insulator-Battery
9	110-6765	3	Switch-Single Pole No
10	32128-33	2	Nut-Whizlock 1/4-20
11	117-2221	1	Switch-Ignition
12	117-7240	1	Cable-Battery, Negative
13	321-4	2	Screw-HH 1/4-20 X 3/4
14	32144-1	1	Screw-HWH #10-24 X 1/2 TapTite
15	3256-22	2	Washer-1/4 Sae
16	1-303335	1	Tie-Cable 7 15/16 (Large)
17	33114-020	1	Screw-HH M8-1.25 X 20Mm
18	33094-00	1	Washer

● Use dielectric grease on all unsealed connectors and terminals only. Do not apply in sealed connectors.

**Notes:**



**Notes:**

**Notes:**

# EXMARK® MAINTENANCE

## MAXIMIZE THE PERFORMANCE OF YOUR EXMARK.

### **4-CYCLE PREMIUM ENGINE OIL**

Part No. 116-3373

Both SAE 30 and SAE 10W-30 in one bottle.

Contains increased levels of zinc and phosphorus for better lubricity.

No Viscosity Index Improvers that tend to shear down in high heat.

Synthetic formulation.

Gas & Diesel compatible.

Anti-corrosion additives.

API 'SL' and JASO rated with wet clutch compatibility for other machines.

### **PREMIUM HYDRO OIL**

Part No. 109-9828

Commercial quality for tough, high-heat conditions.

Designed specifically for zero-turn mower hydraulic systems.

Superior shear resistance under heavy loads.

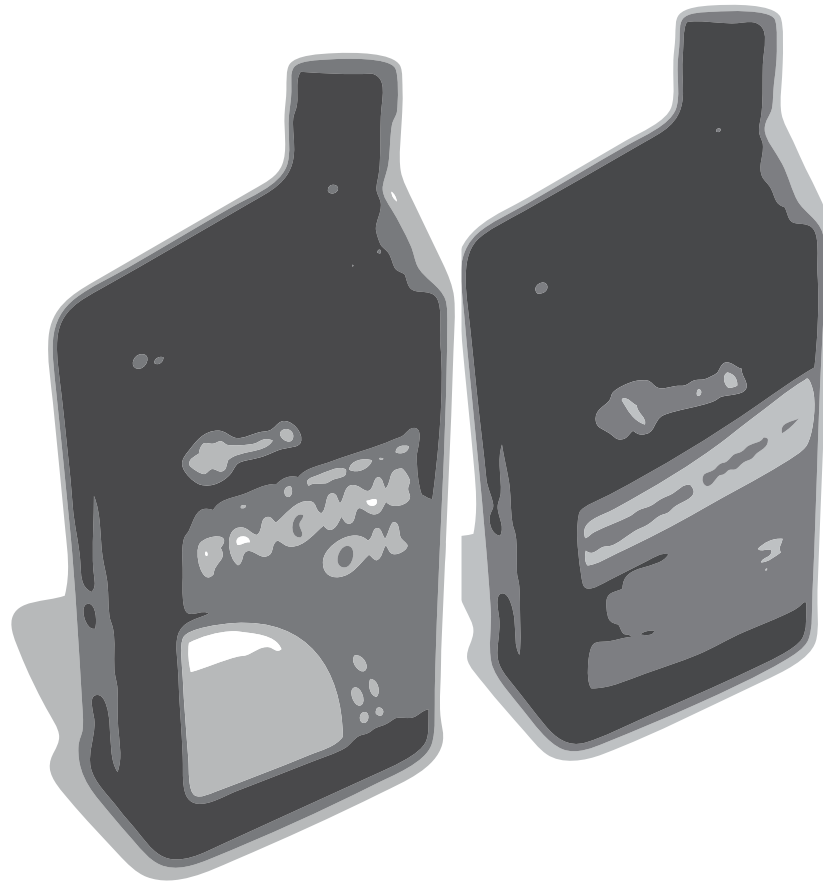

Available from your local Exmark dealer. Find your closest dealer at [exmark.com](http://exmark.com)

## EXMARK ACCESSORIES AND OPTIONS\*

### MID-MOUNT RIDING ACCESSORIES AND OPTIONS

CUSTOM RIDE SEAT SUSPENSION SYSTEM	OPERATOR CONTROLLED DISCHARGE
FULL SUSPENSION SEAT	SUN SHADE
DECK LIFT ASSIST KIT	TRASH CONTAINER
HITCH KIT	TURF STRIPER
LIGHT KIT	ULTRA VAC COLLECTION SYSTEM
12V POWER PORT	ULTRA VAC QUICK DISPOSAL SYSTEM
MICRO-MULCH SYSTEM	

### OUT-FRONT RIDING ACCESSORIES AND OPTIONS

CUSTOM RIDE SEAT SUSPENSION SYSTEM	SNOW BLADE
DUAL-TAIL WHEEL	SNOWBLOWER
FLOOR PAN EXTENDER	SUN SHADE
HITCH KIT	TRASH CONTAINER
LIGHT KIT	ULTRA VAC COLLECTION SYSTEM
MICRO-MULCH SYSTEM	ULTRA VAC QUICK DISPOSAL SYSTEM
ROLL OVER PROTECTION SYSTEM (ROPS)	WEATHER CAB

### WALK-BEHIND ACCESSORIES AND OPTIONS

GRASS CATCHER	TURF STRIPER
MICRO-MULCH SYSTEM	STANDON

\*Some accessories and options not available for some models.

Place Model No. and Serial No.  
Label Here (Included in the Literature  
Pack) or Fill in Below

Model No. \_\_\_\_\_

Serial No. \_\_\_\_\_

Date Purchased \_\_\_\_\_

Engine Model No. and Spec. No. \_\_\_\_\_

Engine Serial No. (E/No) \_\_\_\_\_

© 2014 Exmark Mfg. Co., Inc.  
Industrial Park Box 808  
Beatrice, NE 68310  
All Rights Reserved

Part No. 4501-716 Rev. A  
(402) 223-6285  
Fax (402) 223-5489  
Printed in the USA.

