

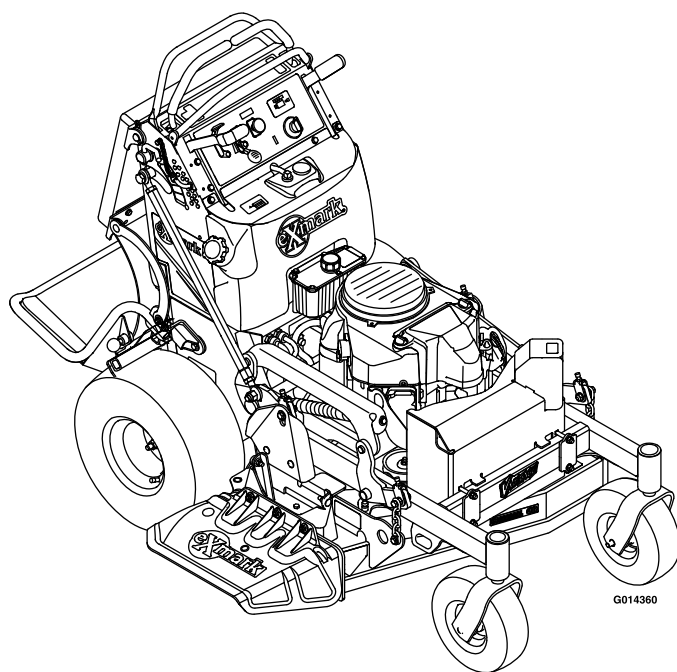

VANTAGE® S-SERIES

Model No. VTS541KA363—Serial No. 31400000 and Up

Picture below may not reflect actual product.



Parts Manual

Part No. 4501-807 Rev. A

Ordering Replacement Parts

To order replacement parts, please supply the part number, the quantity, and the description of each part desired.

Understanding Reference Numbers

Each identified part in an illustration has a reference number. The reference number for a part also appears in the parts list, along with other information about the part.

This catalog uses two special reference number formats, one to indicate parts in a service assembly and another to indicate the quantity of a given part in an illustration.

Service Assembly Reference Numbers

Parts in service assemblies have reference numbers in the form a:b. The a represents the reference number of the entire service assembly and the b represents a sequential number unique to each part within the service assembly.

For example, a wheel assembly might be identified by reference number 6, the tire by 6:1, the valve by 6:2, and the wheel by 6:3. When you order the assembly identified by reference number 6, you receive all parts identified by reference numbers 6:1, 6:2, and 6:3. However, you may also order any part individually. Reference numbers of this type appear in illustration and in parts lists.

Reference Numbers Indicating Quantity

In an illustration, if a reference number indicates more than one part, the reference number has the form nX y. The n represents the quantity of the part, the X is the multiplication symbol, and the y represents the reference number.

For example, in an illustration, the reference number 2X 37 means that two of the parts identified by reference number 37 are indicated.

List of Abbreviations

| | | |
|--|--|--|
| AR: as required | HJ: hex jam | PRH: phillips round head |
| ASM: assembly | HLH: hex lag head | PTH: phillips truss head |
| BBC: blade brake control | HOC: height-of-cut | PTO: power-take-off |
| BHTF: button head thread forming | HSBH: hex socket button head | RH: right hand |
| CARR: carriage | HSFH: hex socket flat head | ROPS: roll-over protection system |
| CCW: counter clockwise | HSH: hex socket head | RRB: rear roller brush |
| CW: clockwise | HWH: hex washer head | SFH: slotted fillister head |
| DEG: degrees | HWHTF: hex washer head thread forming | SHH: slotted hex head |
| DPA: Dual Point Adjustment | HYD: hydraulic | SHWH: slotted hex washer head |
| ECM: electronic control module | LH: left hand | SPH: slotted pan head |
| EXT: external | LP: Liquefied Petroleum Gas | SQH: square head |
| FH: flat head | LPG: Liquefied Petroleum Gas | SRH: slotted round head |
| GA: gauge | NI: nylon insert | STD: standard |
| HD: heavy-duty | NPTF: national pipe thread fine | TAP: self tapping |
| HF: hex flange | PFH: phillips flat head | TTH: torx truss head |
| HH: hex head | PPH: phillips pan head | |
| HHF: hex head flange | PPHTF: phillips pan head thread forming | |
| HHFTF: hex head flange thread forming | | |

Touch Up Paint

Exmark black touch up spray paint – gloss black.

Exmark red touch up paint (spray paint – P/N 1-850337 - .6 oz liquid bottle – P/N 103-9140).



If your Exmark dealer does not have the Exmark part in stock, Exmark will get the parts to the dealer the next business day or the part will be FREE Guaranteed!! (Some restrictions apply. See your participating Exmark Dealer for details.)

Contents

| | |
|--|----|
| Complete Deck Assembly..... | 4 |
| Deck Assembly..... | 5 |
| Deck W/Decals Assembly No. 116-3662..... | 6 |
| Idler Arm Assembly No. 116-3680..... | 7 |
| Main Frame Assembly..... | 8 |
| Control Tower W/Decals Assembly No. 116-6323..... | 9 |
| Wheel and Bearing Assembly No. 112-3810..... | 10 |
| Park Brake Assembly..... | 11 |
| Brake Linkage Assembly No. 116-4166..... | 12 |
| Deck Lift Assembly..... | 13 |
| Height of Cut Link Assembly No. 116-3975..... | 15 |
| Platform Assembly..... | 16 |
| Cushion Assembly No. 126-1210..... | 17 |
| Platform Assembly No. 116-3523..... | 18 |
| Ground Drive Assembly..... | 19 |
| Pump Idler Assembly No. 116-9980..... | 21 |
| Control Assembly..... | 22 |
| Vertical Adjust Link Assembly No. 116-4210..... | 23 |
| LH Tracking Control Linkage Assembly No. 116-4213..... | 24 |
| RH Tracking Control Linkage Assembly No. 116-4214..... | 25 |
| Engine Assembly..... | 26 |
| Fuel Tank Mounting Assembly..... | 27 |
| Fuel Tank Assembly No. 116-4577..... | 28 |
| Electrical Assembly..... | 29 |

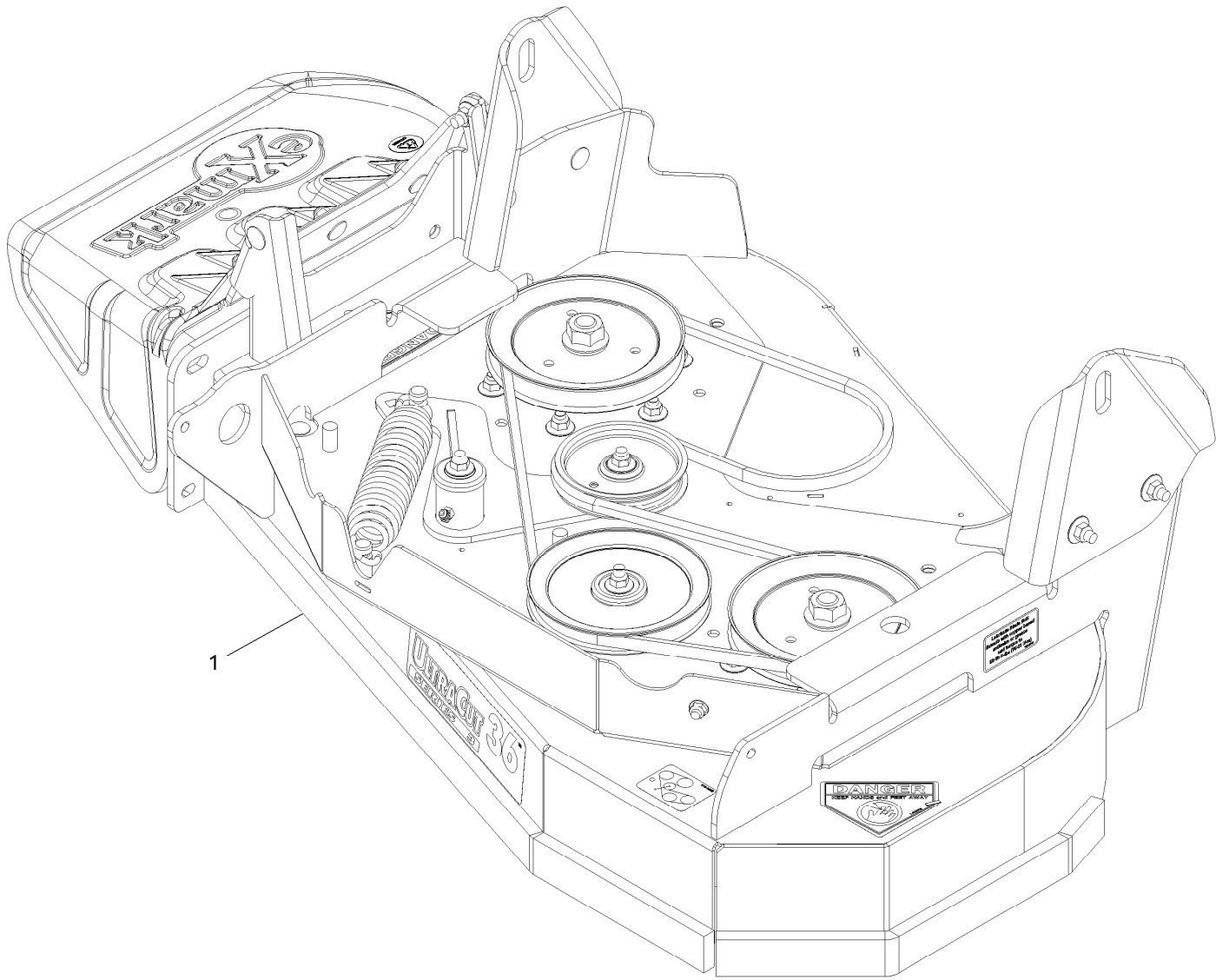

Complete Deck Assembly

| <i>Ref.</i> | <i>Part Number</i> | <i>Qty.</i> | <i>Description</i> |
|-------------|--------------------|-------------|-----------------------|
| 1 | 116-4301 | 1 | ASM,Deck Complete 363 |

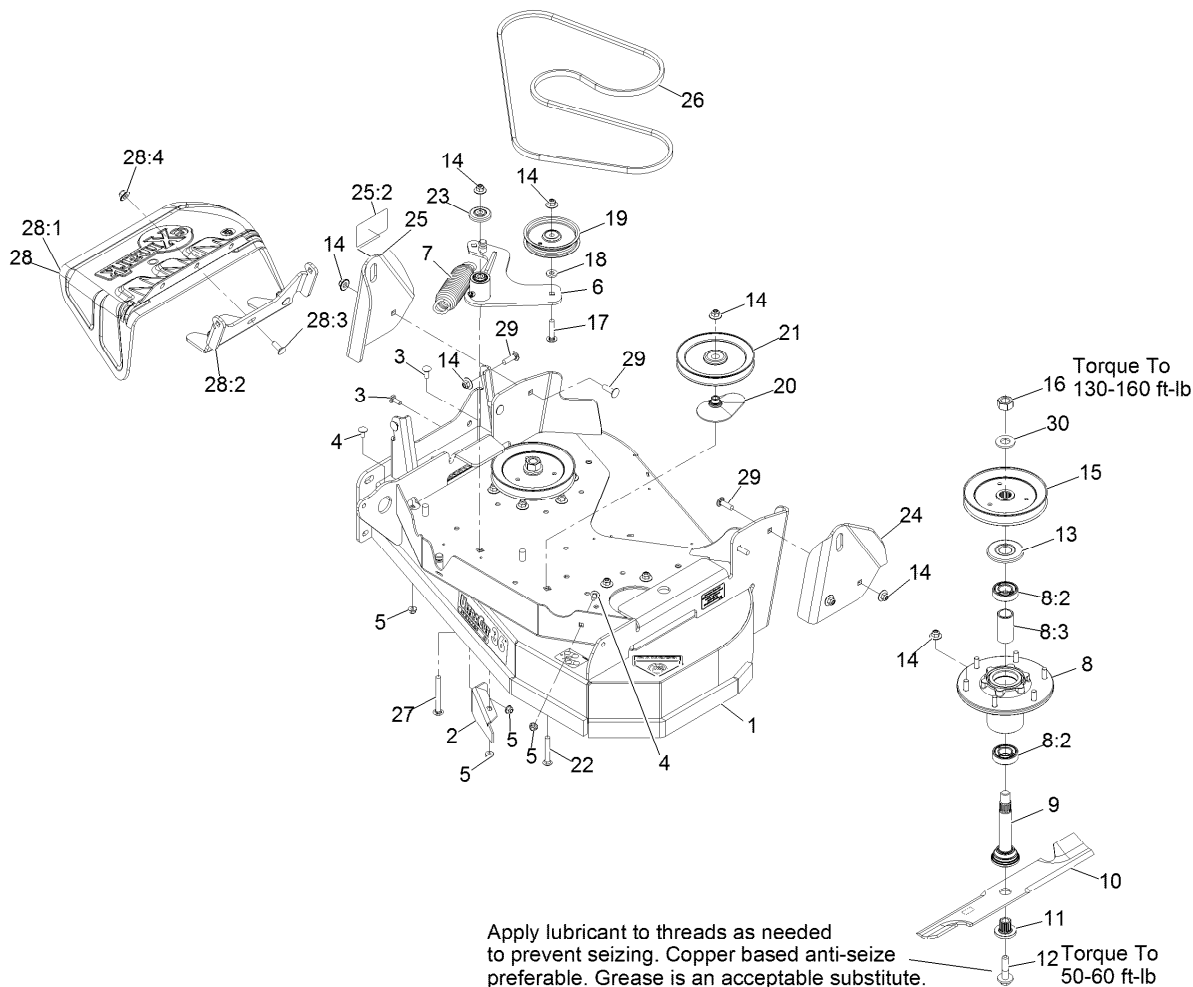

Deck Assembly

| Ref. | Part Number | Qty. | Description | Ref. | Part Number | Qty. | Description |
|------|-------------|------|------------------------------|------|-------------|------|---------------------------------------|
| 1 | 116-3662 | 1 | Deck ASM - 36 | 16 | 116-7306 | 2 | Nut-Hex |
| 2 | 116-4244-01 | 1 | Baffle-Dogleg | 17 | 3231-5 | 1 | Bolt-Carriage 3/8-16 X 1 3/4 |
| 3 | 3230-16 | 2 | Bolt-Carriage 5/16-18 X 7/8 | 18 | 43-0940 | 1 | Spacer |
| 4 | 3230-18 | 2 | Bolt-Carriage 5/16-18 X 5/8 | 19 | 93-1622 | 1 | Pulley-Idler |
| 5 | 104-8300 | 4 | Nut-Nyloc 5/16-18 Flg | 20 | 109-2872 | 1 | Spacer-Pulley |
| 6 | 116-3680 | 1 | Idler Arm ASM - | 21 | 116-3592 | 1 | Pulley-Idler |
| 7 | 116-6317 | 1 | Spring-Extension | 22 | 3231-31 | 1 | Bolt-Carriage 3/8-16 X 2 1/2 |
| 8 | 116-3344 | 2 | ASM-Cutter Hsg With Bearings | 23 | 103-2916 | 1 | Guard-Top |
| 8:2 | 116-0720 | 2 | Bearing-Ball | 24 | 116-3675-01 | 1 | Push-Tower,LH 36 |
| 8:3 | 116-3312 | 1 | Spacer-Bearing | 25 | 116-4674 | 1 | Push Tower-RH 36, W/Decal |
| 9 | 116-3342 | 2 | ASM-Spindle And Seal ■ | 25:2 | 1-303508 | 1 | Decal-Warning, Discharge |
| 10 | 103-6382 | 2 | Blade, Solid | 26 | 116-3703 | 1 | Belt-V |
| 10 | 103-6387 | 2 | Blade, Low Lift | 27 | 116-1502 | 1 | Bolt-Carriage Shoulder 3/8-16 X 3 1/2 |
| 10 | 103-6392 | 2 | Blade, Mulching ● | 28 | 116-4230 | 1 | Chute - Discharge ASM |
| 10 | 103-6397 | 2 | Blade, Extreme | 28:1 | 109-2738 | 1 | Chute, Discharge |
| 10 | 103-6402 | 2 | Blade-Notched | 28:2 | 116-4229-01 | 1 | Bracket-Chute, Discharge |
| 11 | 103-3037 | 2 | Bushing, Splined | 28:3 | 3231-22 | 3 | Bolt-Carriage 3/8-16 X 1 |
| 12 | 109-9220 | 2 | Screw-Sems 1/2-20 X 2.19 | 28:4 | 109-6658 | 3 | Nut-Nyloc 3/8-16 Flg |
| 13 | 116-1286 | 2 | Guard,Bearing Top .989 | 29 | 3231-28 | 6 | Bolt-Carriage 3/8-16 X 1 1/4 |
| 14 | 109-6658 | 21 | Nut-Nyloc 3/8-16 Flg | 30 | 103-2802 | 2 | Washer-Spring Disc 3/4 |
| 15 | 116-0675 | 2 | Sheave,Blade Drive 6.50 ■ | | | | |

● Requires installation of mulch kit for proper mulching. See your Exmark dealer for details.

■ Apply Mobil HTS grease (P/N 103-5217 1.5 oz packet) (or a food-grade anti-seize). See operator s manual for locations.

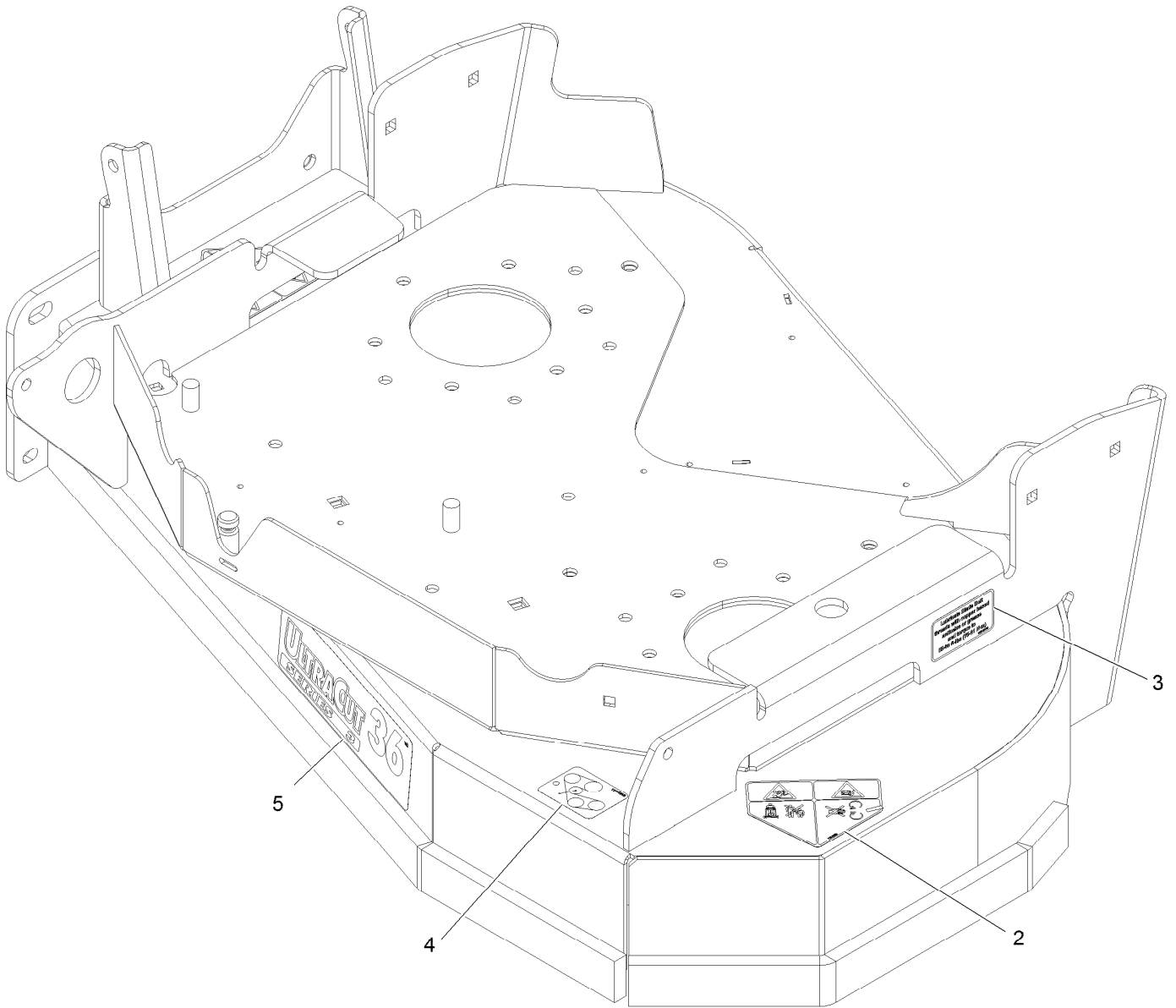

Deck W/Decals Assembly No. 116-3662

| <i>Ref.</i> | <i>Part Number</i> | <i>Qty.</i> | <i>Description</i> |
|-------------|--------------------|-------------|----------------------------|
| 2 | 112-8760 | 2 | Decal-Danger |
| 3 | 109-3148 | 1 | Decal, Bolt Torque |
| 4 | 116-4298 | 1 | Decal-Belt Routing 36 |
| 5 | 116-4695 | 1 | Decal-Ultracut 36 Series 3 |

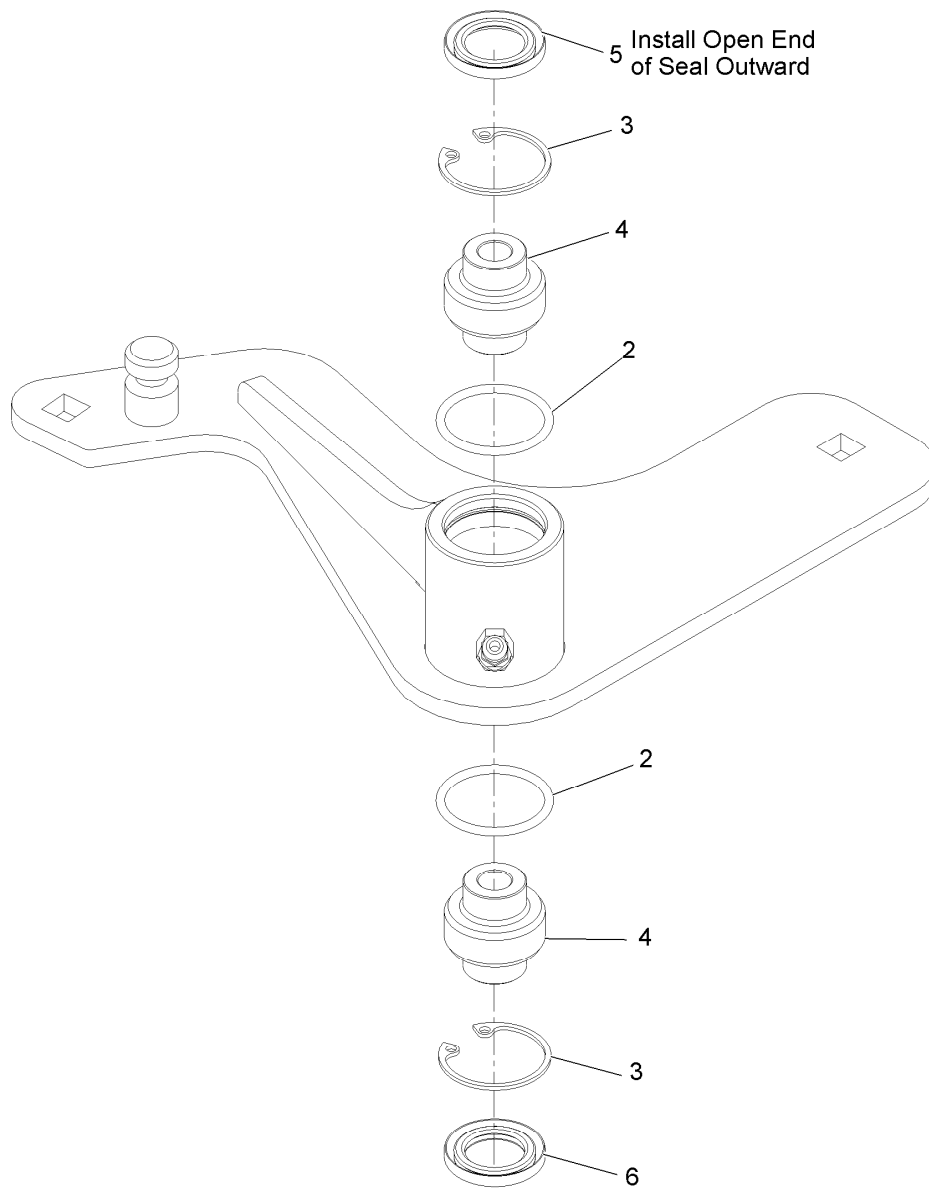

Idler Arm Assembly No. 116-3680

| <i>Ref.</i> | <i>Part Number</i> | <i>Qty.</i> | <i>Description</i> |
|-------------|--------------------|-------------|--------------------|
| 2 | 106-7159 | 2 | O-Ring |
| 3 | 32120-10 | 2 | Ring-Retaining |
| 4 | 103-3504 | 2 | Bearing-Spherical |
| 5 | 103-3506 | 1 | Seal-Single Lip |
| 6 | 103-3505 | 1 | Seal-Double Lip |

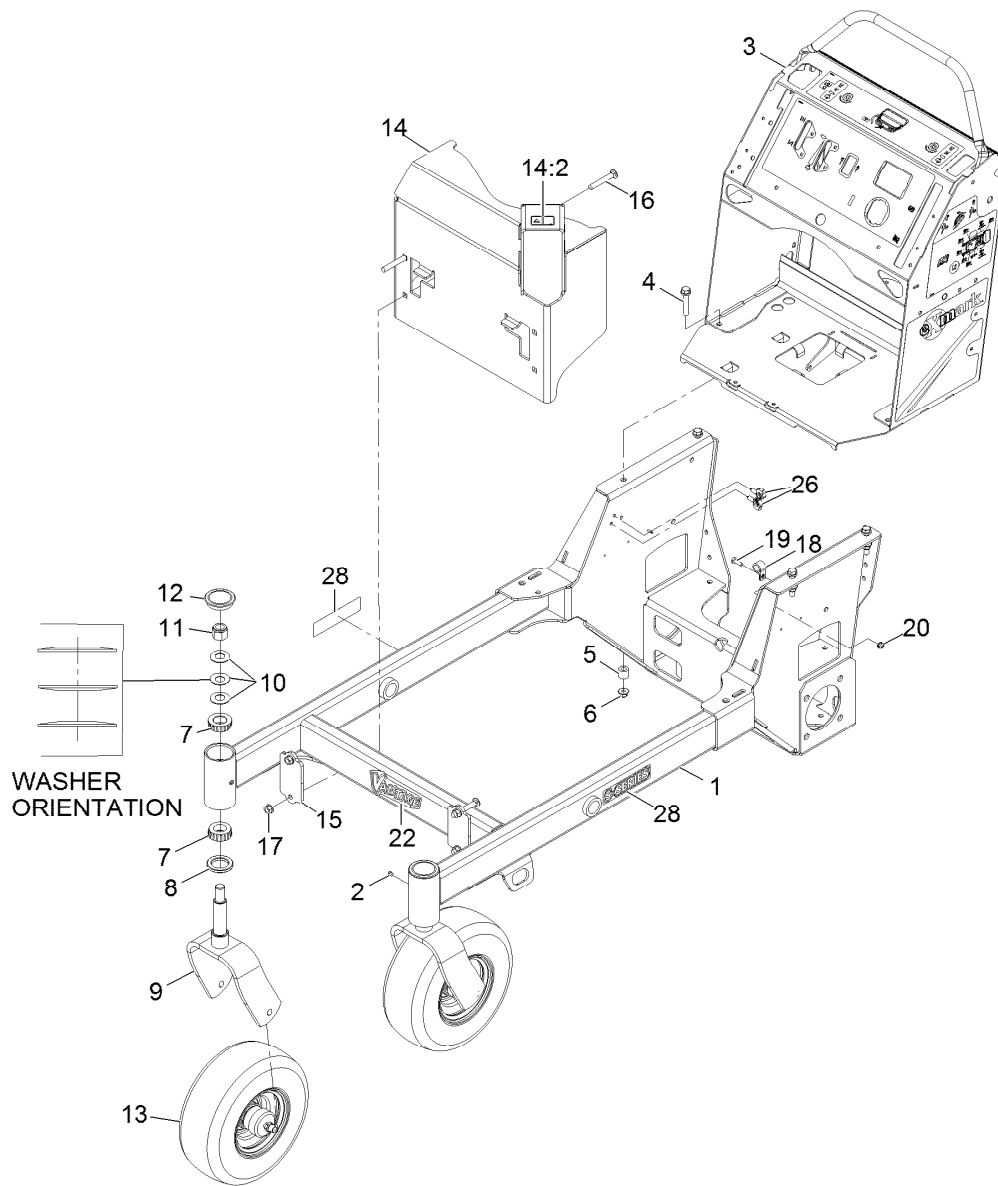

Main Frame Assembly

| Ref. | Part Number | Qty. | Description | Ref. | Part Number | Qty. | Description |
|------|-------------|------|-----------------------------|------|-------------|------|------------------------------|
| 1 | 116-4650-01 | 1 | Frame ASM | 14 | 116-8739 | 1 | Muffer Guard ASM |
| 2 | 1-811010 | 2 | Plug | 14:2 | 106-5517 | 1 | Decal-Warning, Hot Surface |
| 3 | 116-6323 | 1 | Control Tower ASM | 15 | 119-7303-01 | 2 | Bracket-Mounting, Guard |
| 4 | 108-3742 | 4 | Screw-HH Flg 3/8-16 X 2 | 16 | 3231-31 | 4 | Bolt-Carriage 3/8-16 X 2 1/2 |
| 5 | 121-1760 | 4 | Spacer | 17 | 32128-21 | 4 | Nut-3/8-16 Flanged Side Lock |
| 6 | 104-8301 | 4 | Nut-Nyloc 3/8-16 Flg | 18 | 2412-87 | 1 | Clamp-Cable |
| 7 | 1-543509 | 4 | Cone-Bearing Tapered Roller | 19 | 321-4 | 1 | Screw-HH 1/4-20 X 3/4 |
| 8 | 116-5647 | 2 | Seal-Grease | 20 | 104-7201 | 1 | Nut-Nyloc 1/4-20 Flg |
| 9 | 121-7988-01 | 2 | Caster Fork ASM | 22 | 116-4268 | 1 | Decal-Vantage Logo |
| 10 | 1-633508 | 6 | Washer-Spring Disc | 26 | 32180-040 | 2 | Clip-Harness |
| 11 | 3296-51 | 2 | Nut-Nyloc 3/4-10 | 28 | 116-3884 | 2 | Decal-S-Series |
| 12 | 103-4882 | 2 | Cap-Grease | | | | |
| 13 | 112-3810 | 2 | Wheel/Tire And Bearing ASM | | | | |

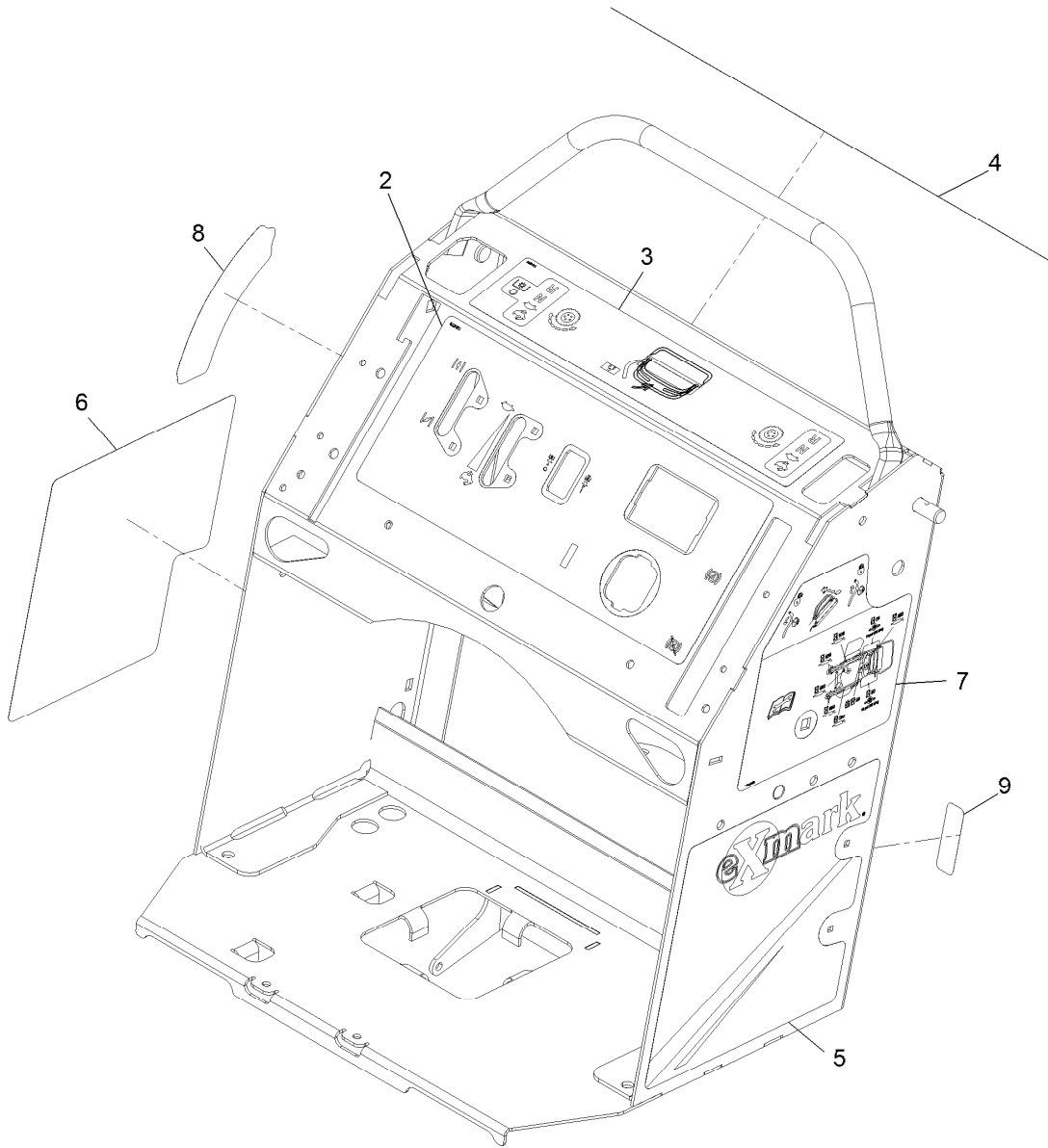

Control Tower W/Decals Assembly No. 116-6323

| <i>Ref.</i> | <i>Part Number</i> | <i>Qty.</i> | <i>Description</i> |
|-------------|--------------------|-------------|----------------------|
| 2 | 116-8779 | 1 | Decal-Control Panel |
| 3 | 116-8781 | 1 | Decal-Motion Control |
| 4 | 116-8780 | 1 | Decal-Warning |
| 5 | 116-4269 | 1 | Decal-LH Panel |
| 6 | 116-1909 | 1 | Decal-RH Panel |
| 7 | 116-8819 | 1 | Decal-Service Aid |
| 8 | 116-4270 | 1 | Decal-Height Of Cut |
| 9 | 116-8772 | 1 | Decal-Fuse |

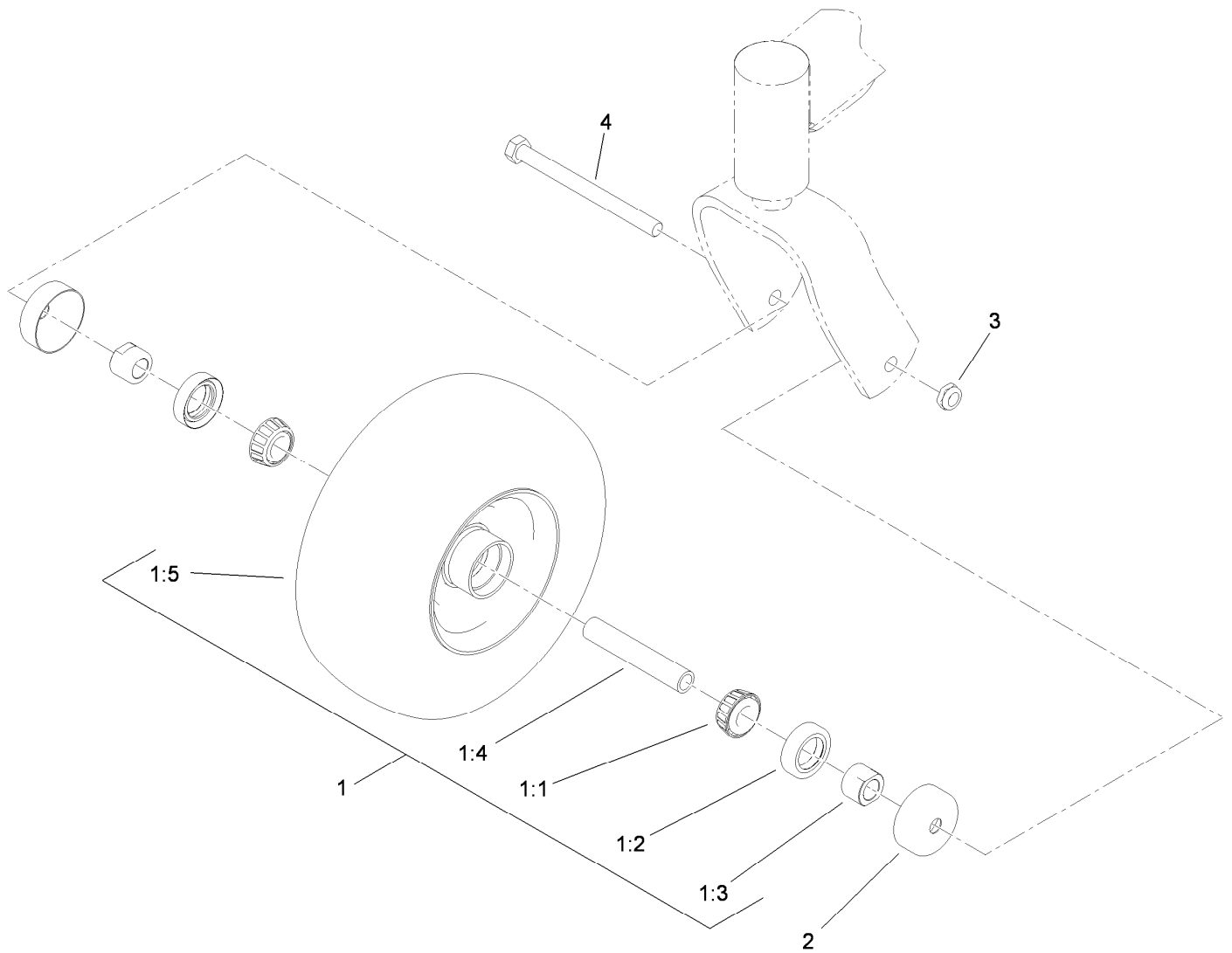

Wheel and Bearing Assembly No. 112-3810

| Ref. | Part Number | Qty. | Description |
|------|-------------|------|-------------------------|
| 1 | | 1 | Wheel And Bearing ASM ● |
| 1:1 | 1-633585 | 2 | Bearing-Cone, Taper |
| 1:2 | 103-0063 | 2 | Seal-Caster |
| 1:3 | 103-3051 | 2 | Spacer-Nut ■ |
| 1:4 | 103-3157 | 1 | Axle-Caster |
| 1:5 | 110-9965 | 1 | Wheel And Tire ASM |
| 2 | 103-2768 | 2 | Guard-Seal |
| 3 | 3296-45 | 1 | Nut-Lock, NI |
| 4 | 325-20 | 1 | Screw-HH |

● Not serviced separately

■ Use Pro-Lock, Nut Type (P/N 1-840022, .5ml tube) on spacer nut

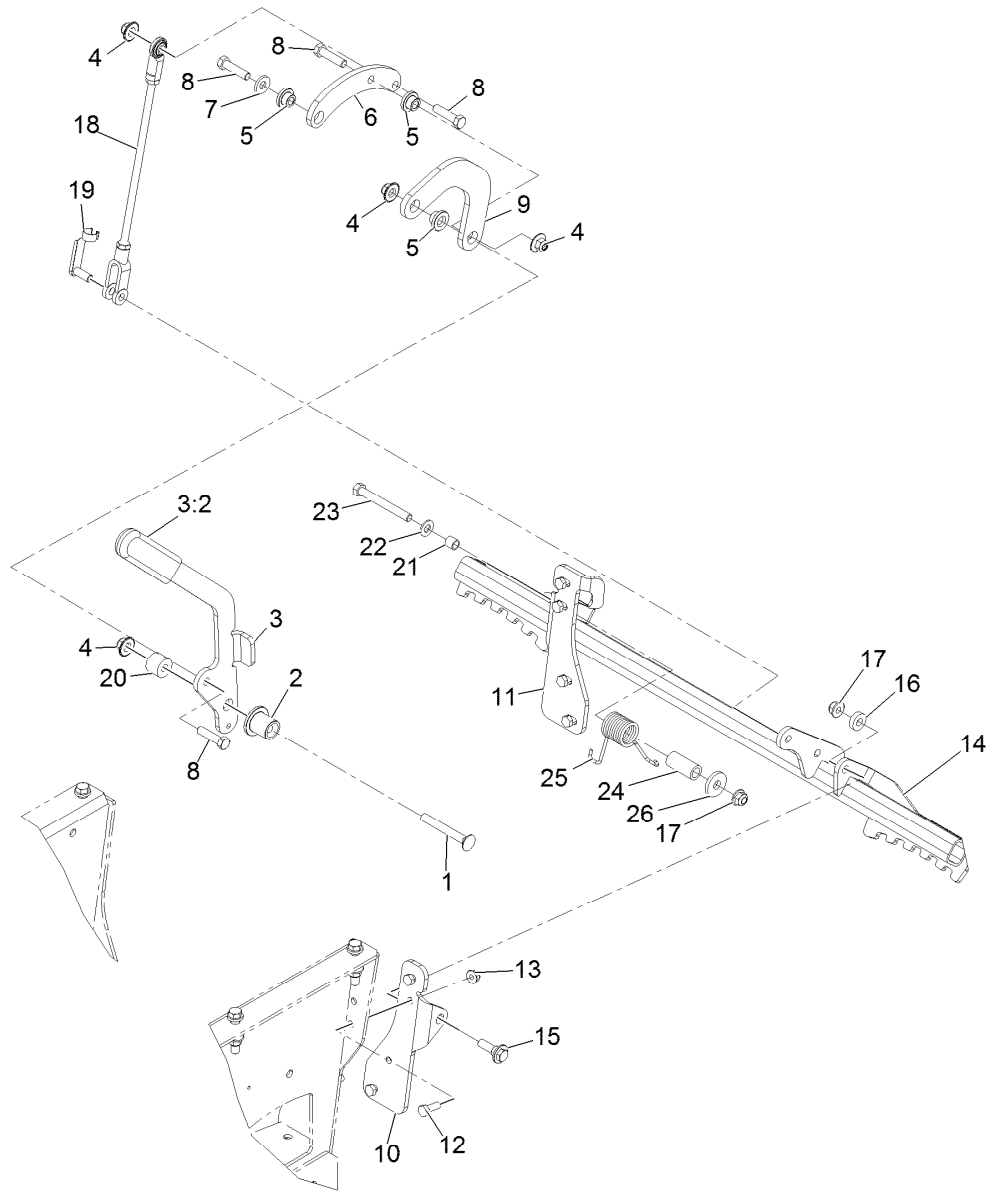

Park Brake Assembly

| Ref. | Part Number | Qty. | Description | Ref. | Part Number | Qty. | Description |
|------|-------------|------|--------------------------|------|-------------|------|-------------------------------|
| 1 | 3231-10 | 1 | Bolt-Carriage 3/8-16 X 3 | 14 | 116-4600-03 | 1 | Bar-Brake |
| 2 | 116-4928 | 1 | Bushing-Handle | 15 | 614672 | 1 | Screw-Shoulder 3/8-16 X 1.295 |
| 3 | 116-4680 | 1 | Handle-W/Grip ASM | 16 | 5-0652 | 1 | Spacer |
| 3:2 | 1-633268 | 1 | Grip-Lever | 17 | 104-8301 | 2 | Nut-Nyloc 3/8-16 Flg |
| 4 | 109-6658 | 4 | Nut-Nyloc 3/8-16 Flg | 18 | 116-4166 | 1 | ASM-Brake Linkage |
| 5 | 116-4929 | 3 | Bushing-Flanged | 19 | 103-2399 | 1 | Pin-Clevis Spring 3/8 |
| 6 | 116-4806 | 1 | Arm-Brake Bellcrank | 20 | 92-5791 | 1 | Spacer |
| 7 | 98-5975 | 1 | Washer-Spring Disc 3/8 | 21 | 117-9684 | 1 | Spacer |
| 8 | 323-8 | 4 | Screw-HH 3/8-16 X 1 1/2 | 22 | 3256-24 | 1 | Washer-3/8 Sae |
| 9 | 116-4805 | 1 | Link-Brake Handle | 23 | 323-20 | 1 | Screw-HH 3/8-16 X 3-1/4 |
| 10 | 116-4681-01 | 1 | Bracket-Brake Mount, LH | 24 | 117-9683 | 1 | Spacer |
| 11 | 116-4682-01 | 1 | Bracket-Brake Mount, RH | 25 | 108-4052 | 1 | Spring-Torsion |
| 12 | 322-4 | 8 | Screw-HH 5/16-18 X 7/8 | 26 | 1-373034 | 1 | Washer |
| 13 | 104-8300 | 8 | Nut-Nyloc 5/16-18 Flg | | | | |

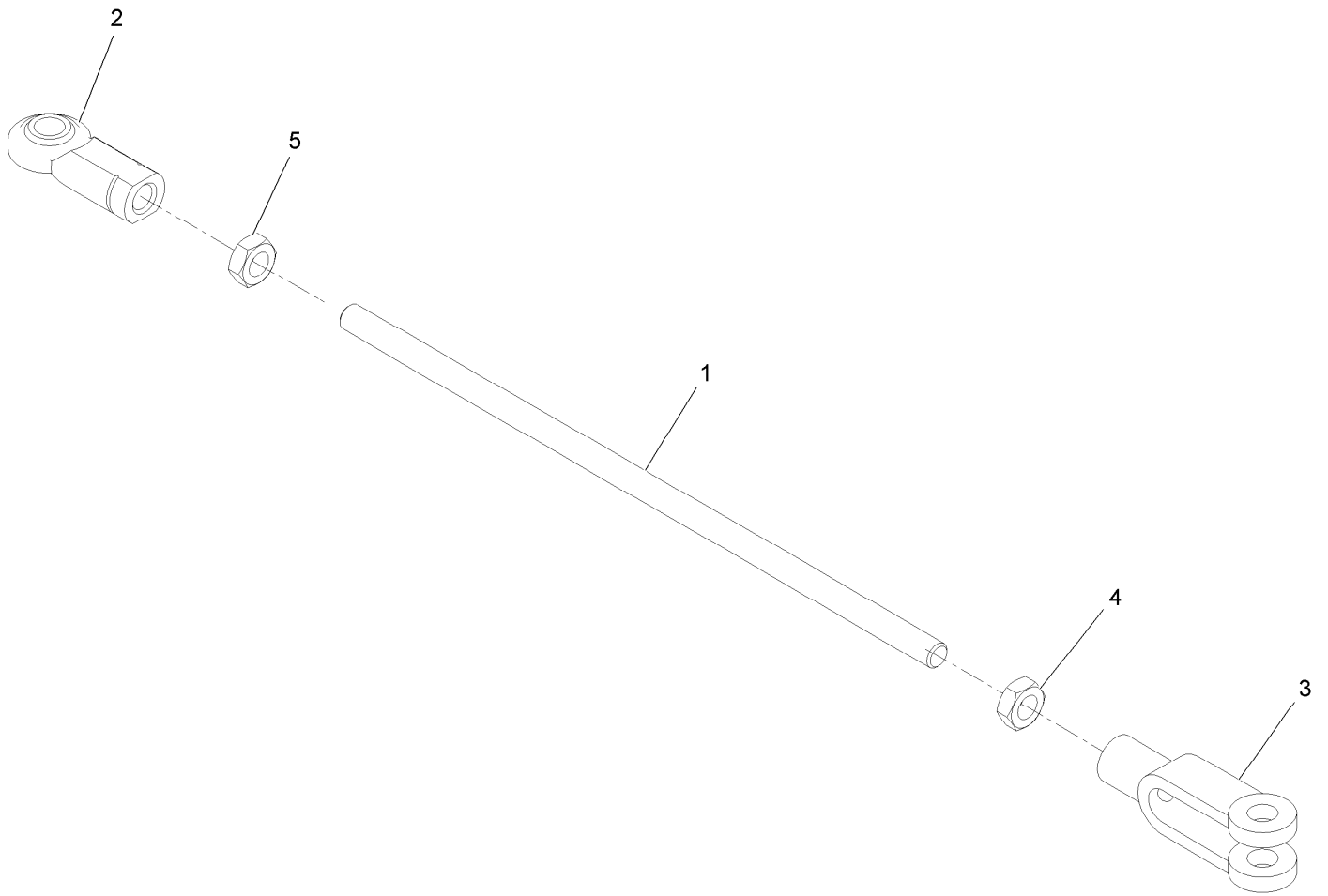

Brake Linkage Assembly No. 116-4166

| <i>Ref.</i> | <i>Part Number</i> | <i>Qty.</i> | <i>Description</i> |
|-------------|--------------------|-------------|------------------------------|
| 1 | 116-4818 | 1 | Rod-Brake Linkage |
| 2 | 103-1167 | 1 | Joint-Ball End, .38X.38Fe LH |
| 3 | 1-633131 | 1 | Yoke-Linkage, Brake |
| 4 | 3220-3 | 1 | Nut-Jam 3/8-24 |
| 5 | 3220-16 | 1 | Nut-Jam 3/8-24 LH |

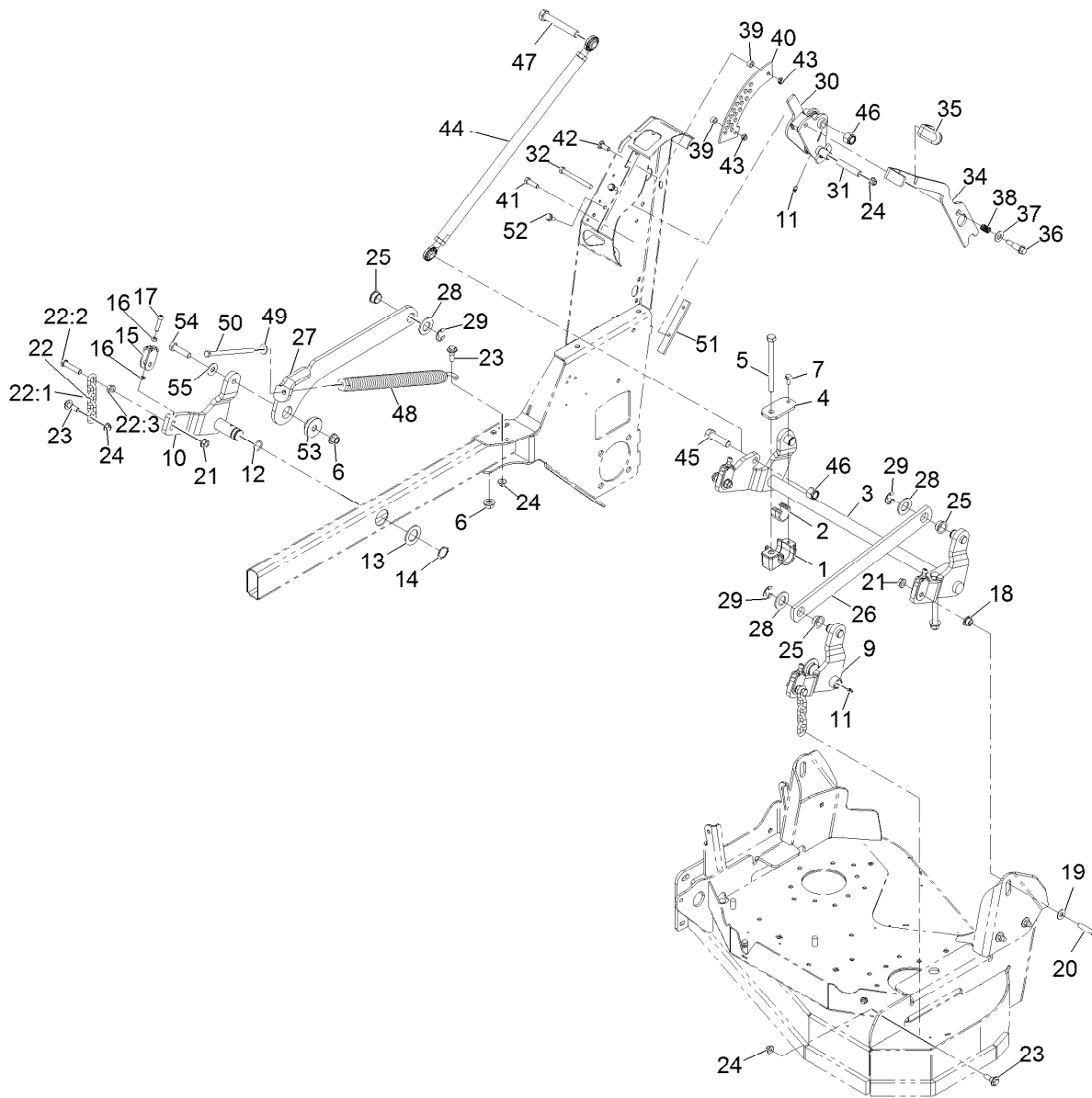

Deck Lift Assembly

| Ref. | Part Number | Qty. | Description | Ref. | Part Number | Qty. | Description |
|------|-------------|------|------------------------------|------|-------------|------|-------------------------------|
| 1 | 116-4638-01 | 2 | Support-Bearing | 22 | 116-0756 | 2 | Deck Lift Chain ASM |
| 2 | 109-9410 | 2 | Bearing-Cross Shaft, Front | 22:1 | 1-633447 | 1 | Chain-Lift, Deck |
| 3 | 116-3725-01 | 1 | Rear Crossshaft ASM | 22:2 | 109-9065 | 1 | Screw-HH 7/16-14 X 2 |
| 4 | 116-3733-01 | 2 | Cover-Bearing Support | 22:3 | 32128-37 | 1 | Nut-Whizlock 7/16-14 |
| 5 | 325-20 | 2 | Screw-HH 1/2-13 X 6 | 23 | 109-9840 | 3 | Screw-Hex Flange 3/8-16 X .80 |
| 6 | 99-5107 | 3 | Nut-Lock 1/2-13 | 24 | 104-8301 | 4 | Nut-Nyloc 3/8-16 Flg |
| 7 | 100-1668 | 2 | Screw-Flange | 25 | 116-2909 | 3 | Bearing-Flange |
| 9 | 116-4663-01 | 1 | Decklift Arm ASM-LH | 26 | 116-3972-03 | 1 | Link-Decklift, LH |
| 10 | 116-4664-01 | 1 | Decklift Arm ASM-RH | 27 | 116-4661-03 | 1 | Link-Decklift, RH |
| 11 | 302-5 | 3 | Zerk 1/4-28 Str Thrd Forming | 28 | 3256-29 | 3 | Washer-7/8 Sae |
| 12 | 237-77 | 2 | O Ring | 29 | 32151-103 | 3 | E-Ring |
| 13 | 69-8910 | 2 | Washer | 30 | 116-5602 | 1 | ASM-HOC Handle |
| 14 | 32120-2 | 2 | Ring-Retaining | 31 | 116-4021 | 1 | Bearing-HOC Pivot |
| 15 | 109-9066 | 4 | Yoke-Adjust, Deck | 32 | 323-42 | 1 | Screw-HH 3/8-16 X 3 3/4 |
| 16 | 3218-2 | 8 | Nut-Jam 5/16-18 | 34 | 114-1878-03 | 1 | Lever-HOC |
| 17 | 3274-18 | 4 | Screw-Sh 5/16-18 X 1 1/4 | 35 | 1-633268 | 1 | Grip-Lever |
| 18 | 116-2428 | 2 | Bushing-Flanged | 36 | 66-0561 | 1 | Screw-Shoulder |
| 19 | 3256-4 | 2 | Washer-3/8 Std | 37 | 3256-26 | 1 | Washer-1/2 Sae |
| 20 | 109-9065 | 2 | Screw-HH 7/16-14 X 2 | 38 | 65-9940 | 1 | Spring |
| 21 | 32128-37 | 4 | Nut-Whizlock 7/16-14 | 39 | 111044 | 2 | Bushing |

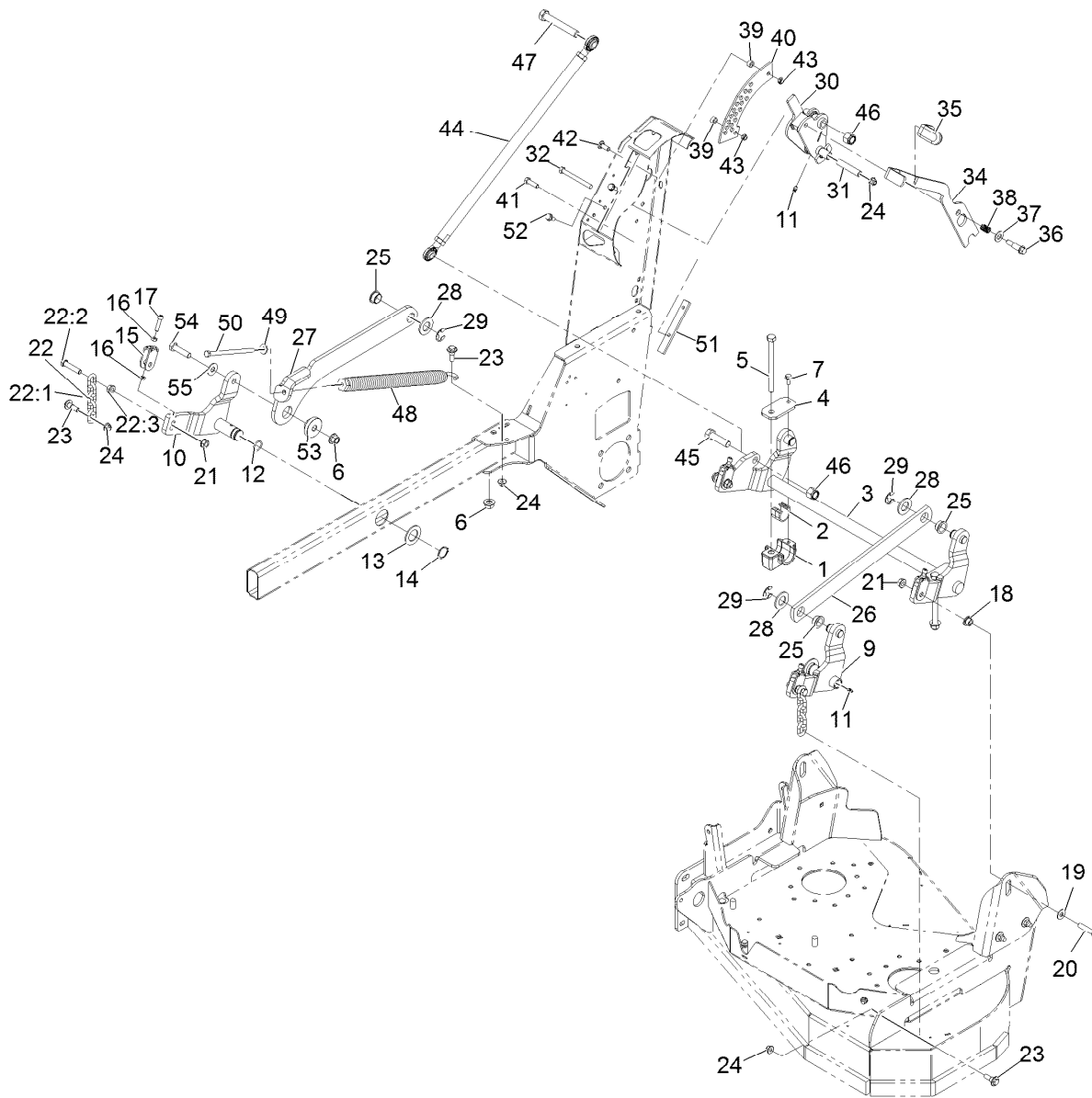

Deck Lift Assembly (continued)

| Ref. | Part Number | Qty. | Description | Ref. | Part Number | Qty. | Description |
|------|-------------|------|--------------------------|------|-------------|------|----------------------------|
| 40 | 116-3971 | 1 | Bracket-HOC | 49 | 98-5975 | 1 | Washer-Spring Disc 3/8 |
| 41 | 323-7 | 1 | Screw-HH 3/8-16 X 1 1/4 | 50 | 323-58 | 1 | Bolt-HH 3/8-16 X 6 Tap |
| 42 | 3231-22 | 1 | Bolt-Carriage 3/8-16 X 1 | 51 | 116-3124 | 1 | Skid-Handle, Lift |
| 43 | 3296-59 | 2 | Nut-Nyloc 3/8-16 Thin | 52 | 32144-11 | 2 | Screw-HWH 5/16-18 X 3/4 Tf |
| 44 | 116-3975 | 1 | HOC Link ASM | 53 | 116-4702 | 1 | Bushing-Flanged |
| 45 | 327-22 | 1 | Screw-HH | 54 | 325-8 | 1 | Screw-HH 1/2-13 X 1 1/4 |
| 46 | 3296-53 | 2 | Nut-Nyloc 5/8-11 | 55 | 3256-5 | 1 | Washer-7/16 Std |
| 47 | 327-29 | 1 | Screw-HH | | | | |
| 48 | 116-0886 | 1 | Extension Spring ASM | | | | |

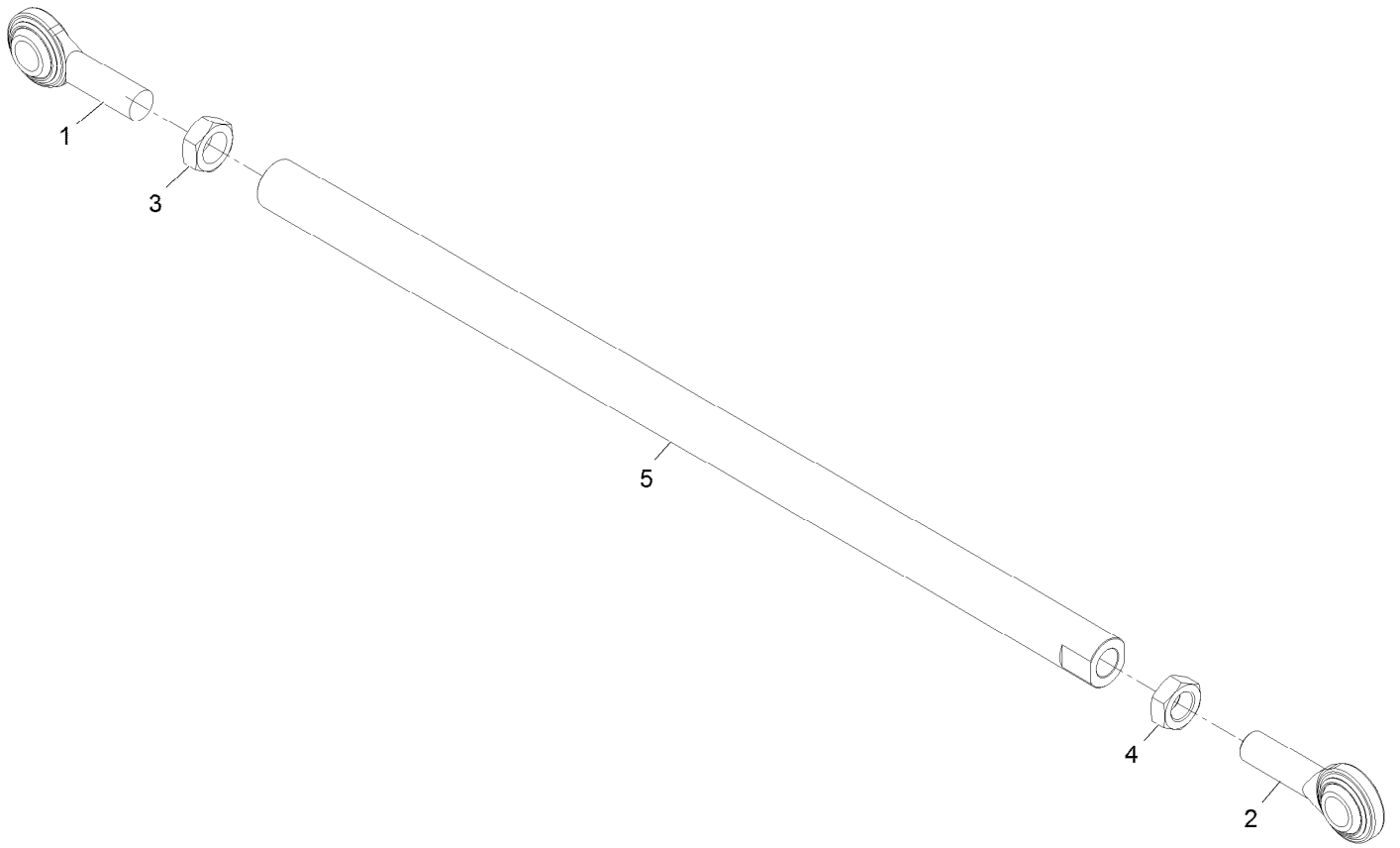

Height of Cut Link Assembly No. 116-3975

| <i>Ref.</i> | <i>Part Number</i> | <i>Qty.</i> | <i>Description</i> |
|-------------|--------------------|-------------|---------------------|
| 1 | 1-633029 | 1 | Balljoint |
| 2 | 117-5291 | 1 | Balljoint-Spherical |
| 3 | 3220-6 | 1 | Nut-Jam |
| 4 | 117-5293 | 1 | Nut-Jam |
| 5 | 116-5488 | 1 | Link-Height Of Cut |

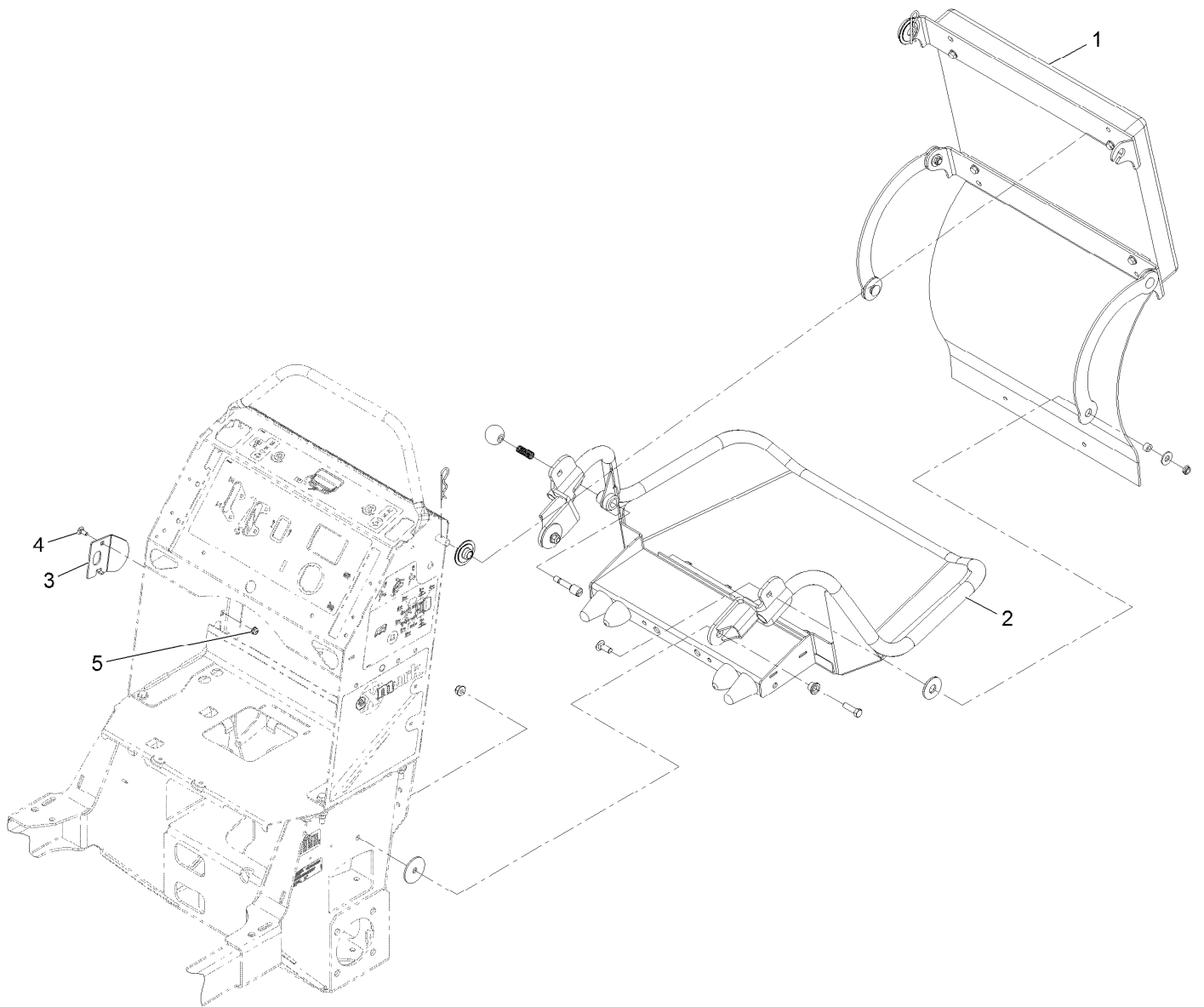

Platform Assembly

| <i>Ref.</i> | <i>Part Number</i> | <i>Qty.</i> | <i>Description</i> |
|-------------|--------------------|-------------|----------------------------|
| 1 | 126-1210 | 1 | ASM, Cushion |
| 2 | 116-3523 | 1 | Platform ASM |
| 3 | 119-7312 | 1 | Plate-Striker |
| 4 | 3229-11 | 1 | Bolt-Carriage 1/4-20 X 5/8 |
| 5 | 104-7201 | 1 | Nut-Nyloc 1/4-20 Flg |

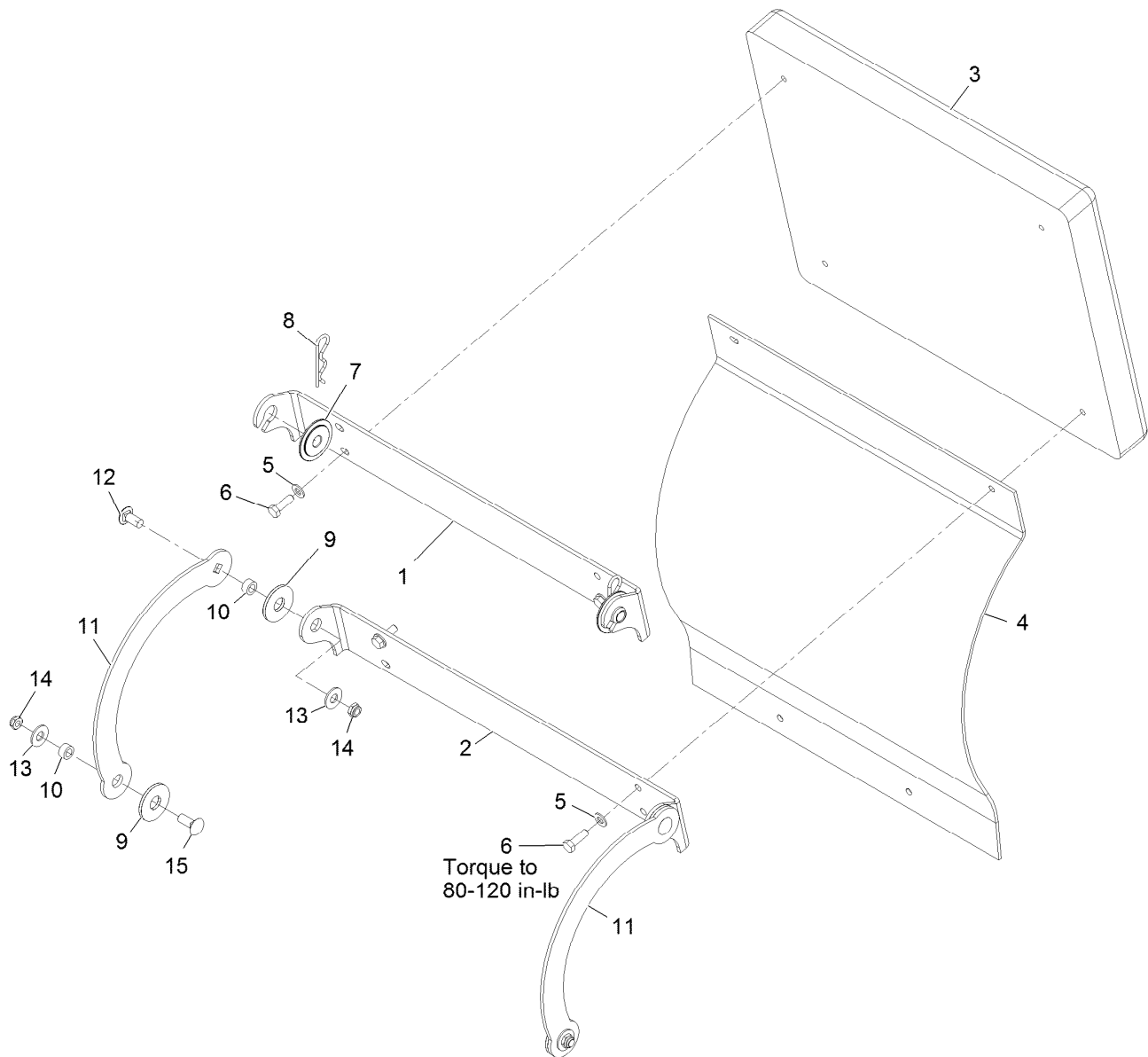

Cushion Assembly No. 126-1210

| Ref. | Part Number | Qty. | Description |
|------|-------------|------|------------------------------|
| 1 | 116-2757-03 | 1 | Hinge-Pad |
| 2 | 116-2061-03 | 1 | Hinge-Pad |
| 3 | 116-1790 | 1 | Pad,Grey Cushion |
| 4 | 126-0362 | 1 | Shield, Rear |
| 5 | 3256-23 | 4 | Washer-5/16 Sae |
| 6 | 116-0648 | 4 | Screw-HH 5/16-18 X 1 W/Patch |
| 7 | 116-2886 | 2 | Slide-Bushing |
| 8 | 3290-355 | 2 | Pin-Hair |
| 9 | 114-0463 | 4 | Washer-Friction, Composite |
| 10 | 111044 | 4 | Bushing |
| 11 | 114-1915-03 | 2 | Link-Pad |
| 12 | 3231-27 | 2 | Bolt-Carriage 3/8-16 X 7/8 |
| 13 | 3256-4 | 4 | Washer-3/8 Std |
| 14 | 3296-59 | 4 | Nut-Nyloc 3/8-16 Thin |
| 15 | 3231-2 | 2 | Bolt-Carriage 3/8-16 X 1 |

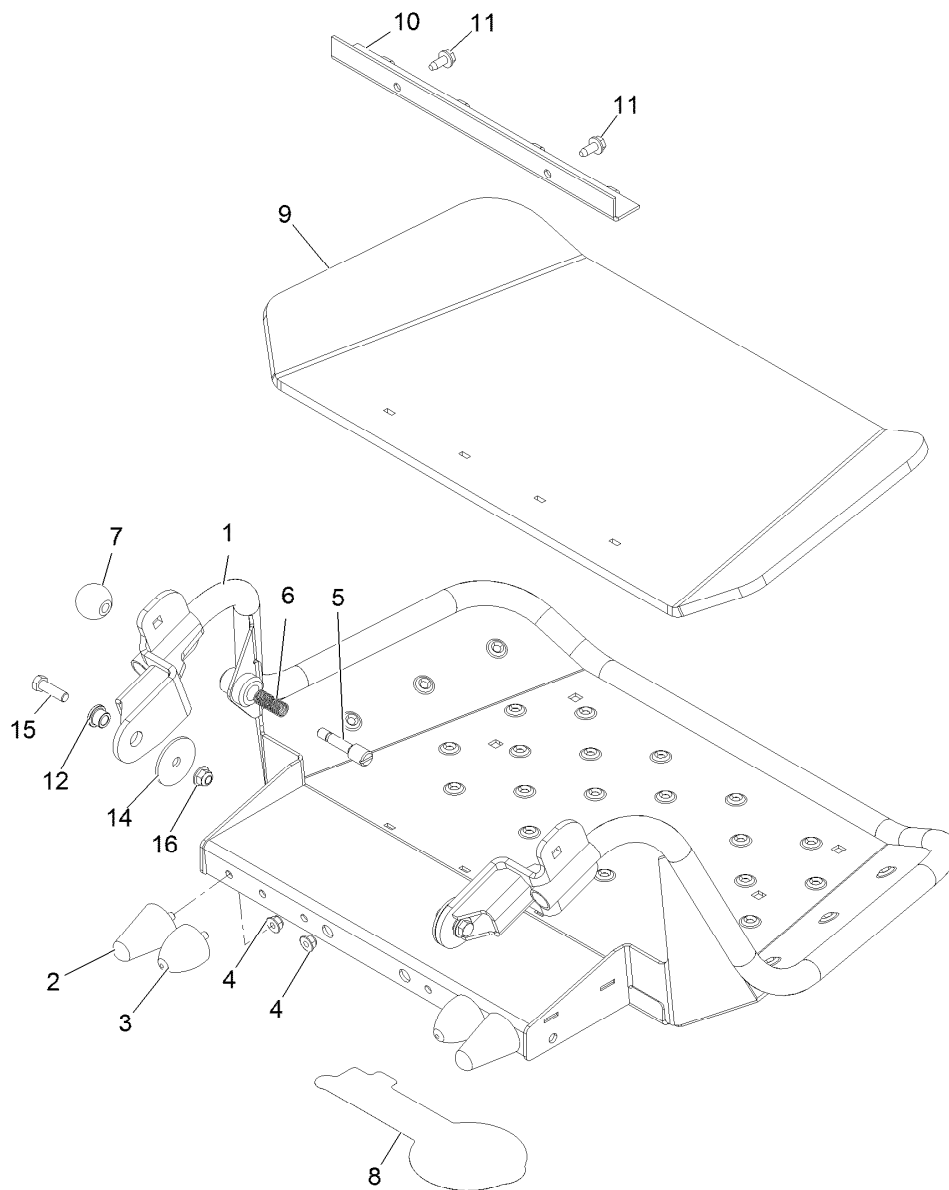

Platform Assembly No. 116-3523

| Ref. | Part Number | Qty. | Description |
|------|-------------|------|----------------------------|
| 1 | 117-7660-03 | 1 | Platform ASM |
| 2 | 114-1925 | 2 | Bumper-Rubber |
| 3 | 114-1926 | 2 | Bumper-Rubber |
| 4 | 104-8300 | 4 | Nut-Nyloc 5/16-18 Flg |
| 5 | 119-8650 | 1 | Pin-Latch ● |
| 6 | 114-5348 | 1 | Spring |
| 7 | 1-603175 | 1 | Knob-Ball |
| 8 | 1-653546 | 1 | Decal, Exmark |
| 9 | 114-5349 | 1 | Mat-Foot |
| 10 | 114-1920-03 | 1 | Clamp-Shield |
| 11 | 32144-70 | 2 | Screw-HWH 5/16-18 X 3/4 Tf |
| 12 | 109-8788 | 2 | Bushing-Flanged |
| 14 | 83-1040 | 2 | Washer |
| 15 | 323-7 | 2 | Screw-HH 3/8-16 X 1 1/4 |
| 16 | 104-8301 | 2 | Nut-Nyloc 3/8-16 Flg |

● Use Pro-Lock, Nut Type (P/N 1-840022, .5ml tube) on threads.

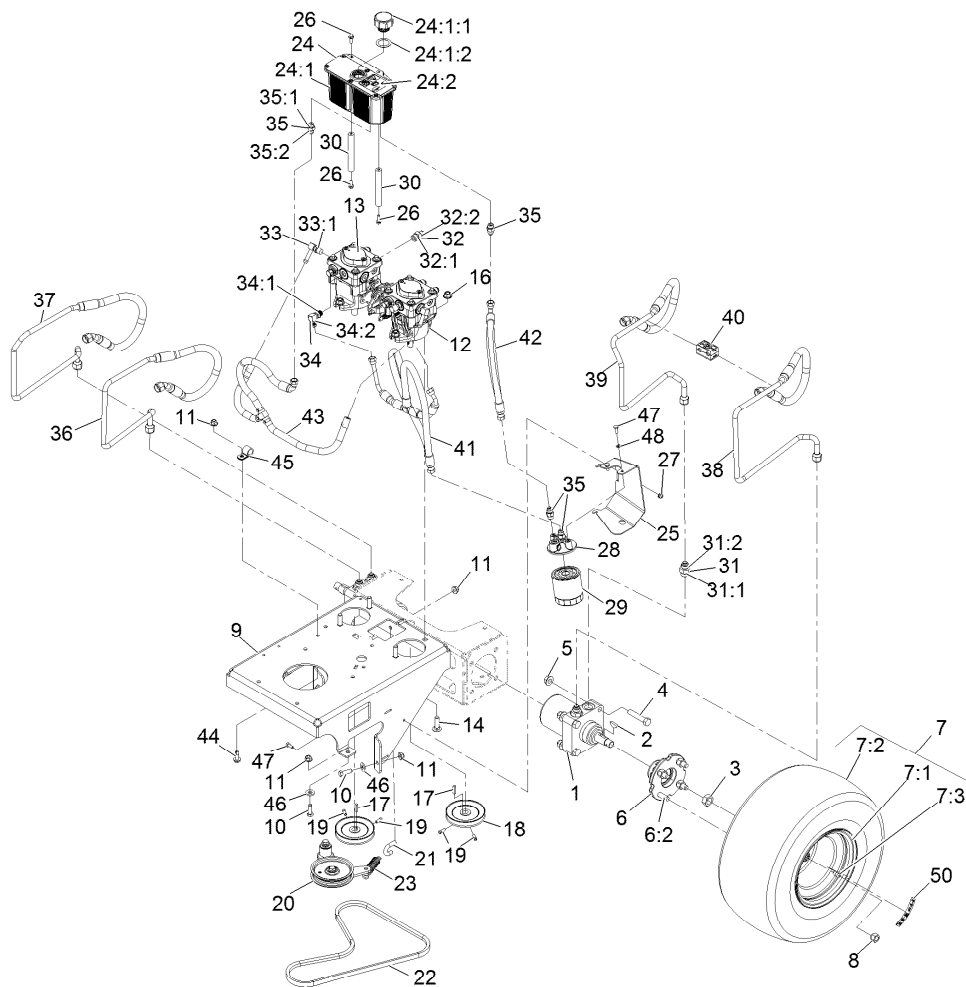

Ground Drive Assembly

| Ref. | Part Number | Qty. | Description | Ref. | Part Number | Qty. | Description |
|------|-------------|------|--------------------|--------|-------------|------|--------------------------|
| 1 | 104-1171 | 2 | HYD Motor ASM | 22 | 119-0174 | 1 | Belt-V |
| 2 | 3257-8 | 2 | Key-Woodruff | 23 | 108-4056 | 1 | Spring-Extension |
| 3 | 85-7310 | 2 | Nut-Motor, Wheel | 24 | 116-2066 | 1 | ASM,Reservoir W/Decals ▲ |
| 4 | 325-10 | 8 | Screw-HH | 24:1 | | 1 | Reservoir-HYD ● |
| 5 | 32128-23 | 8 | Nut-HF | 24:1:1 | 103-1948 | 1 | Cap-Reservoir, HYD |
| 6 | 105-0800 | 2 | Wheel Hub ASM | 24:1:2 | 103-1949 | 1 | Gasket-Cap |
| 6:2 | 10-6830 | 4 | Stud-Type, Drive | 24:2 | 115-4212 | 1 | Decal-Warning |
| 7 | 116-4587 | 2 | Wheel/Tire ASM | 25 | 116-4319-01 | 1 | Plate-Filter Mount |
| 7:1 | 116-4605 | 1 | Rim-8 Inch | 26 | 117-8304 | 4 | Screw-HHF |
| 7:2 | 116-4606 | 1 | Tire | 27 | 104-7201 | 1 | Nut-HF |
| 7:3 | 232-27 | 1 | Stem-Valve | 28 | 103-2888 | 1 | Head-Filter |
| 8 | 242-50 | 8 | Nut-Lug | 29 | 109-4180 | 1 | Element, Oil Filter |
| 9 | 116-8745-01 | 1 | Base, Engine [red] | 30 | 116-4343 | 2 | Rod-Reservoir Stand |
| 10 | 323-18 | 4 | Screw-HH | 31 | 1-603991 | 4 | Fitting-Straight |
| 11 | 104-8301 | 6 | Nut-Flange, NI | 31:1 | 237-80 | 1 | O-Ring |
| 12 | 116-2572 | 1 | Pump - Hydraulic | 31:2 | 1-603992 | 1 | O-Ring |
| 13 | 116-4635 | 1 | Pump-Hydraulic | 32 | 1-603990 | 4 | Fitting-Straight |
| 14 | 3232-3 | 4 | Bolt-CARR | 32:1 | 1-603920 | 1 | O-Ring |
| 16 | 114-8417 | 4 | Nut-HF, NI | 32:2 | 1-603992 | 1 | O-Ring |
| 17 | 1-807272 | 2 | Key | 33 | 100-4887 | 2 | Fitting-Barbed, 90 DEG |
| 18 | 105-5648 | 2 | Pulley-Pump ■ | 33:1 | 237-42 | 1 | O-Ring |
| 19 | 3241-5 | 4 | Screw-Set ◆ | 34 | 103-2155 | 2 | Fitting-90 DEG |
| 20 | 116-9980 | 1 | Pump Idler ASM | 34:1 | 1-603921 | 1 | O-Ring |
| 21 | 116-8526 | 1 | Anchor, Spring | 34:2 | 103-1020 | 1 | O-Ring |

● Not serviced separately

▲ Use Exmark Premium Hydro Oil P/N 109-9828 (32oz)

◆ Use Pro-Lock, Nut Type (P/N 1-840022, .5ml tube) on threads.

■ Apply anti-seize compound in bore.

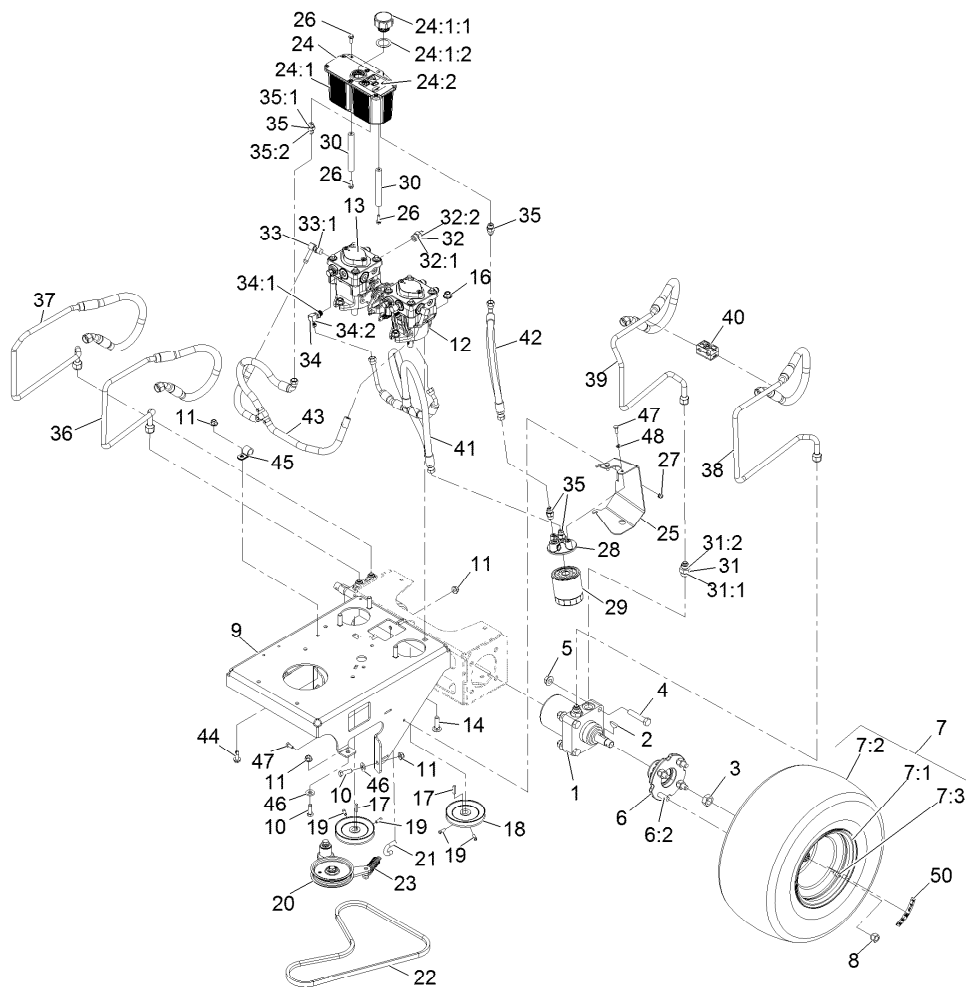

Ground Drive Assembly (continued)

| Ref. | Part Number | Qty. | Description | Ref. | Part Number | Qty. | Description |
|------|-------------|------|--------------------------------------|------|-------------|------|--------------------------|
| 35 | 103-2156 | 4 | Fitting-Straight | 42 | 116-4252 | 1 | Hose ASM-HYD LP 3/8X14.4 |
| 35:1 | 1-603921 | 1 | O-Ring | 43 | 116-5460 | 1 | Hose ASM - HYD 3/8 |
| 35:2 | 103-1020 | 1 | O-Ring | 44 | 105-6245 | 1 | Screw-Tapping |
| 36 | 116-5526 | 1 | Hose-Hardline | 45 | 1-633396 | 1 | Clip-Loom |
| 37 | 116-5525 | 1 | Hose-Hardline | 46 | 98-5975 | 4 | Washer-Belleville |
| 38 | 116-5523 | 1 | Hose-Hardline | 47 | 321-3 | 3 | Screw-HH |
| 39 | 116-5524 | 1 | Hose-Hardline | 48 | 1-805004 | 2 | Washer-Lock |
| 40 | 116-5804 | 2 | Clamp, Stauff 212,7/12,7 W/Retainers | 50 | 126-2130 | 2 | Decal-Wheel Torque |
| 41 | 116-5145 | 1 | Hose-ASM Charge | | | | |

● Not serviced separately

▲ Use Exmark Premium Hydro Oil P/N 109-9828 (32oz)

◆ Use Pro-Lock, Nut Type (P/N 1-840022, .5ml tube) on threads.

■ Apply anti-seize compound in bore.

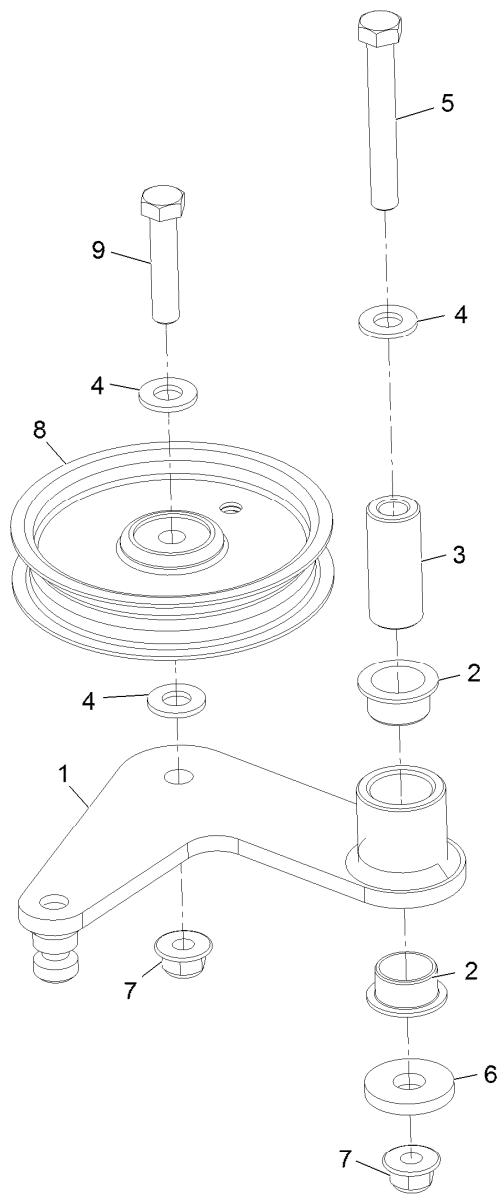

Pump Idler Assembly No. 116-9980

| <i>Ref.</i> | <i>Part Number</i> | <i>Qty.</i> | <i>Description</i> |
|-------------|--------------------|-------------|-------------------------|
| 1 | 116-8717 | 1 | Idler Arm ASM |
| 2 | 109-8054 | 2 | Bushing-Flanged |
| 3 | 116-8718 | 1 | Spacer, Pivot |
| 4 | 3256-24 | 3 | Washer-3/8 Sae |
| 5 | 323-13 | 1 | Screw-HH 3/8-16 X 2 3/4 |
| 6 | 1-373034 | 1 | Washer |
| 7 | 104-8301 | 2 | Nut-Nyloc 3/8-16 Flg |
| 8 | 93-1622 | 1 | Pulley-Idler |
| 9 | 323-9 | 1 | Screw-HH 3/8-16 X 1 3/4 |

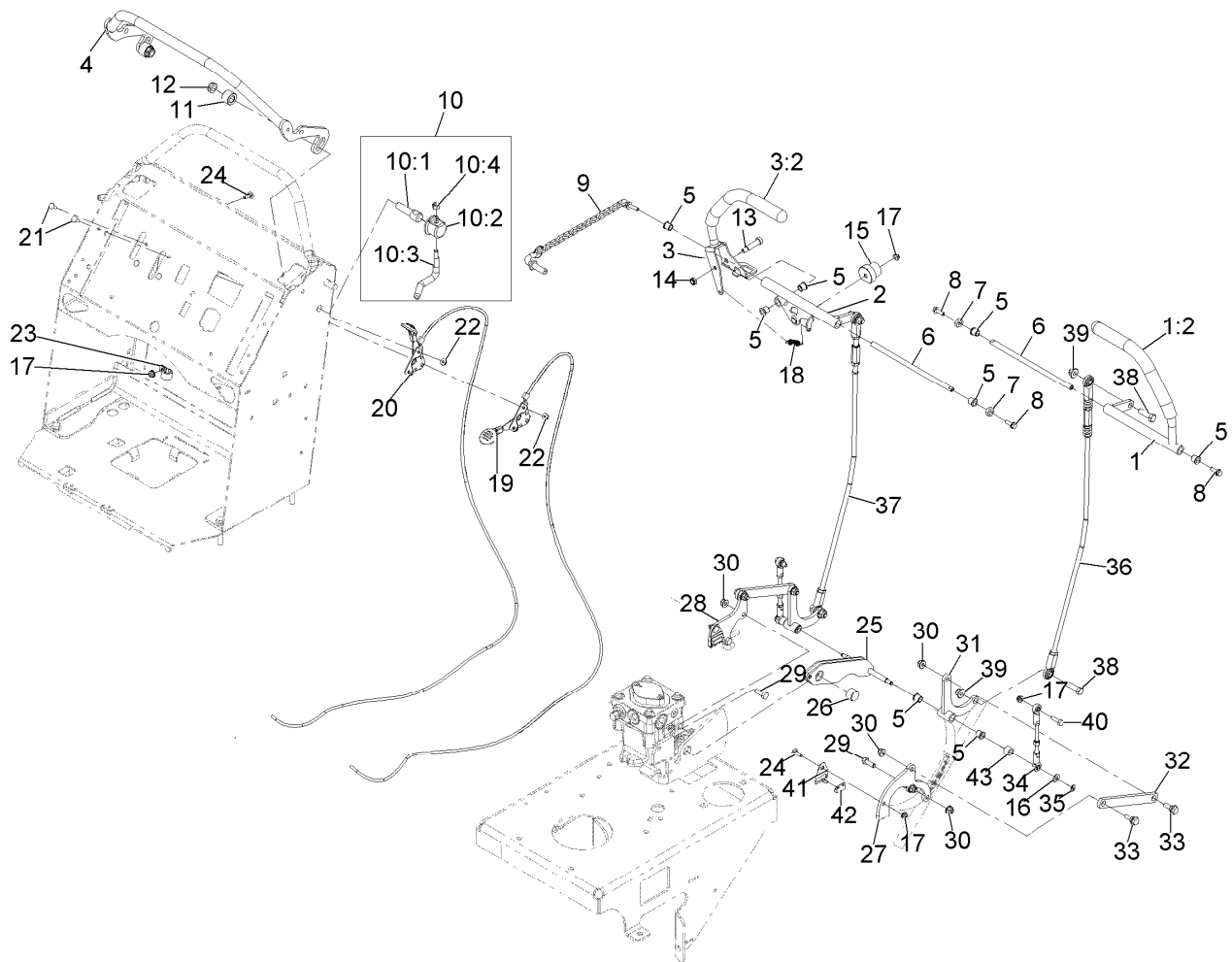

Control Assembly

| Ref. | Part Number | Qty. | Description | Ref. | Part Number | Qty. | Description |
|------|-------------|------|---------------------------------|------|-------------|------|----------------------------------|
| 1 | 116-4195 | 1 | Lever ASM, LH | 20 | 116-4277 | 1 | Control-Choke |
| 1:2 | 116-2357 | 1 | Grip-Handle, Control | 21 | 1-807533 | 4 | Bolt-Carriage #10-24 X 5/8 |
| 2 | 126-1943-03 | 1 | Weld, Motion Control | 22 | 3290-148 | 4 | Nut-Whizlock #10-24 |
| 3 | 116-9815 | 1 | ASM, Lever W/ Grip, Rt | 23 | 2412-87 | 1 | Clamp-Cable |
| 3:2 | 116-2357 | 1 | Grip-Handle, Control | 24 | 3229-1 | 3 | Bolt-Carriage 1/4-20 X 3/4 |
| 4 | 116-6985-03 | 1 | Tube ASM, Front Speed Control [| 25 | 116-4740 | 1 | Bellcrank Link ASM |
| 5 | 103-9928 | 10 | Bearing | 26 | 116-4203 | 1 | Pin-Bellcrank Link Retaining |
| 6 | 116-4197 | 2 | Shaft-Pivot, Motion Control | 27 | 116-4737 | 1 | Arm-Pump Control |
| 7 | 116-4198 | 2 | Spacer-Drive Lever Shaft | 28 | 116-7000 | 1 | Arm-Pump Control RH |
| 8 | 117-8304 | 3 | Screw-Hex Flange 1/4-20 X 3/4 | 29 | 322-4 | 4 | Screw-HH 5/16-18 X 7/8 |
| 9 | 114-0409 | 1 | HOC Pin ASM | 30 | 104-8300 | 8 | Nut-Nyloc 5/16-18 Flg |
| 10 | 107-1664 | 2 | Lever ASM | 31 | 116-4205 | 2 | Bellcrank-Lower |
| 10:1 | 106-3239 | 1 | Screw-Lock | 32 | 116-4208 | 2 | Link-Bellcrank, Pump |
| 10:2 | 107-1644 | 1 | Cap-Lock | 33 | 116-2670 | 4 | Screw-Shoulder HHF 5/16-18 X .96 |
| 10:3 | 106-3241 | 1 | Lever-Lock | 34 | 116-4210 | 2 | Vertical Adjust Link |
| 10:4 | 3296-29 | 1 | Nut-Nyloc 5/16-18 | 35 | 32151-86 | 2 | E-Ring |
| 11 | 116-2319 | 2 | Spacer-Clamp | 36 | 116-4213 | 1 | Linkage-Tracking Control, LH |
| 12 | 3296-45 | 2 | Nut-Nyloc 1/2-13 Thin | 37 | 116-4214 | 1 | Linkage-Tracking Control, RH |
| 13 | 114-0239 | 1 | Screw-Shoulder 5/16-18 X 1/2 | 38 | 323-7 | 4 | Screw-HH 3/8-16 X 1 1/4 |
| 14 | 3296-47 | 1 | Nut-Nyloc 5/16-18 Thin | 39 | 104-8301 | 4 | Nut-Nyloc 3/8-16 Flg |
| 15 | 126-1499 | 1 | Cam | 40 | 321-5 | 2 | Screw-HH 1/4-20 X 7/8 |
| 16 | 3256-22 | 2 | Washer-1/4 Sae | 41 | 116-4739 | 2 | Clamp-Switch |
| 17 | 3296-56 | 6 | Nut-Nyloc 1/4-20 Thin | 42 | 116-2832 | 2 | Actuator-Switch, Reed |
| 18 | 114-0249 | 1 | Spring-Extension | 43 | 52-2480 | 2 | Spacer-Wheel |
| 19 | 116-4276 | 1 | Control-Throttle | | | | |

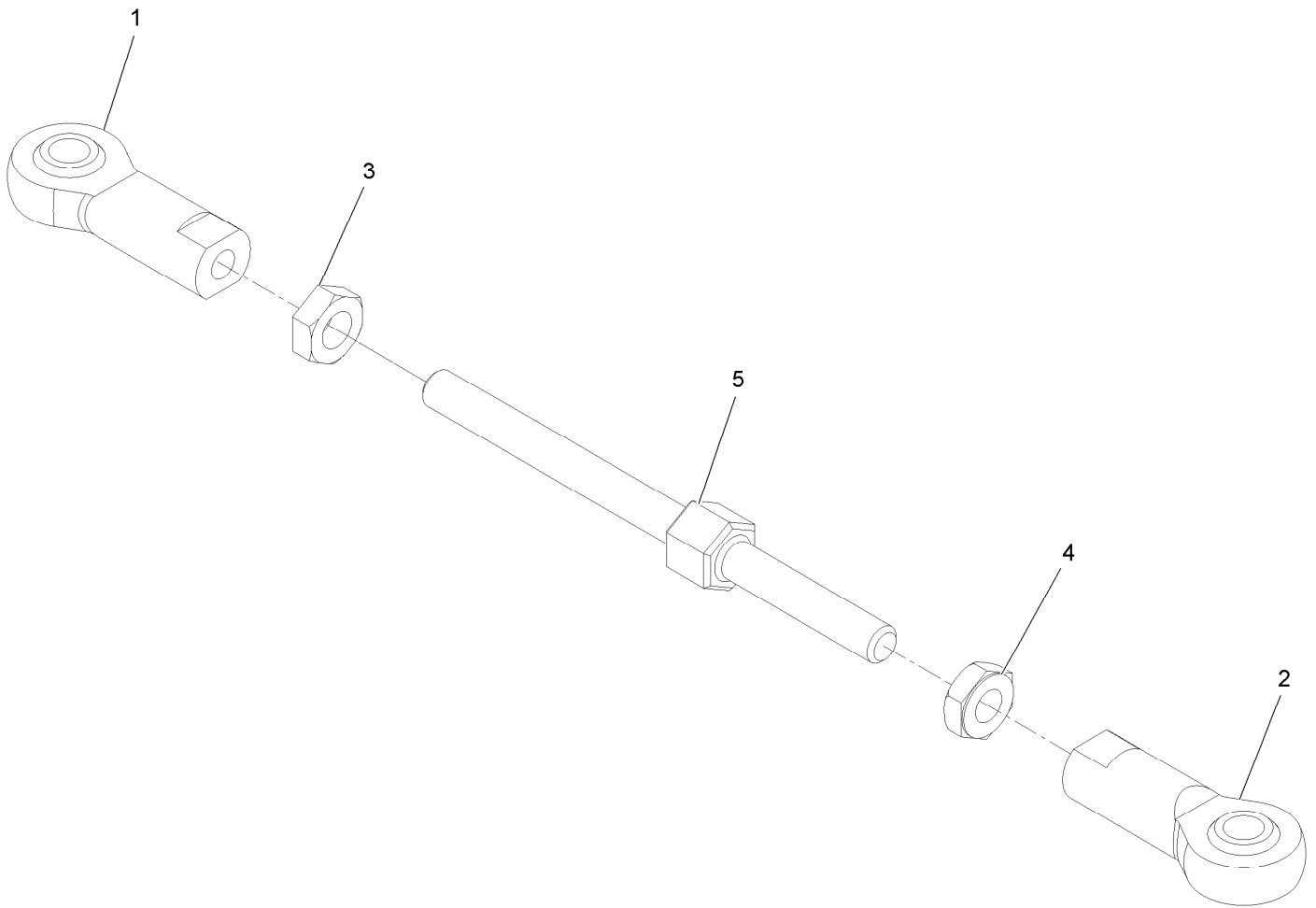

Vertical Adjust Link Assembly No. 116-4210

| <i>Ref.</i> | <i>Part Number</i> | <i>Qty.</i> | <i>Description</i> |
|-------------|--------------------|-------------|---------------------|
| 1 | 2411-41 | 1 | Rod End-Ball Joint |
| 2 | 104-4013 | 1 | Joint-Ball, LH |
| 3 | 3220-1 | 1 | Nut-Jam 1/4-28 |
| 4 | 104-3941 | 1 | Nut-Jam |
| 5 | 116-4209 | 1 | Rod-Vertical Adjust |

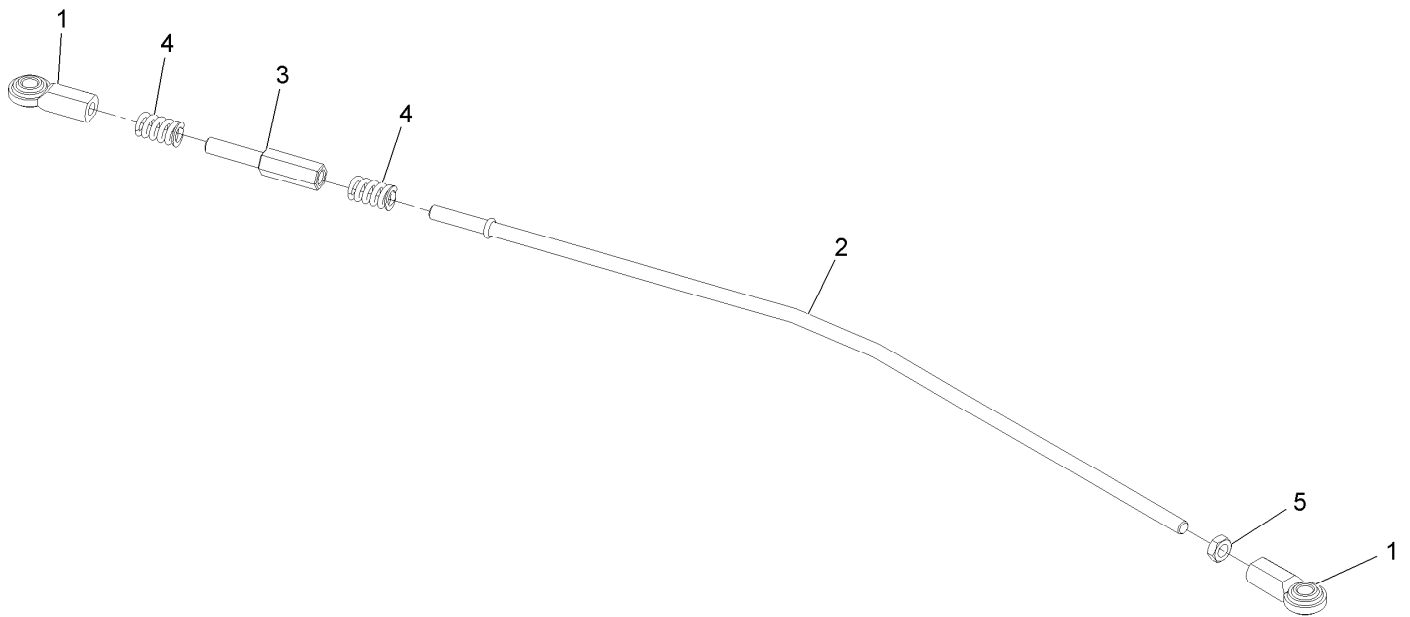

LH Tracking Control Linkage Assembly No. 116-4213

| <i>Ref.</i> | <i>Part Number</i> | <i>Qty.</i> | <i>Description</i> |
|-------------|--------------------|-------------|----------------------------|
| 1 | 103-0608 | 2 | Balljoint |
| 2 | 116-4742 | 1 | Link-Lower, Motion Control |
| 3 | 116-4755 | 1 | Rod-Adjustment |
| 4 | 116-7560 | 2 | Spring-Compression |
| 5 | 3220-3 | 1 | Nut-Jam 3/8-24 |

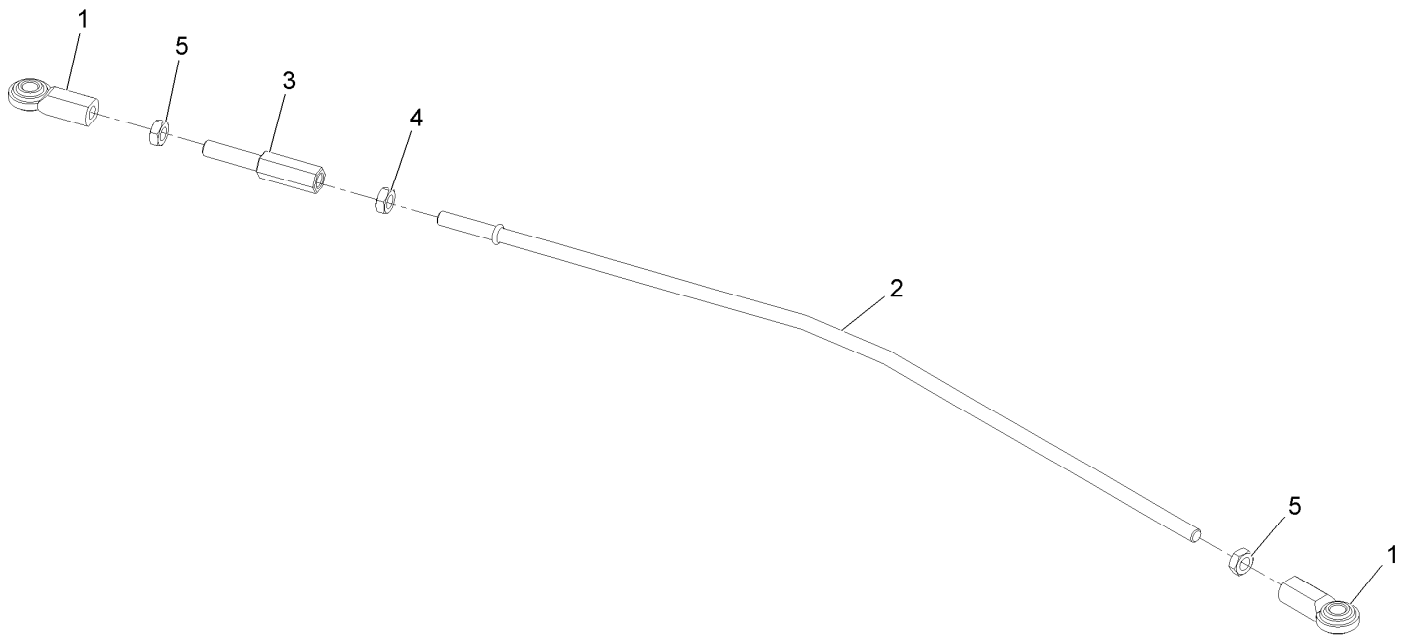

RH Tracking Control Linkage Assembly No. 116-4214

| <i>Ref.</i> | <i>Part Number</i> | <i>Qty.</i> | <i>Description</i> |
|-------------|--------------------|-------------|----------------------------|
| 1 | 103-0608 | 2 | Balljoint |
| 2 | 116-4742 | 1 | Link-Lower, Motion Control |
| 3 | 116-4755 | 1 | Rod-Adjustment |
| 4 | 3220-16 | 1 | Nut-Jam 3/8-24 LH |
| 5 | 3220-3 | 2 | Nut-Jam 3/8-24 |

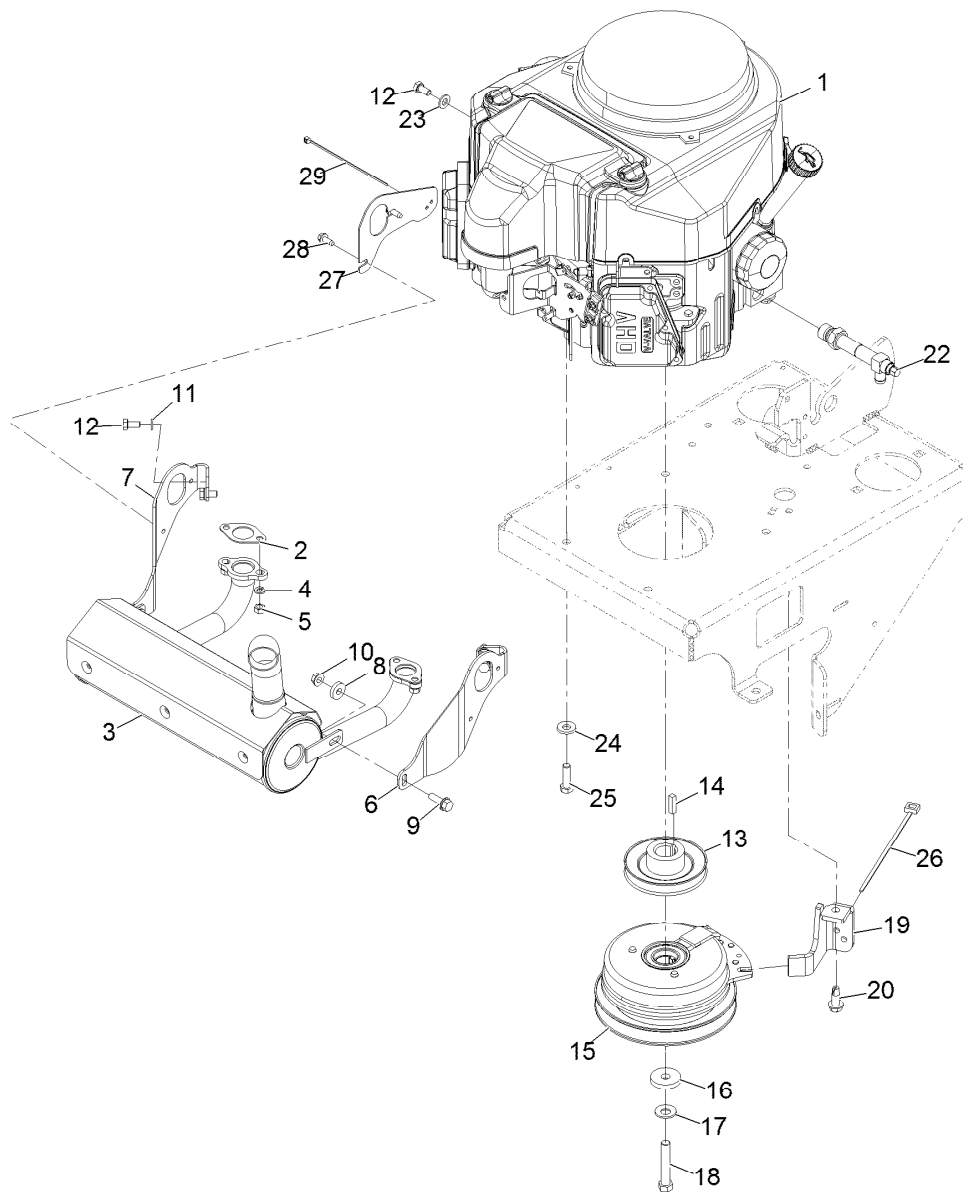

Engine Assembly

| Ref. | Part Number | Qty. | Description |
|------|-------------|------|-------------------------------|
| 1 | | 1 | Engine-Kawasaki, Fs541V ■◆ |
| 2 | 1-653313 | 2 | Gasket-Exhaust |
| 3 | 116-8746 | 1 | Muffler |
| 4 | 114-3550 | 4 | Washer-Lock, Spring |
| 5 | 114-3549 | 4 | Nut-M8 |
| 6 | 116-4752 | 1 | Bracket-Muffler Mount, LH |
| 7 | 116-4750 | 1 | Bracket-Muffler Mount, RH |
| 8 | 104-7658 | 2 | Spacer |
| 9 | 3234-29 | 2 | Screw-HH Flg 5/16-18 X 1 |
| 10 | 32128-25 | 2 | Nut-Hex 5/16-18 Side Lock |
| 11 | 3253-4 | 4 | Washer-Lock 5/16 |
| 12 | 33114-016 | 5 | Screw-HH M8-1.25 X 16Mm |
| 13 | 116-3610 | 1 | Pulley ▲ |
| 14 | 1-807259 | 1 | Key-Machine 1/4 X 1/4 X 1 |

| Ref. | Part Number | Qty. | Description |
|------|-------------|------|----------------------------|
| 15 | 116-4395 | 1 | Clutch-175 Ft-Lb ▲ |
| 16 | 107-4136 | 1 | Washer |
| 17 | 1-603610 | 1 | Washer-Spring Disc 7/16 |
| 18 | 3212-10 | 1 | Screw-HH 7/16-20 X 2 1/2 ○ |
| 19 | 116-3565-01 | 1 | Anchor-Clutch |
| 20 | 105-6245 | 1 | Screw-Tapping |
| 22 | 116-6126 | 1 | Valve-Drain Oil □ |
| 23 | 33094-00 | 1 | Washer |
| 24 | 98-5975 | 4 | Washer-Spring Disc 3/8 |
| 25 | 323-7 | 4 | Screw-HH 3/8-16 X 1 1/4 |
| 26 | 3290-378 | 1 | Tie-Cable |
| 27 | 116-4751 | 1 | Guard-Cable, Spark Plug |
| 28 | 32144-10 | 2 | Screw-HWH 1/4-20 X .62 |
| 29 | 1-303287 | 1 | Tie-Cable 5 1/2 (Small) |
| 99 | 103-1964 | 1 | Hose-Drain, Oil ● |

● Not illustrated

▲ Apply anti-seize compound in bore.

□ Use a Teflon Pipe Sealant or equivalent on threads.

○ Use Pro-Lock, Nut Type (P/N 1-840022, .5ml tube) on threads.

■ Not serviced separately

◆ Obtain parts from www.kawpowerepc.com

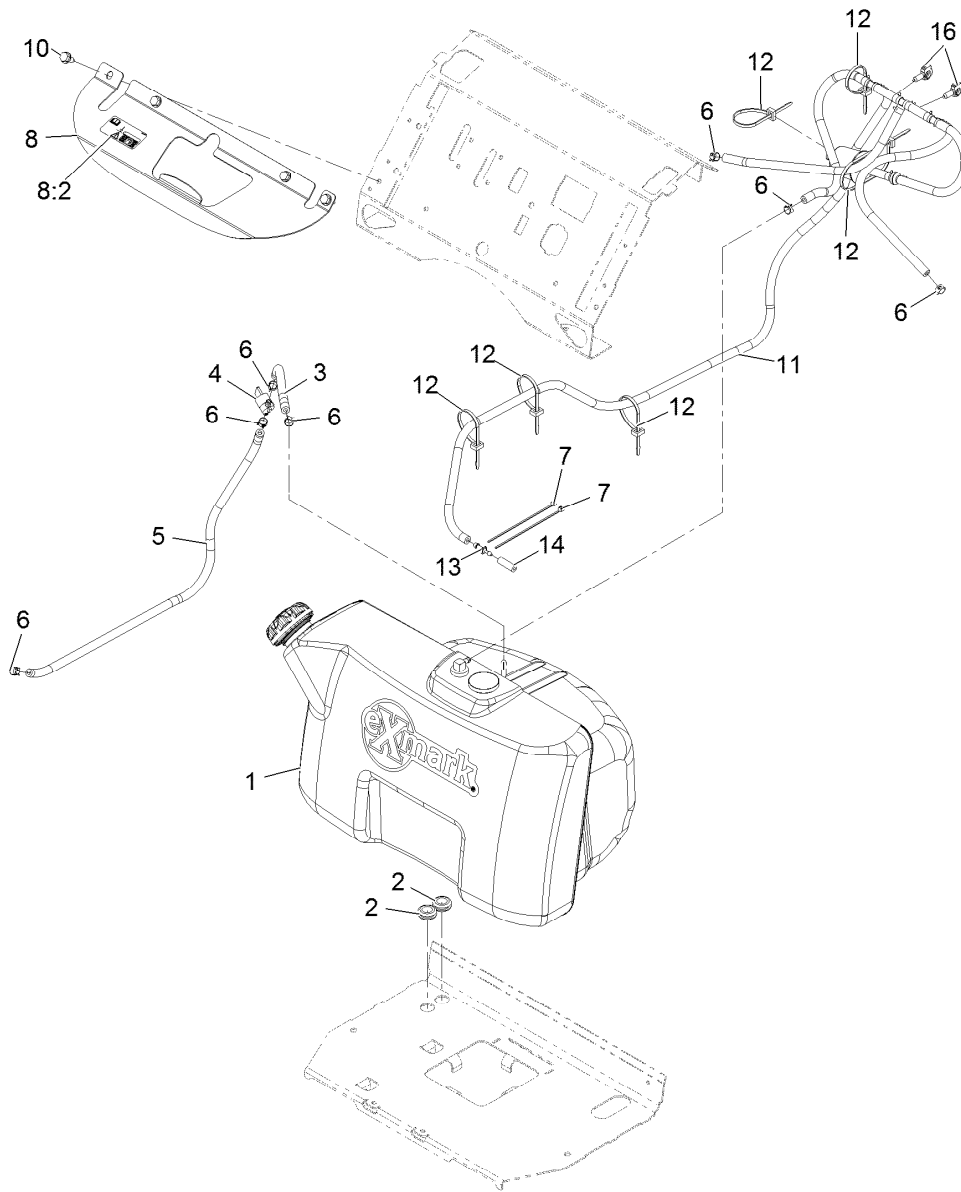

Fuel Tank Mounting Assembly

| Ref. | Part Number | Qty. | Description |
|------|-------------|------|----------------------------|
| 1 | 116-4577 | 1 | Tank ASM- Exmark |
| 2 | 112-7069 | 2 | Grommet |
| 3 | 107-9297 | 1 | Hose-Fuel |
| 4 | 1-603770 | 1 | Valve-Fuel |
| 5 | 110-1872 | 1 | Hose-Fuel |
| 6 | 2412-98 | 7 | Clamp-Hose |
| 7 | 1-303287 | 2 | Tie-Cable 5 1/2 (Small) |
| 8 | 116-3088 | 1 | Bracket-Tank |
| 8:2 | 116-8775 | 1 | Decal-Fuel Fill |
| 10 | 32144-70 | 4 | Screw-HWH 5/16-18 X 3/4 Tf |
| 11 | 116-4636 | 1 | Vent ASM |
| 12 | 3290-378 | 6 | Tie-Cable |
| 13 | 106-8150 | 1 | Fitting-Straight |
| 14 | 51-3216 | 1 | Hose-Fuel |
| 16 | 32180-040 | 2 | Clip-Harness |

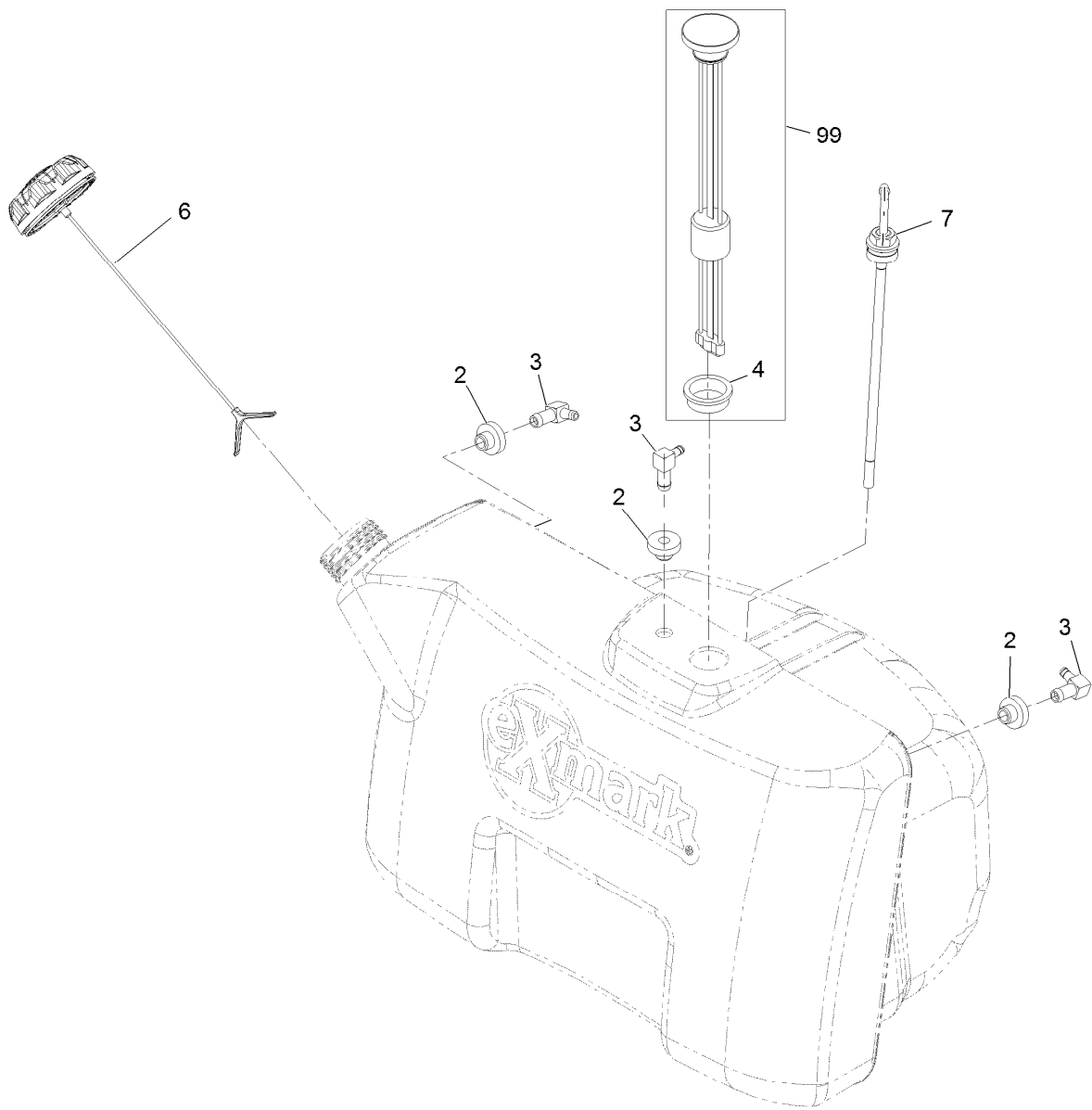

Fuel Tank Assembly No. 116-4577

| <i>Ref.</i> | <i>Part Number</i> | <i>Qty.</i> | <i>Description</i> |
|-------------|--------------------|-------------|------------------------------------|
| 2 | 46-6560 | 3 | Bushing |
| 3 | 1-643172 | 3 | Elbow-90 DEG |
| 4 | 95-8972 | 1 | Grommet |
| 6 | 126-1789 | 1 | Cap-Fuel, Ratcheting |
| 7 | 116-3408 | 1 | Fitting-Fuel, Bulkhead |
| 99 | 116-7264 | 1 | Kit, Vantage Fuel Gage Replacement |

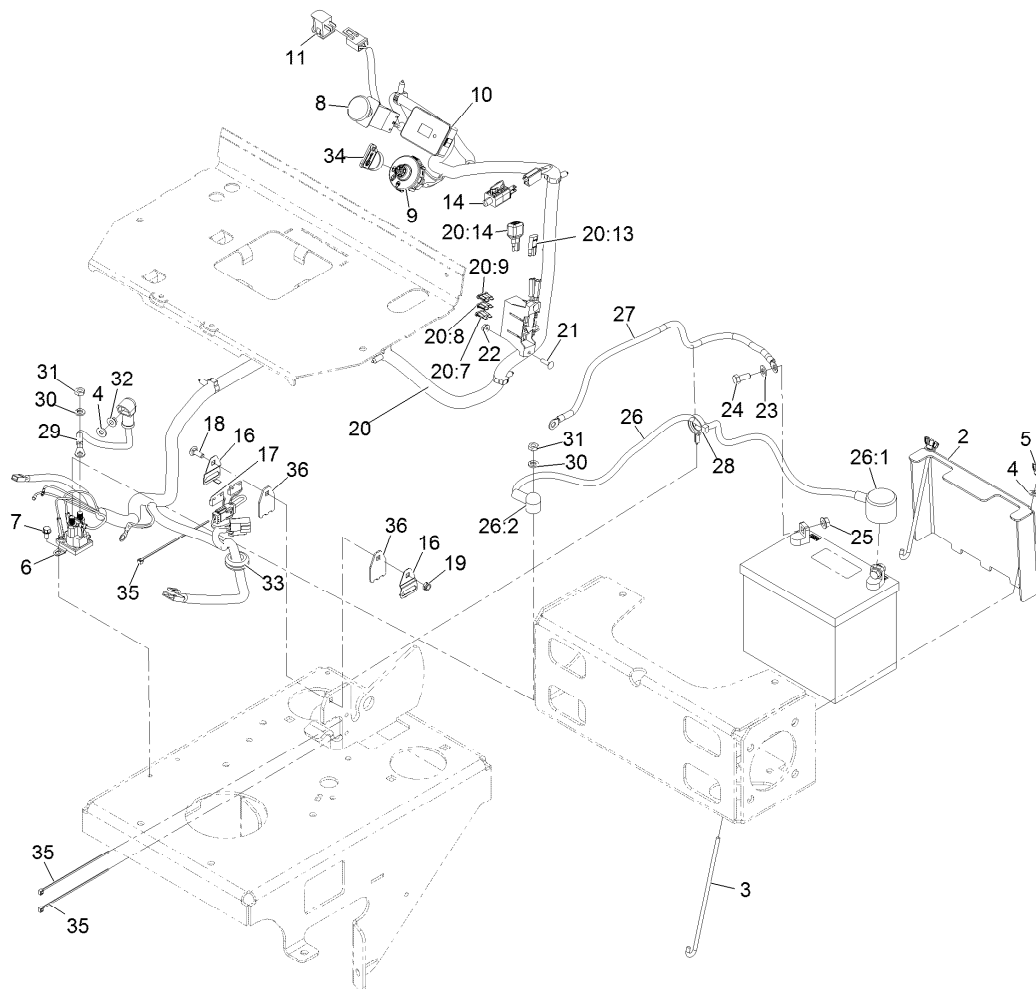

Electrical Assembly

| <i>Ref.</i> | <i>Part Number</i> | <i>Qty.</i> | <i>Description</i> | <i>Ref.</i> | <i>Part Number</i> | <i>Qty.</i> | <i>Description</i> |
|-------------|--------------------|-------------|-----------------------------------|-------------|--------------------|-------------|-------------------------|
| 2 | 116-4756-01 | 1 | Cover-Battery | 20:13 | 116-0053 | 1 | Cap-Plug |
| 3 | 1-633651 | 2 | Bolt-Holddown | 20:14 | 103-3895 | 1 | Diode-Tvs |
| 4 | 3256-22 | 3 | Washer-1/4 Sae | 21 | 3229-20 | 2 | Screw-CARR |
| 5 | 1-543792 | 2 | Wingnut-Nyloc 1/4-20 | 22 | 3290-148 | 2 | Nut-Whizlock #10-24 |
| 6 | 117-1197 | 1 | Solenoid | 23 | 3256-23 | 2 | Washer-5/16 Sae |
| 7 | 32144-4 | 2 | Screw-HWH 1/4-20 X 1/2 Taptite | 24 | 322-3 | 2 | Screw-HH 5/16-18 X 3/4 |
| 8 | 114-0279 | 1 | Switch-PTO | 25 | 109-5715 | 2 | Nut-Hex Flange 5/16-18 |
| 9 | 117-2222 | 1 | Switch-Ignition | 26 | 109-7608 | 1 | Cable, Battery (+) |
| 10 | 117-3886 | 1 | Module-Hour Meter | 26:1 | 109-2407 | 1 | Insulator-Battery |
| 11 | 82-2190 | 1 | Switch | 26:2 | 1-543393 | 1 | Insulator-Solenoid |
| 14 | 119-8231 | 1 | Switch-Plunger, Nc, Spst | 27 | 54-3093 | 1 | Cable-Battery, Negative |
| 16 | 116-4739 | 2 | Clamp-Switch | 28 | 105-1853 | 1 | Clamp-Hose |
| 17 | 116-2833 | 1 | Harness-Switch, Reed | 29 | 106-8268 | 1 | Cable-Battery, Red |
| 18 | 3229-1 | 1 | Bolt-Carriage 1/4-20 X 3/4 | 30 | 3253-4 | 2 | Washer-Lock 5/16 |
| 19 | 3296-56 | 1 | Nut-Nyloc 1/4-20 Thin | 31 | 3220-2 | 2 | Nut-Jam 5/16-24 |
| 20 | 126-1214 | 1 | Harness, Wire ● | 32 | 32128-33 | 1 | Nut-Whizlock 1/4-20 |
| 20:7 | 109103 | 1 | Fuse-Blade, 30 Amp | 33 | 117-2781 | 1 | Grommet |
| 20:8 | 109102 | 1 | Fuse-Blade, 25 Amp | 34 | 103-2106 | 1 | Key-Exmark Logo |
| 20:9 | 218-578 | 1 | Fuse-Blade, 10 Amp | 35 | 1-303287 | 3 | Tie-Cable 5 1/2 (Small) |
| | | | | 36 | 116-4388 | 2 | Plate-Spacer |

● Use dielectric grease on all unsealed connectors and terminals only. Do not apply in sealed connectors.

Notes:

EXMARK® MAINTENANCE

MAXIMIZE THE PERFORMANCE OF YOUR EXMARK.

4-CYCLE PREMIUM ENGINE OIL

Part No. 116-3373

Both SAE 30 and SAE 10W-30 in one bottle.

Contains increased levels of zinc and phosphorus for better lubricity.

No Viscosity Index Improvers that tend to shear down in high heat.

Synthetic formulation.

Gas & Diesel compatible.

Anti-corrosion additives.

API 'SL' and JASO rated with wet clutch compatibility for other machines.

PREMIUM HYDRO OIL

Part No. 109-9828

Commercial quality for tough, high-heat conditions.

Designed specifically for zero-turn mower hydraulic systems.

Superior shear resistance under heavy loads.

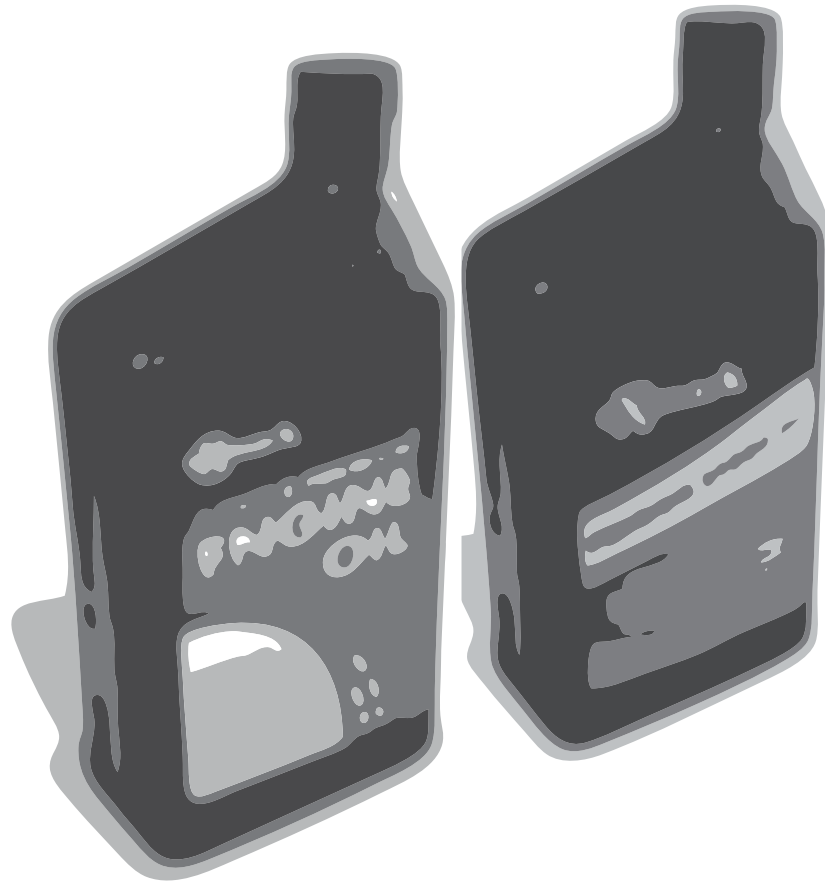

Available from your local Exmark dealer. Find your closest dealer at exmark.com

EXMARK ACCESSORIES AND OPTIONS*

MID-MOUNT RIDING ACCESSORIES AND OPTIONS

| | |
|------------------------------------|---------------------------------|
| CUSTOM RIDE SEAT SUSPENSION SYSTEM | OPERATOR CONTROLLED DISCHARGE |
| FULL SUSPENSION SEAT | SUN SHADE |
| DECK LIFT ASSIST KIT | TRASH CONTAINER |
| HITCH KIT | TURF STRIPER |
| LIGHT KIT | ULTRA VAC COLLECTION SYSTEM |
| 12V POWER PORT | ULTRA VAC QUICK DISPOSAL SYSTEM |
| MICRO-MULCH SYSTEM | |

OUT-FRONT RIDING ACCESSORIES AND OPTIONS

| | |
|------------------------------------|---------------------------------|
| CUSTOM RIDE SEAT SUSPENSION SYSTEM | SNOW BLADE |
| DUAL-TAIL WHEEL | SNOWBLOWER |
| FLOOR PAN EXTENDER | SUN SHADE |
| HITCH KIT | TRASH CONTAINER |
| LIGHT KIT | ULTRA VAC COLLECTION SYSTEM |
| MICRO-MULCH SYSTEM | ULTRA VAC QUICK DISPOSAL SYSTEM |
| ROLL OVER PROTECTION SYSTEM (ROPS) | WEATHER CAB |

WALK-BEHIND ACCESSORIES AND OPTIONS

| | |
|--------------------|--------------|
| GRASS CATCHER | TURF STRIPER |
| MICRO-MULCH SYSTEM | STANDON |

*Some accessories and options not available for some models.

Place Model No. and Serial No.
Label Here (Included in the Literature
Pack) or Fill in Below

Model No. _____

Serial No. _____

Date Purchased _____

Engine Model No. and Spec. No. _____

Engine Serial No. (E/No) _____

© 2014 Exmark Mfg. Co., Inc.
Industrial Park Box 808
Beatrice, NE 68310
All Rights Reserved

Part No. 4501-807 Rev. A
(402) 223-6300
Fax (402) 223-5489
Printed in the USA.



www.exmark.com