

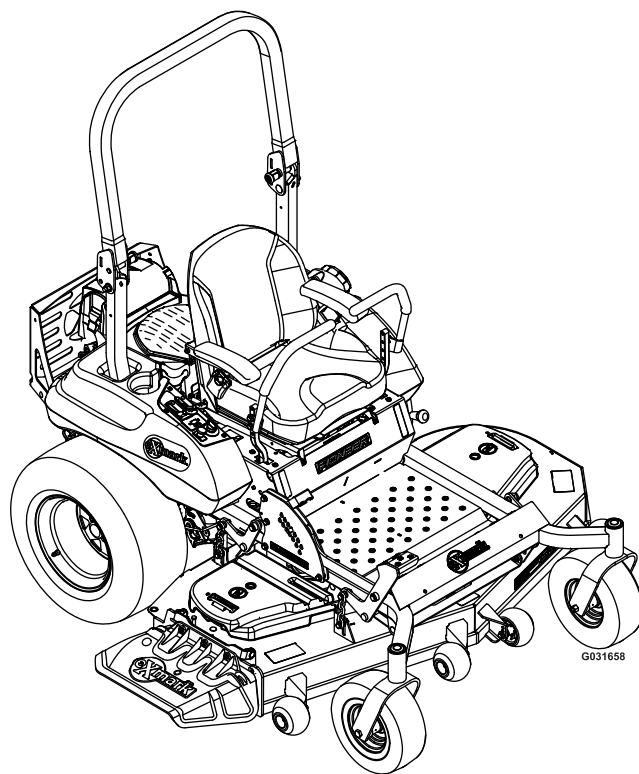

PIONEER®

Model No. PNS730GKA604A3—Serial No. 31600000 and Up

Picture below may not reflect actual product.



Parts Manual

Part No. 4502-661 Rev. A

Ordering Replacement Parts

To order replacement parts, please supply the part number, the quantity, and the description of each part desired.

Understanding Reference Numbers

Each identified part in an illustration has a reference number. The reference number for a part also appears in the parts list, along with other information about the part.

This catalog uses two special reference number formats, one to indicate parts in a service assembly and another to indicate the quantity of a given part in an illustration.

Service Assembly Reference Numbers

Parts in service assemblies have reference numbers in the form a:b. The a represents the reference number of the entire service assembly and the b represents a sequential number unique to each part within the service assembly.

For example, a wheel assembly might be identified by reference number 6, the tire by 6:1, the valve by 6:2, and the wheel by 6:3. When you order the assembly identified by reference number 6, you receive all parts identified by reference numbers 6:1, 6:2, and 6:3. However, you may also order any part individually. Reference numbers of this type appear in illustration and in parts lists.

Reference Numbers Indicating Quantity

In an illustration, if a reference number indicates more than one part, the reference number has the form nX y. The n represents the quantity of the part, the X is the multiplication symbol, and the y represents the reference number.

For example, in an illustration, the reference number 2X 37 means that two of the parts identified by reference number 37 are indicated.

List of Abbreviations

AR: as required	HLH: hex lag head	PTH: phillips truss head
ASM: assembly	HOC: height-of-cut	PTO: power-take-off
BBC: blade brake control	HP: high pressure	RH: right hand
BHTF: button head thread forming	HSBH: hex socket button head	ROPS: roll-over protection system
CARR: carriage	HSFH: hex socket flat head	RRB: rear roller brush
CCW: counter clockwise	HSH: hex socket head	SFH: slotted fillister head
CW: clockwise	HWH: hex washer head	SHH: slotted hex head
DEG: degrees	HWHTF: hex washer head thread forming	SHWH: slotted hex washer head
DPA: Dual Point Adjustment	HYD: hydraulic	SPH: slotted pan head
ECM: electronic control module	LH: left hand	SQH: square head
EXT: external	LP: low pressure	SRH: slotted round head
FH: flat head	LPG: Liquefied Petroleum Gas	STD: standard
GA: gauge	NI: nylon insert	TAP: self tapping
HD: heavy-duty	NPTF: national pipe thread fine	TTH: torx truss head
HF: hex flange	PFH: phillips flat head	
HH: hex head	PPH: phillips pan head	
HHF: hex head flange	PPHTF: phillips pan head thread forming	
HHFTF: hex head flange thread forming	PRH: phillips round head	
HJ: hex jam		

Touch Up Paint

Exmark black touch up spray paint – gloss black.

Exmark red touch up paint (spray paint – P/N 1-850337 - .6 oz liquid bottle – P/N 103-9140).



If your Exmark dealer does not have the Exmark part in stock, Exmark will get the parts to the dealer the next business day or the part will be FREE Guaranteed!! (Some restrictions apply. See your participating Exmark Dealer for details.)

Contents

Complete Deck Assembly	4
Deck Assembly	6
Deck W/Decals Assembly No. 116-5812	8
Idler Arm W/Bearings Assembly	10
Main Frame Assembly	12
Main Frame W/Decals Assembly	14
Caster Wheel Assembly No. 117-0361	16
Roll-Over Protection System Assembly No. 116-3498	18
Deck Lift Assembly	20
Motion Control Assembly	22
LH Motion Control Assembly	24
RH Motion Control Assembly	26
Seat Assembly	28
Seat W/Tracks Assembly No. 126-2802	30
Controls Assembly	32
Fuel Tank Mounting Assembly	34
Fuel Tank Assembly No. 116-4610	36
Engine Assembly	38
Hydraulic Assembly	40
RH Transaxle Assembly	42
LH Transaxle Assembly	44
Electrical Assembly	46

Complete Deck Assembly

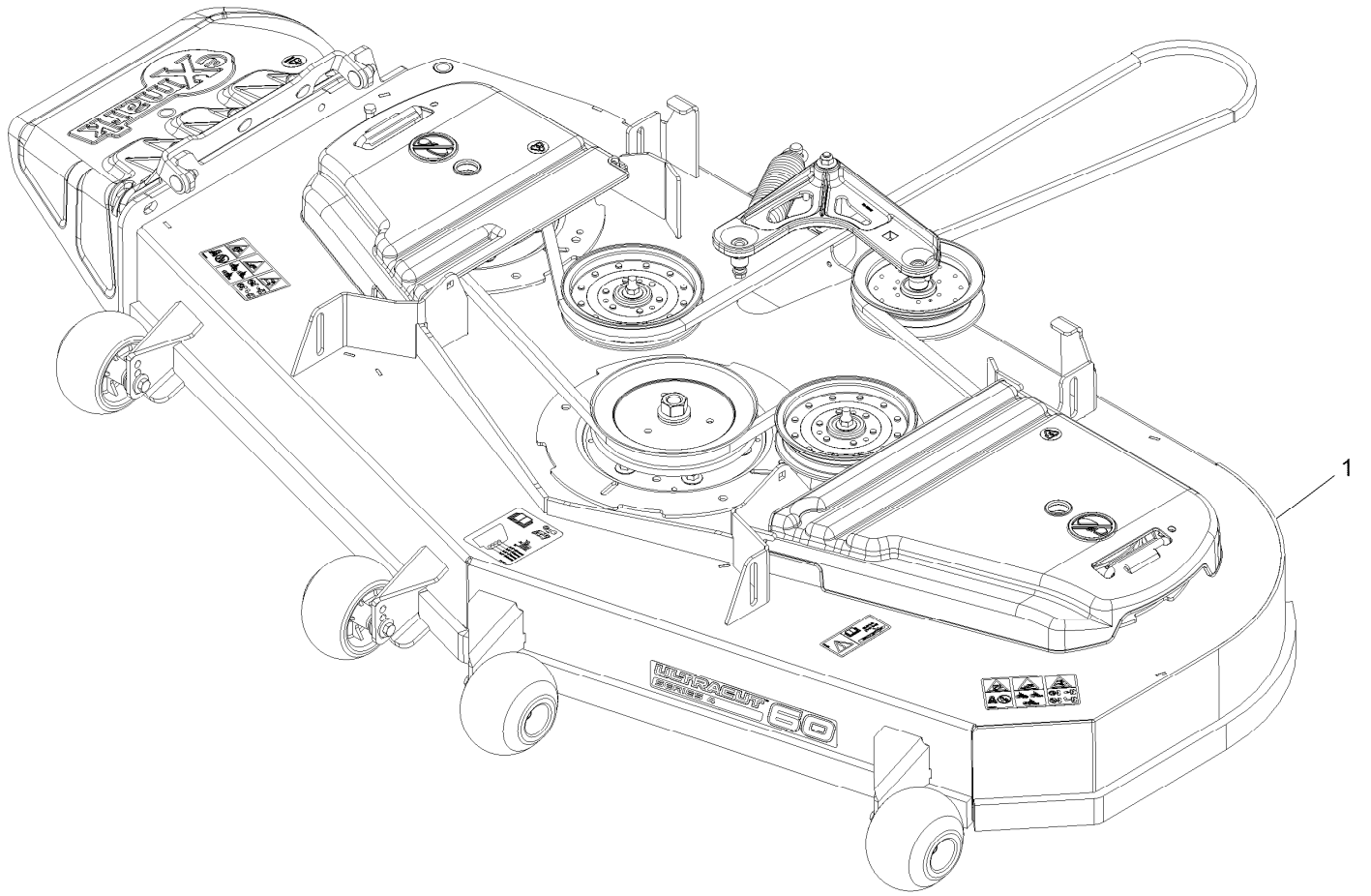

Complete Deck Assembly (continued)

<i>Ref.</i>	<i>Part Number</i>	<i>Qty.</i>	<i>Description</i>
1	116-5945	1	ASM-Deck Complete 604

Deck Assembly

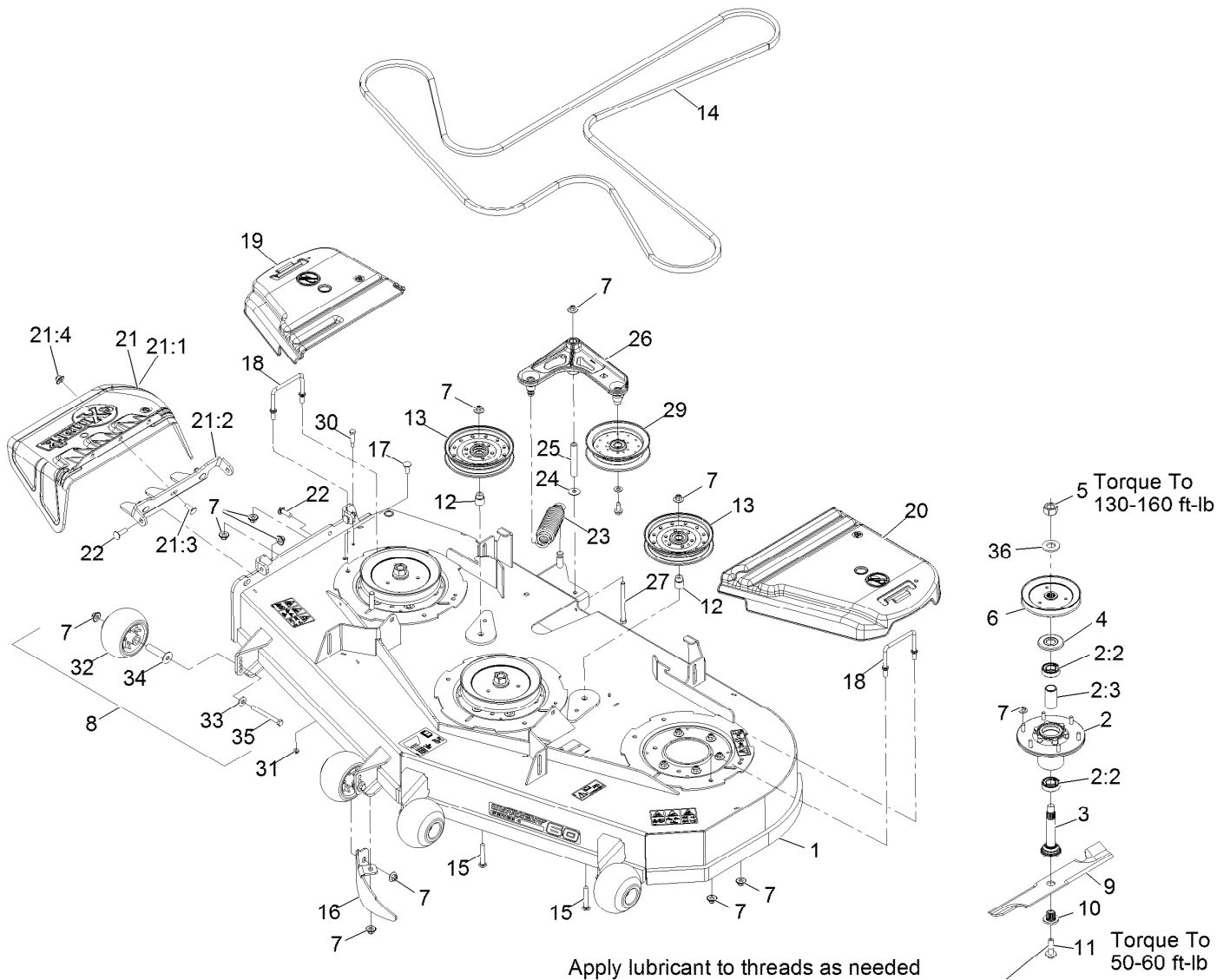

Apply lubricant to threads as needed to prevent seizing. Copper based anti-seize preferable. Grease is an acceptable substitute.

Deck Assembly (continued)

<i>Ref.</i>	<i>Part Number</i>	<i>Qty.</i>	<i>Description</i>	<i>Ref.</i>	<i>Part Number</i>	<i>Qty.</i>	<i>Description</i>
1	116-5812	1	Deck ASM,W/Decals 604	18	109-6982	2	Wireform-Cover
2	116-3344	3	ASM-Cutter Hsg With Bearings	19	116-0094	1	Cover-Belt, RH
2:2	116-0720	2	Bearing-Ball	20	109-6938	1	Cover-Belt, LH
2:3	116-3312	1	Spacer-Bearing	21	109-7188	1	ASM,Discharge Chute
3	116-3341	3	ASM-Spindle And Seal	21:1	109-2738	1	Chute, Discharge
4	116-1286	3	Guard,Bearing Top .989	21:2	109-8675-01	1	Bracket,Discharge Chute
5	116-7306	3	Nut-Hex	21:3	3231-22	3	Bolt-Carriage 3/8-16 X 1
6	116-0676	3	Sheave,Blade Drive 7.25	21:4	109-6658	3	Nut-Nyloc 3/8-16 Flg
7	109-6658	33	Nut-Nyloc 3/8-16 Flg	22	3231-28	3	Bolt-Carriage 3/8-16 X 1 1/4
8	116-9981	4	Kit, Anti-Scalp Roller	23	116-6317	1	Spring-Extension
9	116-5174	3	Blade-Extreme 2, 20.50"	24	52-2860	1	Washer
9	103-6403	3	Blade, Notched	25	116-5111	1	Bushing
9	103-6393	3	Blade, Mulching ●	26	126-0976	1	ASM-Idler Arm W/Bearings
9	103-6388	3	Blade, Low Lift	27	323-23	1	Screw-HH 3/8-16 X 4-1/2
9	103-6383	3	Blade, Solid	29	116-4668	1	Idler-Pulley, Flanged
10	103-3037	3	Bushing, Splined	30	112-8387	1	Bolt-HH Shoulder 1/4-20 X 1.64
11	109-9220	3	Screw-Sems 1/2-20 X 2.19	31	104-7201	1	Nut-Nyloc 1/4-20 Flg
12	1-633456	2	Bushing, Idler	32	103-8415	4	Roller-Anti-Scalp
13	116-4670	2	Pulley-Idler, Flat	33	98-5975	4	Washer-Spring Disc 3/8
14	114-8154	1	Belt-V	34	116-8131	4	Axle, Roller
15	3231-44	2	Bolt-Carriage 3/8-16 X 2 1/2	35	116-9362	4	Screw-HH 3/8-16 X 3 3/4 Gr 8
16	116-5614-01	1	Dogleg - Lz60	36	103-2802	3	Washer-Spring Disc 3/4
17	3231-22	1	Bolt-Carriage 3/8-16 X 1				

● Requires installation of mulch kit for proper mulching. See your Exmark dealer for details.

Deck W/Decals Assembly No. 116-5812

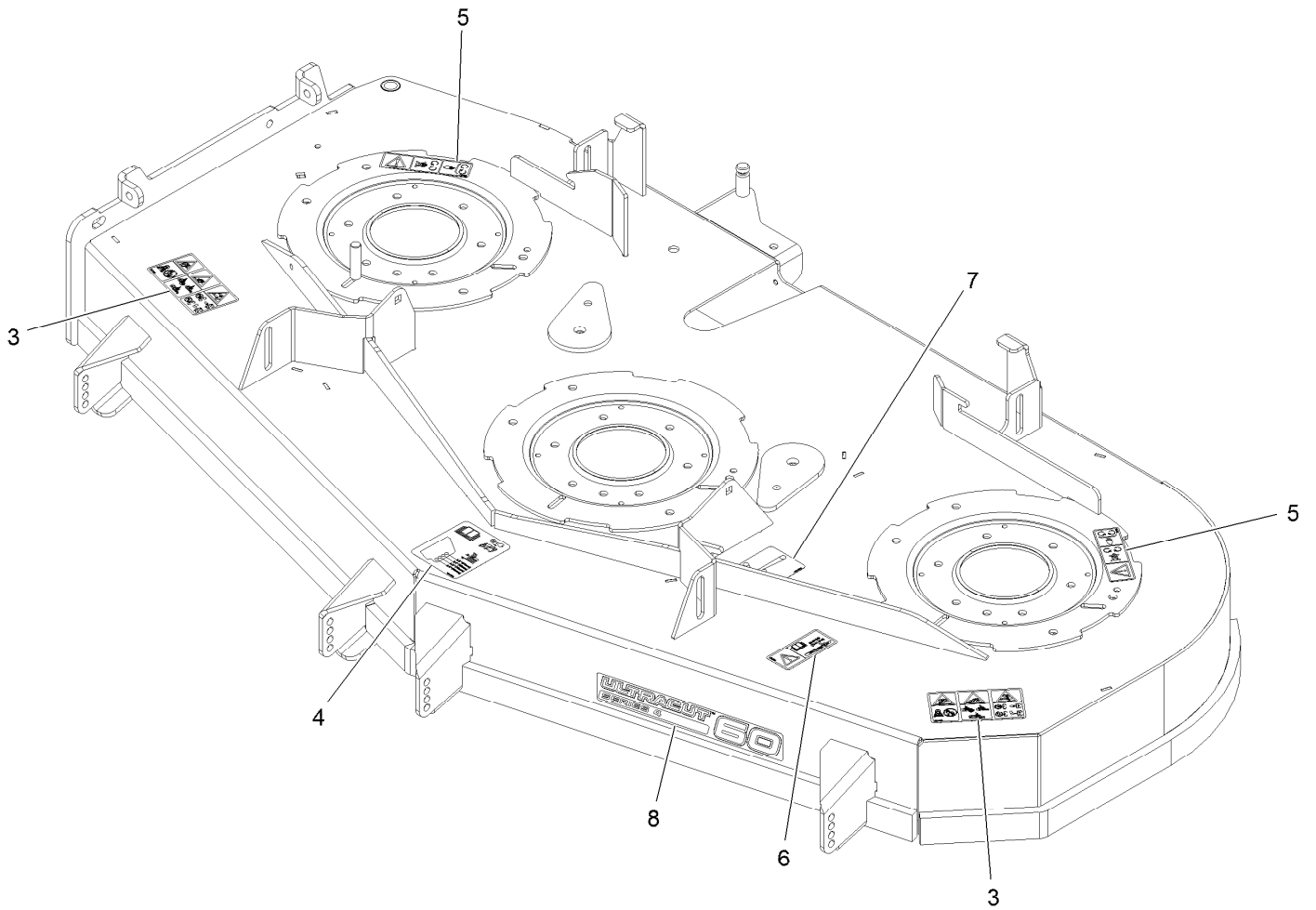

Deck W/Decals Assembly No. 116-5812 (continued)

<i>Ref.</i>	<i>Part Number</i>	<i>Qty.</i>	<i>Description</i>
3	126-6464	2	Decal-Danger Thrown Objects
4	109-6036	1	Decal-Roller, Anti-Scalp
5	112-9028	2	Decal-Missing, Cover

<i>Ref.</i>	<i>Part Number</i>	<i>Qty.</i>	<i>Description</i>
6	116-8283	1	Decal-Bolt Torque
7	109-6035	1	Decal-Belt Routing
8	126-6589	1	Decal, 604

Idler Arm W/Bearings Assembly

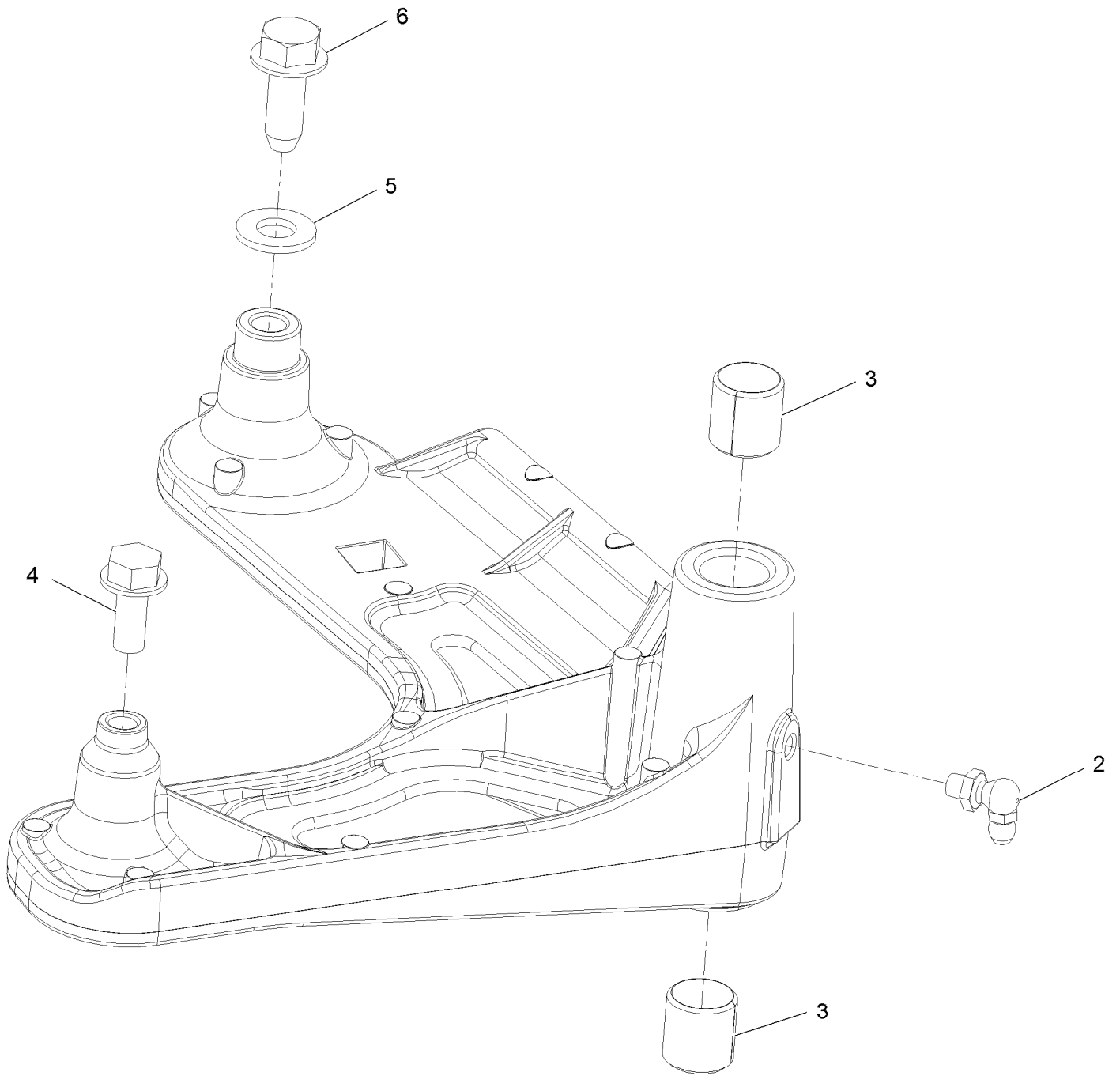

Idler Arm W/Bearings Assembly (continued)

<i>Ref.</i>	<i>Part Number</i>	<i>Qty.</i>	<i>Description</i>
2	302-40	1	Zerk-90° 1/4-28
3	1-513034	2	Sleeve-Bearing
4	32144-11	1	Screw-HWH 5/16-18 X 3/4 Tf

<i>Ref.</i>	<i>Part Number</i>	<i>Qty.</i>	<i>Description</i>
5	3256-24	1	Washer-3/8 Sae
6	126-1696	1	Screw-Thread Forming

Main Frame Assembly

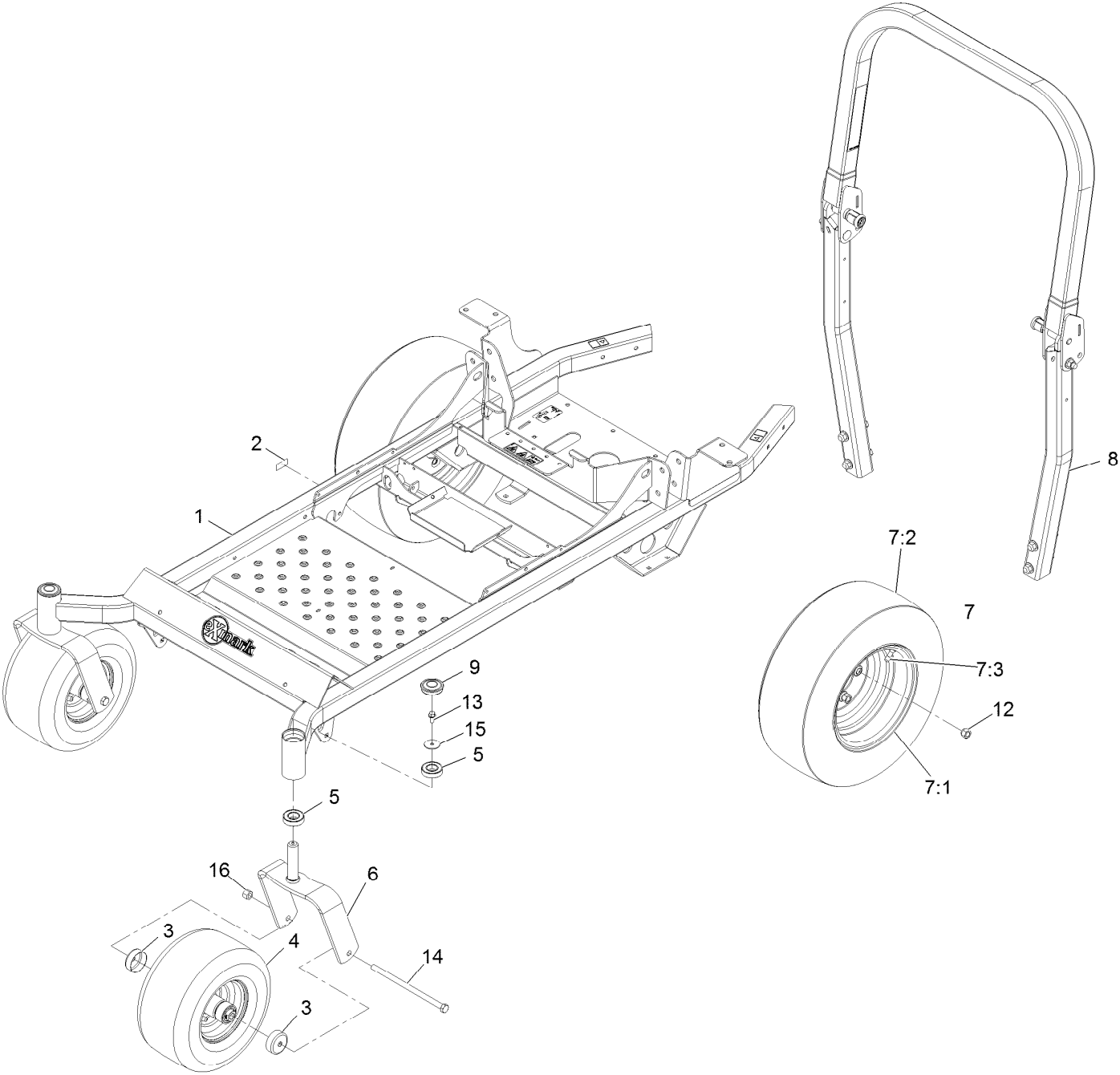

Main Frame Assembly (continued)

<i>Ref.</i>	<i>Part Number</i>	<i>Qty.</i>	<i>Description</i>	<i>Ref.</i>	<i>Part Number</i>	<i>Qty.</i>	<i>Description</i>
1	116-5854	1	Frame ASM-60	7:3	232-27	1	Stem-Valve
2	126-4345	1	Decal-Patent Ttco.Com	8	116-3498	1	ASM-ROPS Pioneer
3	103-2768	4	Guard-Seal	9	116-4348	2	Cap-Grease
4	117-0361	2	Caster Wheel ASM	12	242-50	8	Nut-Lug 1/2-20
5	109-3678	4	Bearing-Ball	13	3234-5	2	Screw-HH Flg 5/16-18 X 3/4
6	126-3997-01	2	Caster Fork Wide [red]	14	325-39	2	Screw-HH 1/2-13 X 9 1/2
7	119-2685	2	Wheel And Tire ASM	15	3256-68	2	Washer-Flat
7:1	120-3272	1	Wheel	16	3296-23	2	Nut-Nyloc 1/2-13
7:2	120-3269	1	Tire				

Main Frame W/Decals Assembly

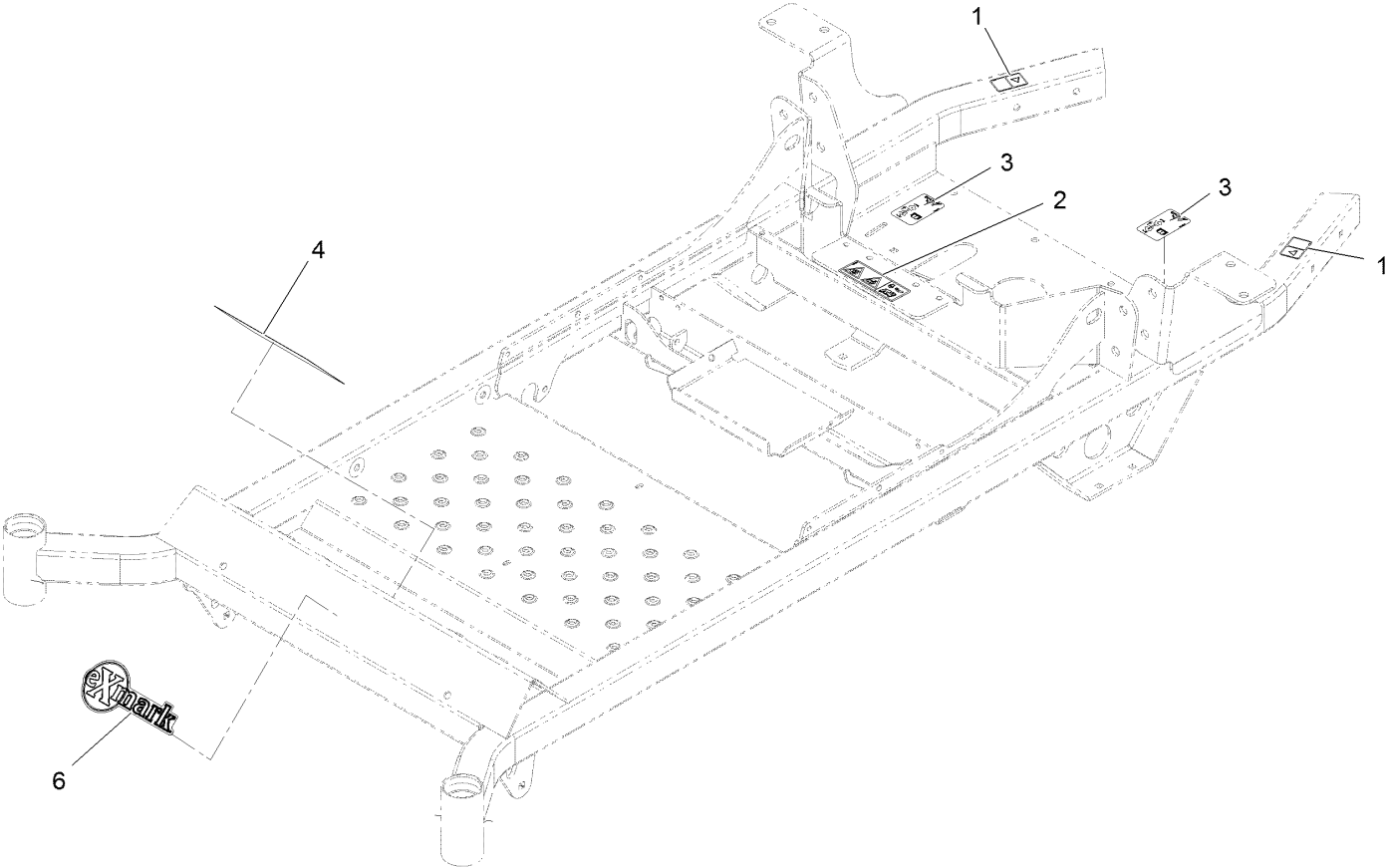

Main Frame W/Decals Assembly (continued)

<i>Ref.</i>	<i>Part Number</i>	<i>Qty.</i>	<i>Description</i>
1	106-5517	2	Decal-Warning, Hot Surface
2	126-4363	1	Decal-Warning Rotating Devices

<i>Ref.</i>	<i>Part Number</i>	<i>Qty.</i>	<i>Description</i>
3	116-8588	2	Decal-Drive Release
4	132-0871	1	Decal-Danger
6	126-6598	1	Decal, Exmark Logo

Caster Wheel Assembly No. 117-0361

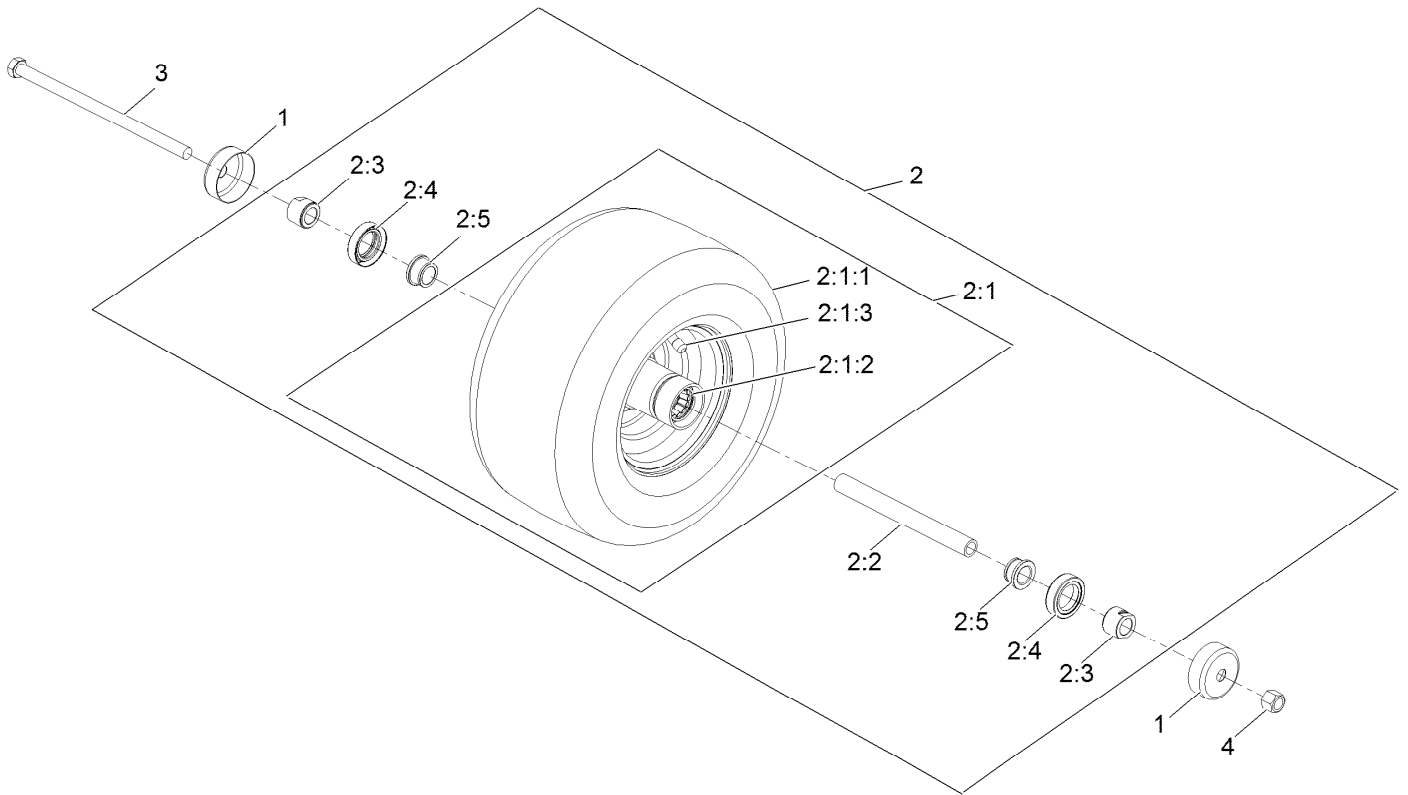

Caster Wheel Assembly No. 117-0361 (continued)

<i>Ref.</i>	<i>Part Number</i>	<i>Qty.</i>	<i>Description</i>	<i>Ref.</i>	<i>Part Number</i>	<i>Qty.</i>	<i>Description</i>
1	103-2768	2	Guard-Seal	2:3	103-3051	2	Spacer-Nut
2		1	Wheel ASM ●	2:4	103-0063	2	Seal-Double Lip
2:1		1	Wheel And Tire ASM ●	2:5	1-633585	2	Bearing-Cone Tapered Roller
2:1:1	1-523009	1	Tire	3	325-39	1	Screw-HH 1/2-13 X 9 1/2
2:1:2	1-633584	2	Bearing-Cup	4	3296-23	1	Nut-Nyloc 1/2-13
2:1:3	5108	1	Valve				
2:2	103-5156	1	Axle-Caster				

● Not serviced separately

Roll-Over Protection System Assembly No. 116-3498

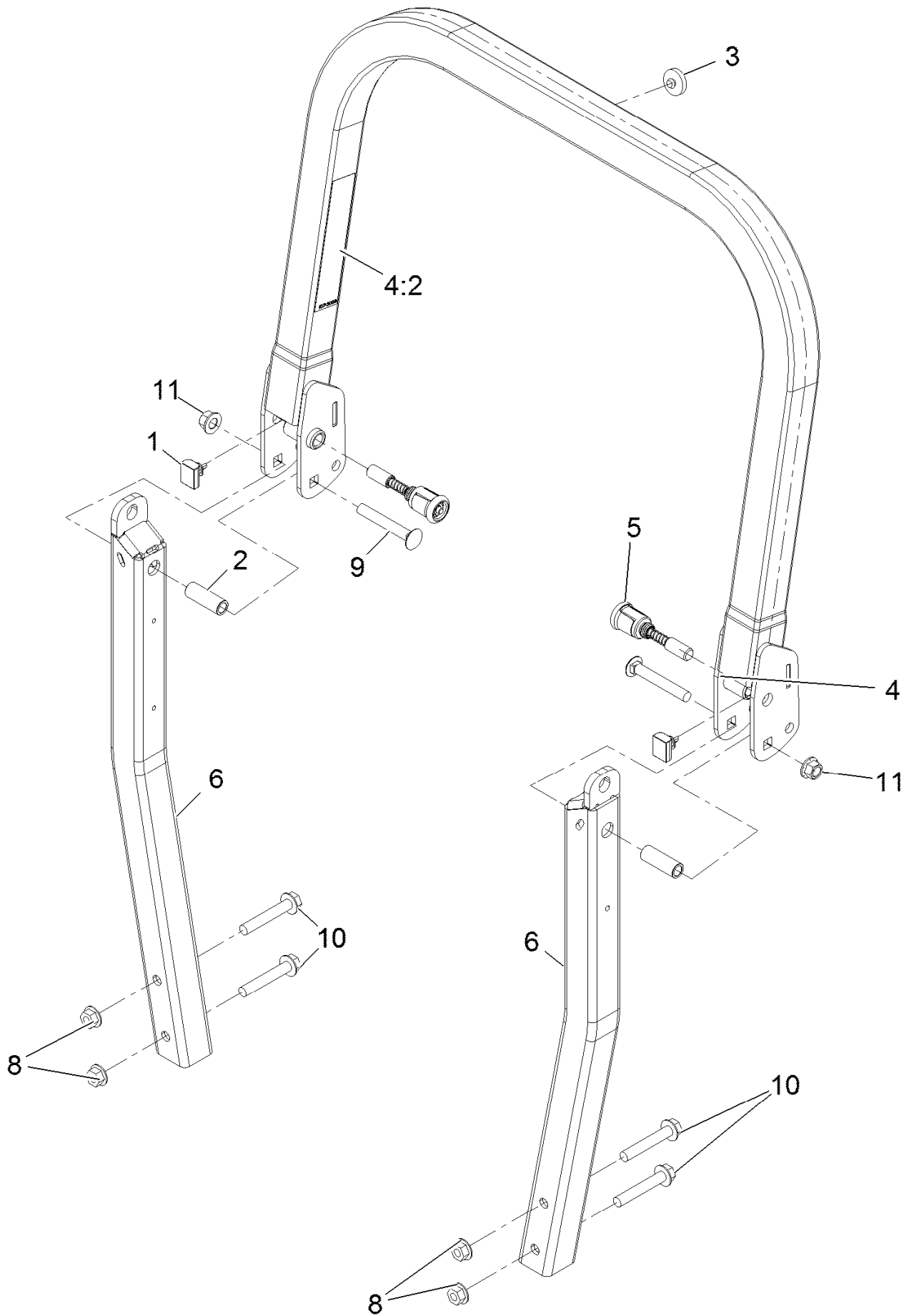

Roll-Over Protection System Assembly No. 116-3498 (continued)

<i>Ref.</i>	<i>Part Number</i>	<i>Qty.</i>	<i>Description</i>	<i>Ref.</i>	<i>Part Number</i>	<i>Qty.</i>	<i>Description</i>
1	109-5337	2	Bumper-ROPS	5	116-0104	2	Pin-Spring
2	109-6653	2	Spacer	6		2	ASM-Lwr ROPS Leg ●
3	109-9233	1	Bumper-Push-In, Rubber	8	32128-49	4	Nut-Whizlock 1/2-13
4	116-0019	1	Upper ROPS ASM	9	3233-10	2	Bolt-Carriage 1/2-13 X 3 1/2
4:2	107-3069	1	Decal-Warning, Folding ROPS	10	3234-40	4	Screw-HF
				11	99-5107	2	Nut-Lock 1/2-13

● Not serviced separately

Deck Lift Assembly

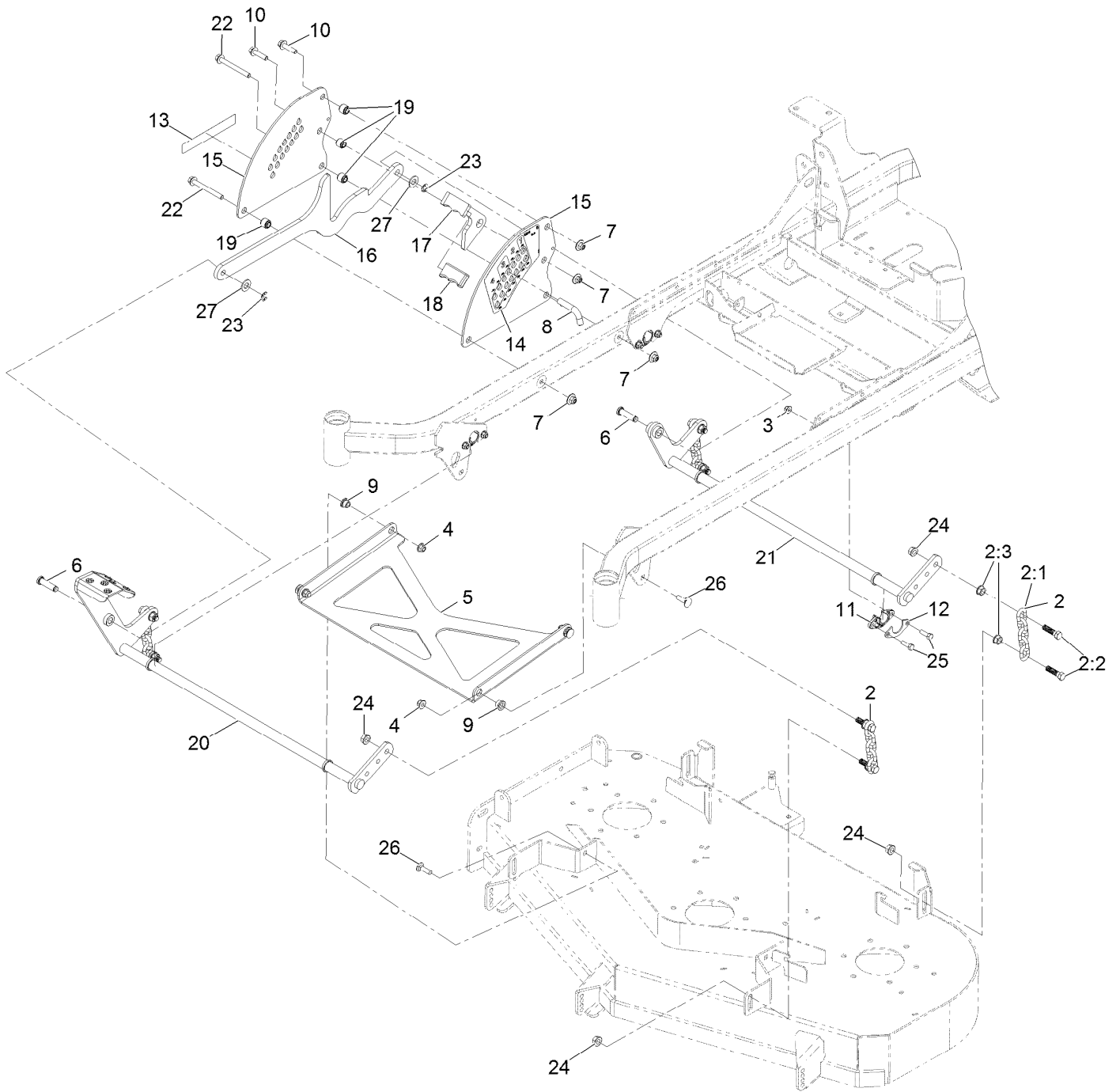

Deck Lift Assembly (continued)

<i>Ref.</i>	<i>Part Number</i>	<i>Qty.</i>	<i>Description</i>	<i>Ref.</i>	<i>Part Number</i>	<i>Qty.</i>	<i>Description</i>
2	103-9817	4	Deck Chain ASM	13	126-6998	1	Decal-S-Series
2:1	1-633447	1	Chain-Lift, Deck	14	126-4383	1	Decal-Height Of Cut
2:2	103-1898	2	Screw-HH 7/16-20 X 1-5/8 Sp	15	116-4309-03	2	Plate,Deck Lift
2:3	32128-37	2	Nut-Whizlock 7/16-14	16	116-4310-03	1	Link-HOC
3	104-8300	8	Nut-Nyloc 5/16-18 Flg	17	116-4311	1	Transport Lock-HOC
4	104-8301	4	Nut-Nyloc 3/8-16 Flg	18	116-4312	1	Grip-Bar, Flat
5	109-3723-01	1	Strut-Deck	19	116-4313	4	Spacer-Step, Double
6	109-5819	2	Pin-Clevis	20	116-6011-03	1	Wld-Deck Lift Shaft Frt
7	109-6658	4	Nut-Nyloc 3/8-16 Flg	21	116-6012-03	1	Wld-Deck Lift Shaft Rr
8	116-5584	1	Pin-HOC	22	116-4701	2	Screw-HHF
9	109-8788	4	Bushing-Flanged	23	32120-47	2	Ring-Retaining
10	114-4681	2	Screw-HHF	24	32128-37	8	Nut-Whizlock 7/16-14
11	115-5065	4	Bushing-Flange	25	322-5	8	Screw-HH 5/16-18 X 1
12	116-2887	4	Gusset-Lift, Deck	26	3231-25	4	Bolt-Carriage 3/8-16 X 1 1/4
				27	3256-26	2	Washer-1/2 Sae

Motion Control Assembly

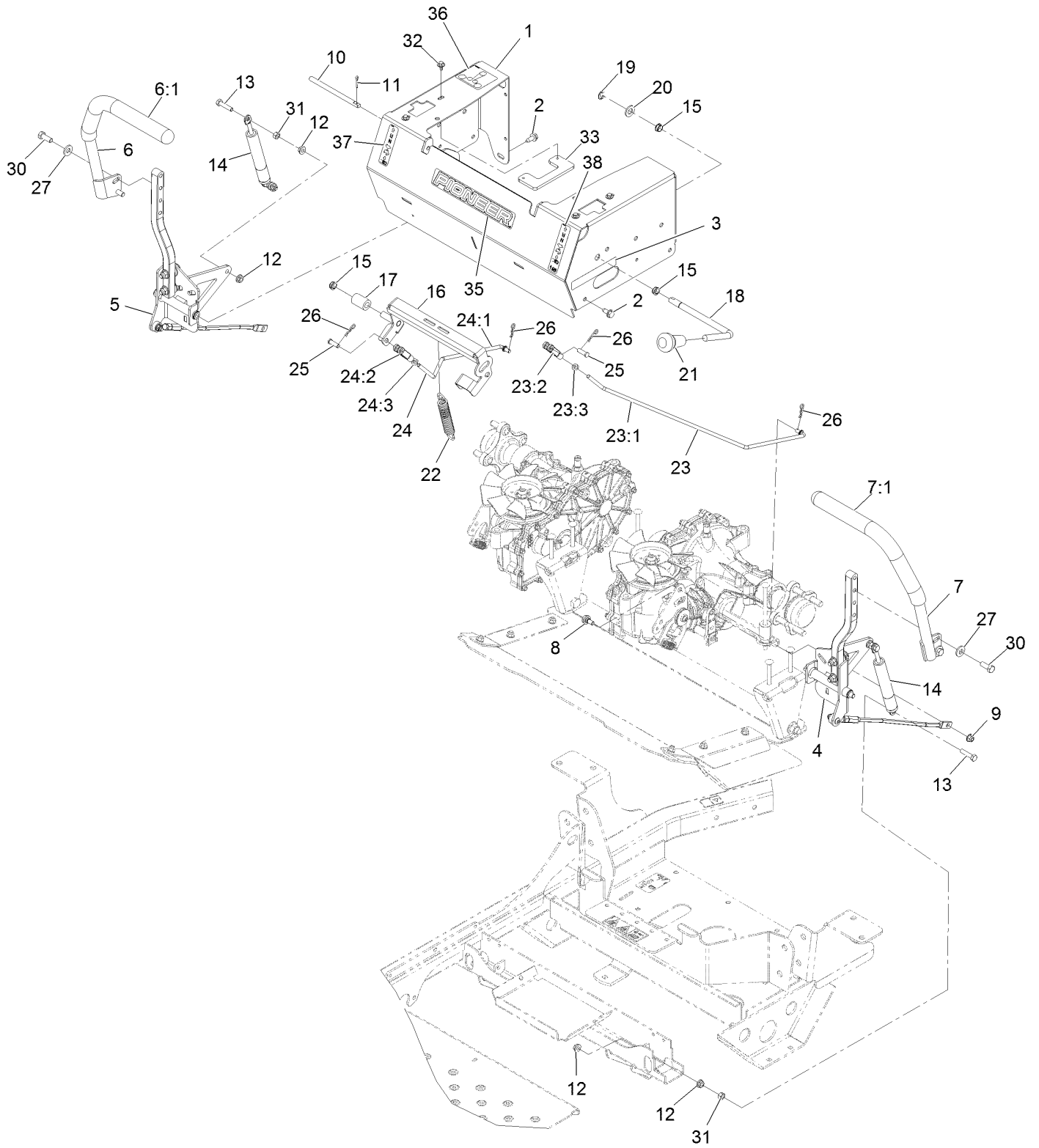

Motion Control Assembly (continued)

<i>Ref.</i>	<i>Part Number</i>	<i>Qty.</i>	<i>Description</i>	<i>Ref.</i>	<i>Part Number</i>	<i>Qty.</i>	<i>Description</i>
1	116-3188	1	ASM-Mot Ctrl Frm W/Dcl	20	106-9888	1	Washer-Flat
2	32144-70	6	Screw-HWH 5/16-18 X 3/4 Tf	21	106-7952	1	Knob
3	126-6998	1	Decal-S-Series	22	88-6130	1	Spring-Deck, Engagement
4		1	Motion Control ASM-LH ●	23	116-1165	1	Brake Linkage ASM-LH
5		1	Motion Control ASM-RH ●	23:1	116-1167	1	Linkage,Brake LH
6	119-3486	1	RH Handle ASM	23:2	1-303105	1	Yoke-Adjustable
6:1	108-6187	1	Grip	23:3	3220-2	1	Nut-Jam 5/16-24
7	119-3485	1	LH Handle ASM	24	116-1166	1	Brake Linkage ASM-RH
7:1	108-6187	1	Grip	24:1	116-1168	1	Linkage-Brake, RH
8	37-8771	2	Screw-Shoulder 5/16-18 X 5/8	24:2	1-303105	1	Yoke-Adjustable
9	104-8300	2	Nut-Nyloc 5/16-18 Flg	24:3	3220-2	1	Nut-Jam 5/16-24
10	109-3705	2	Pin-Control Pivot	25	1-808280	2	Pin-Clevis 5/16 X 1 49/64
11	3272-10	2	Pin-Cotter 1/8 X 3/4	26	1-806003	4	Hairpin-Cotter
12	32128-20	8	Nut-Whizlock 5/16-18	27	98-5975	4	Washer-Spring Disc 3/8
13	1-403180	4	Screw-HH 5/16-18 X 1 3/8 Special	30	323-6	4	Screw-HH 3/8-16 X 1
14	109-5957	2	Damper-Motion Control	31	3217-6	4	Nut-Hex 5/16-18
15	116-1393	3	Bushing,Snap	32	46-8560	4	Screw-HHF 1/4-20 X 1/2
16	116-6233	1	Wld-Brake Center Arm	33	109-6214	2	Stop-Motion Control
17	109-5010	1	Spacer	35	126-6754	1	Decal-Pioneer Logo
18	116-3155	1	Handle,Brake	36	109-6014	1	Decal-Belt Routing
19	32120-47	1	Ring-Retaining	37	99-8936	1	Decal-Control, Motion
				38	126-6753	1	Decal-Motion Control,Parkbrake

● Not serviced separately

LH Motion Control Assembly

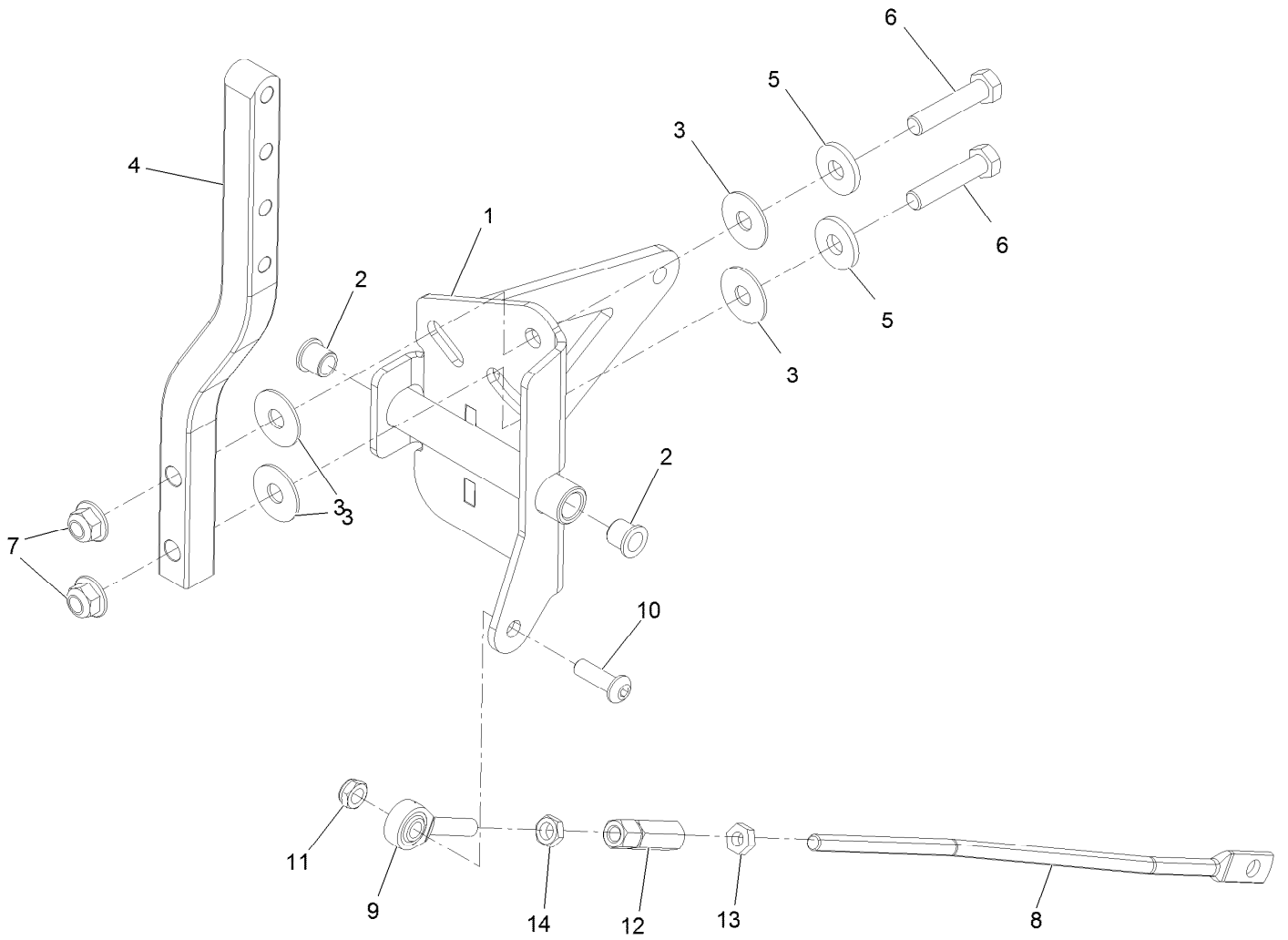

LH Motion Control Assembly (continued)

<i>Ref.</i>	<i>Part Number</i>	<i>Qty.</i>	<i>Description</i>	<i>Ref.</i>	<i>Part Number</i>	<i>Qty.</i>	<i>Description</i>
1	126-3710	1	LH Control Pivot ASM	8	116-2543	1	Link,Motion Control
2	103-9928	2	Bearing	9	2411-53	1	Bearing-Rod End, LH
3	52-2900	4	Washer-Plastic	10	3274-104	1	Screw-HSBH
4	116-3183	1	Arm-Motion Control	11	3296-47	1	Nut-Lock, NI
5	5-0838	2	Washer	12	109-3728	1	Nut-Rod Adjustment
6	323-9	2	Screw-HH	13	3220-2	1	Nut-Jam
7	104-8301	2	Nut-Flange, NI	14	3220-20	1	Nut-Jam

RH Motion Control Assembly

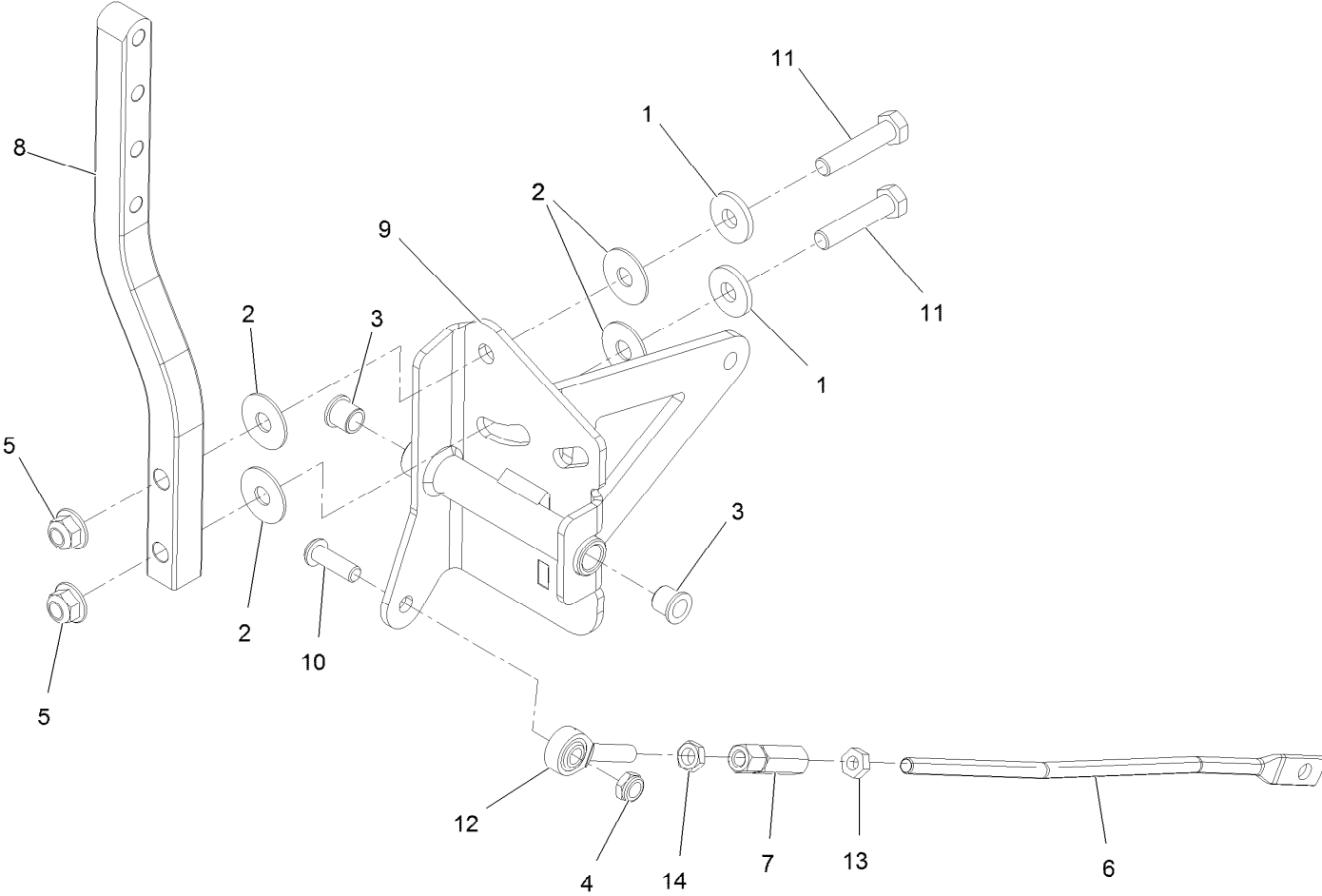

RH Motion Control Assembly (continued)

<i>Ref.</i>	<i>Part Number</i>	<i>Qty.</i>	<i>Description</i>	<i>Ref.</i>	<i>Part Number</i>	<i>Qty.</i>	<i>Description</i>
1	5-0838	2	Washer	9	126-3707	1	RH Control Pivot ASM
2	52-2900	4	Washer-Plastic	10	3274-104	1	Screw-Button Head 5/16-18 X 1
3	103-9928	2	Bearing	11	323-9	2	Screw-HH 3/8-16 X 1 3/4
4	3296-47	1	Nut-Nyloc 5/16-18 Thin	12	2411-53	1	Balljoint LH
5	104-8301	2	Nut-Nyloc 3/8-16 Flg	13	3220-2	1	Nut-Jam 5/16-24
6	116-2543	1	Link,Motion Control	14	3220-20	1	Nut-Jam 5/16-24 LH
7	109-3728	1	Nut-Rod Adjustment				
8	116-3183	1	Arm-Motion Control				

Seat Assembly

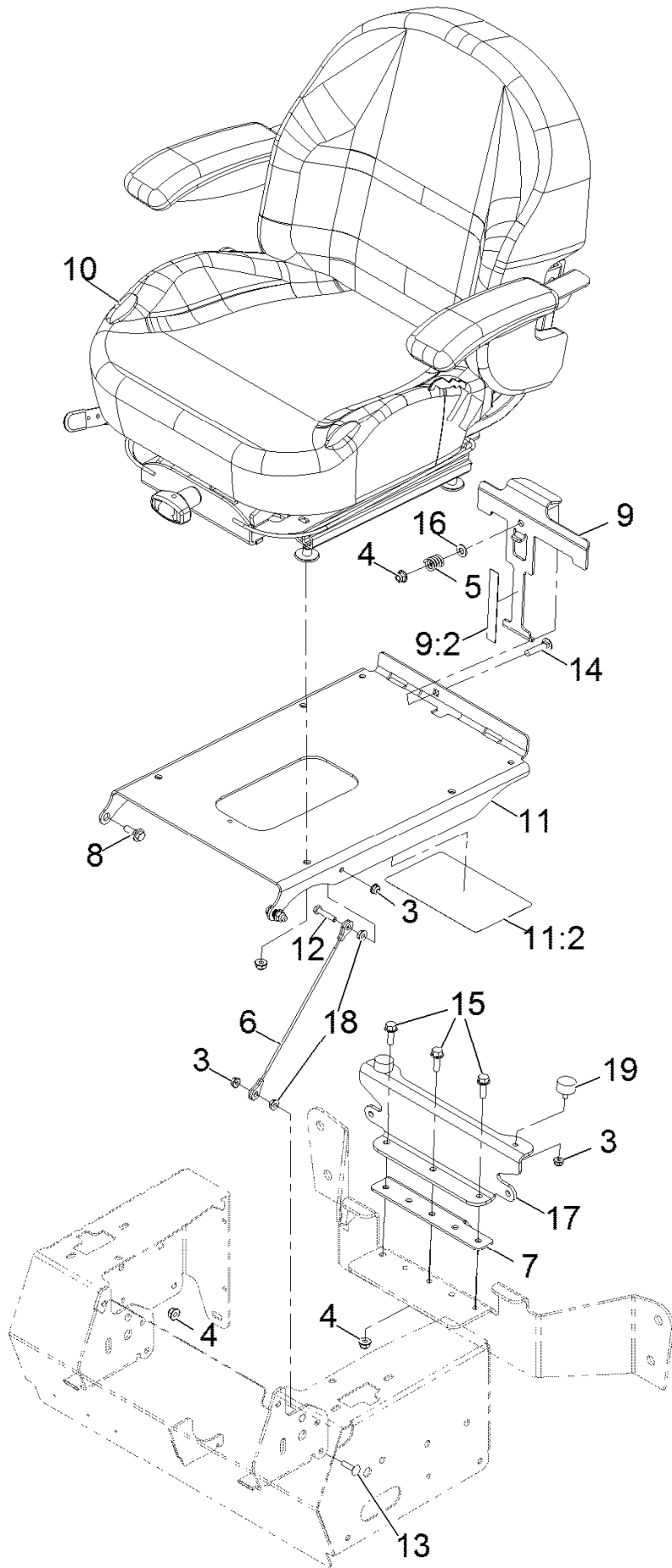

Seat Assembly (continued)

<i>Ref.</i>	<i>Part Number</i>	<i>Qty.</i>	<i>Description</i>	<i>Ref.</i>	<i>Part Number</i>	<i>Qty.</i>	<i>Description</i>
3	104-7201	4	Nut-Nyloc 1/4-20 Flg	11:2	109-6016	1	Decal-Service Aid
4	104-8300	10	Nut-Nyloc 5/16-18 Flg	12	321-8	1	Screw-HH 1/4-20 X 1 1/4
5	107-3017	1	Spring-Compression	13	3229-2	1	Bolt-Carriage 1/4-20 X 1
6	109-2628	1	Cable-Stop, Seat	14	3230-4	1	Bolt-Carriage 5/16-18 X 1 1/2
7	116-0871	1	Catch,Seat Latch	15	3234-29	3	Screw-HH Flg 5/16-18 X 1
8	116-1297	2	Screw-Shoulder	16	3256-23	1	Washer-5/16 Sae
9	116-3121	1	ASM-Seat Latch	17	126-0480-01	1	Plate-Seat Support
9:2	116-3120	1	Strip-Poly Wear	18	32128-33	2	Nut-Whizlock 1/4-20
10	126-2802	1	Kit-Seat Suspension	19	240-14	2	Bumper-Rubber
11	116-4418	1	Plate, Seat W/Decals				

Seat W/Tracks Assembly No. 126-2802

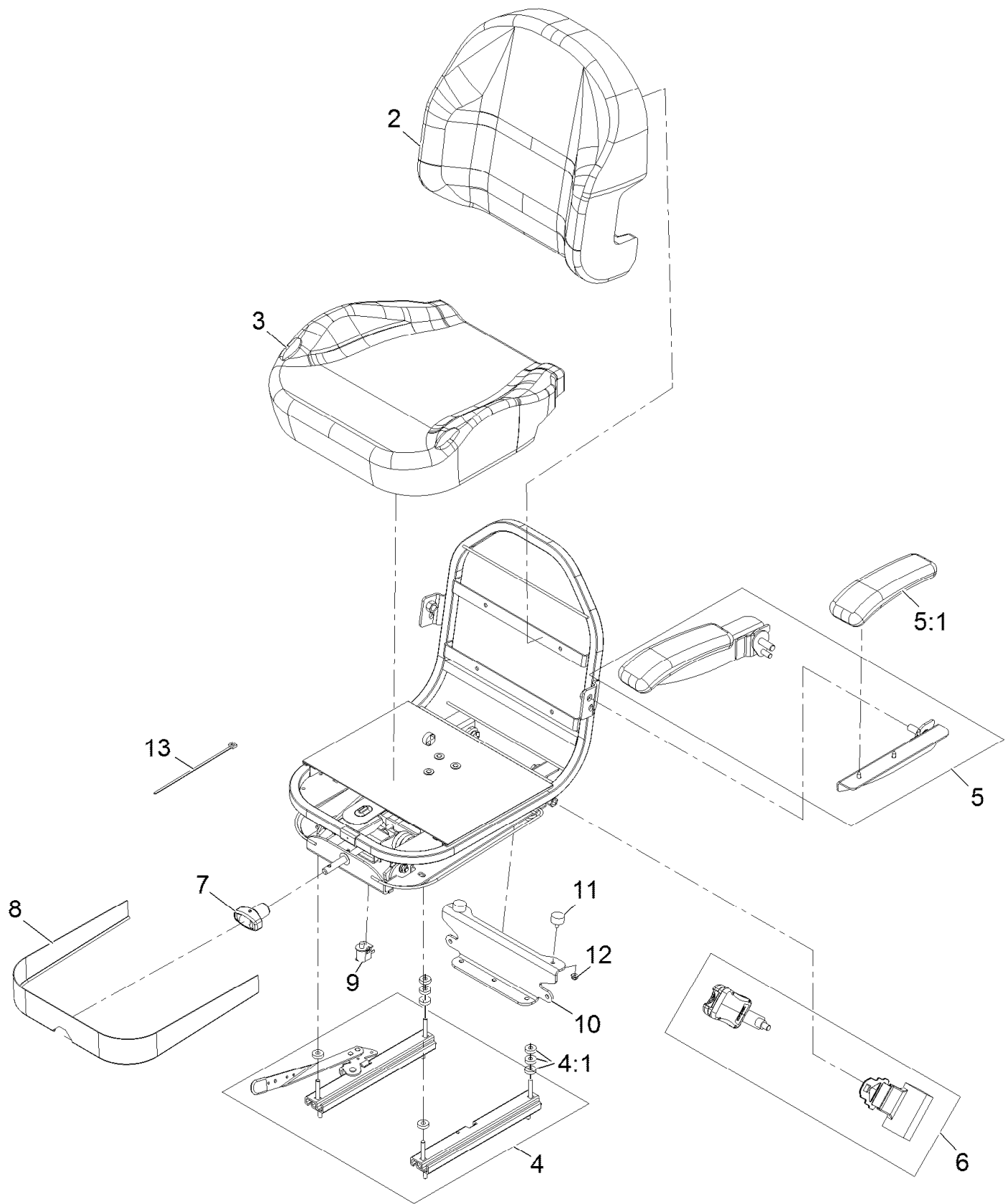

Seat W/Tracks Assembly No. 126-2802 (continued)

<i>Ref.</i>	<i>Part Number</i>	<i>Qty.</i>	<i>Description</i>	<i>Ref.</i>	<i>Part Number</i>	<i>Qty.</i>	<i>Description</i>
2	126-3505	1	Cover-Seat Back	7	130-0846	1	Knob-Adjuster
3	130-0848	1	Cover-Cushion	8	126-3506	1	Cover-Skirt W/Fasteners
4	126-3501	1	Kit-Track-Seat 4"	9	82-2190	1	Switch
4:1	26-4840	8	Spacer-Pin, Mounting	10	126-0480-01	1	Plate-Seat Support
5	126-2058	1	Armrest Kit	11	240-14	2	Bumper-Rubber
5:1	110-4163	2	Cushion-Rest, Arm	12	104-7201	2	Nut-Nyloc 1/4-20 Flg
6	126-3504	1	Kit-Seat Belt Service	13	1-303335	1	Tie-Cable 7 15/16 (Large)

Controls Assembly

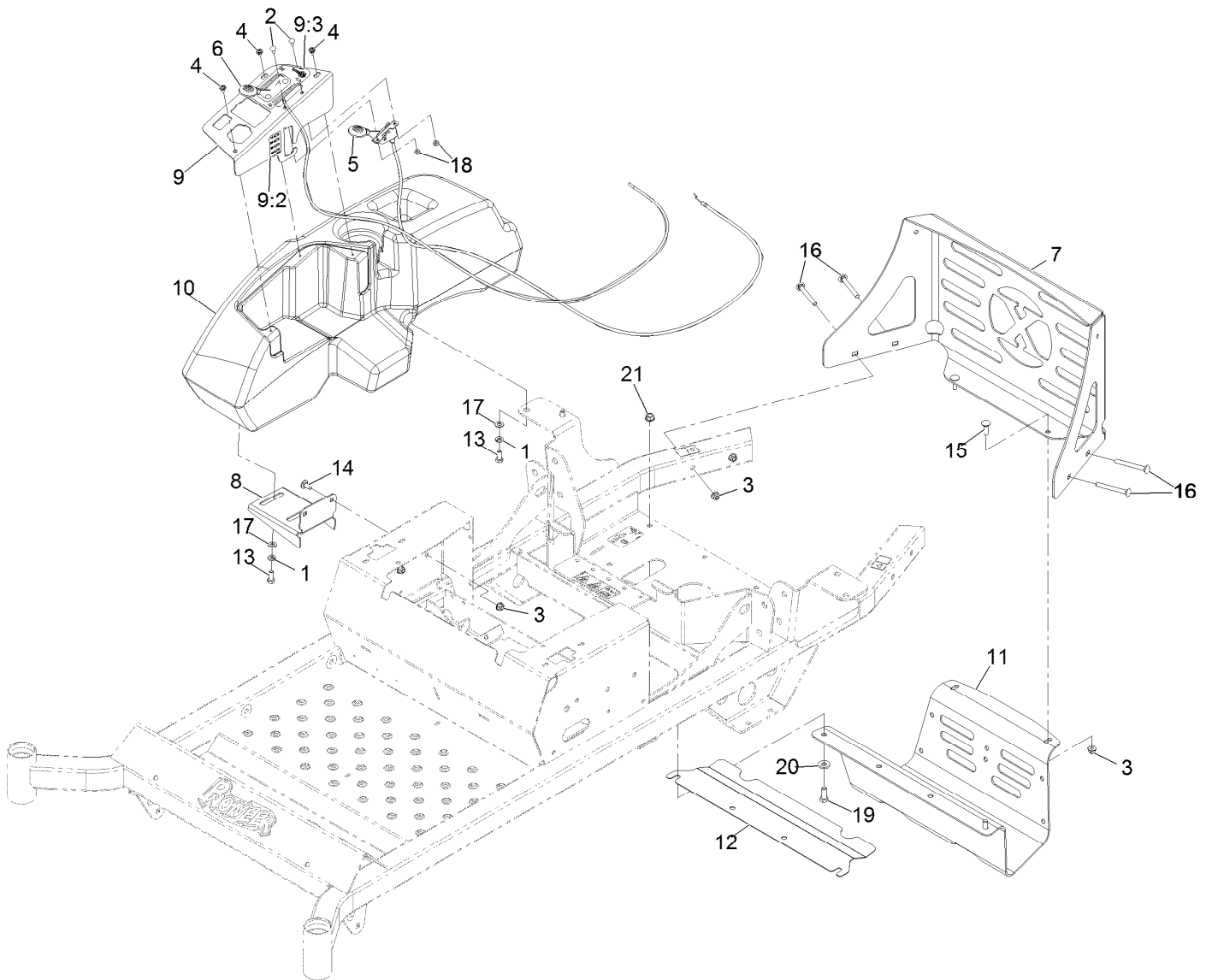

Controls Assembly (continued)

<i>Ref.</i>	<i>Part Number</i>	<i>Qty.</i>	<i>Description</i>	<i>Ref.</i>	<i>Part Number</i>	<i>Qty.</i>	<i>Description</i>
1	1-805005	4	Washer-Lock 5/16 Heavy	11	126-4275-03	1	Guard, Muffler
2	1-807513	4	Bolt-Carriage #10-24 X 1/2	12	126-0456-03	1	Shield, Heat
3	104-8300	8	Nut-Nyloc 5/16-18 Flg	13	322-3	4	Screw-HH 5/16-18 X 3/4
4	109-2661	3	Screw-PPH #10-24 X 1/2	14	3230-18	2	Bolt-Carriage 5/16-18 X 5/8
5	116-4919	1	Control,Throttle	15	3230-2	2	Bolt-Carriage 5/16-18 X 1
6	109-8747	1	Control,Choke	16	3230-9	4	Bolt-Carriage 5/16-18 X 2 3/4
7	116-3453-03	1	Panel,Rear Guard	17	3256-23	4	Washer-5/16 Sae
8	116-3495-03	1	Bracket-Tank And Fender	18	3296-2	4	Nut-Nyloc #10-24
9	116-3496	1	ASM,Control Panel W/Decal	19	323-6	2	Screw-HH 3/8-16 X 1
9:2	116-1496	1	Decal,Fuse Block	20	98-5975	2	Washer-Spring Disc 3/8
9:3	116-4465	1	Decal-Throttle Choke	21	3290-357	2	Nut-Whizlock 3/8-16
10	116-4138	1	Console,RH				

Fuel Tank Mounting Assembly

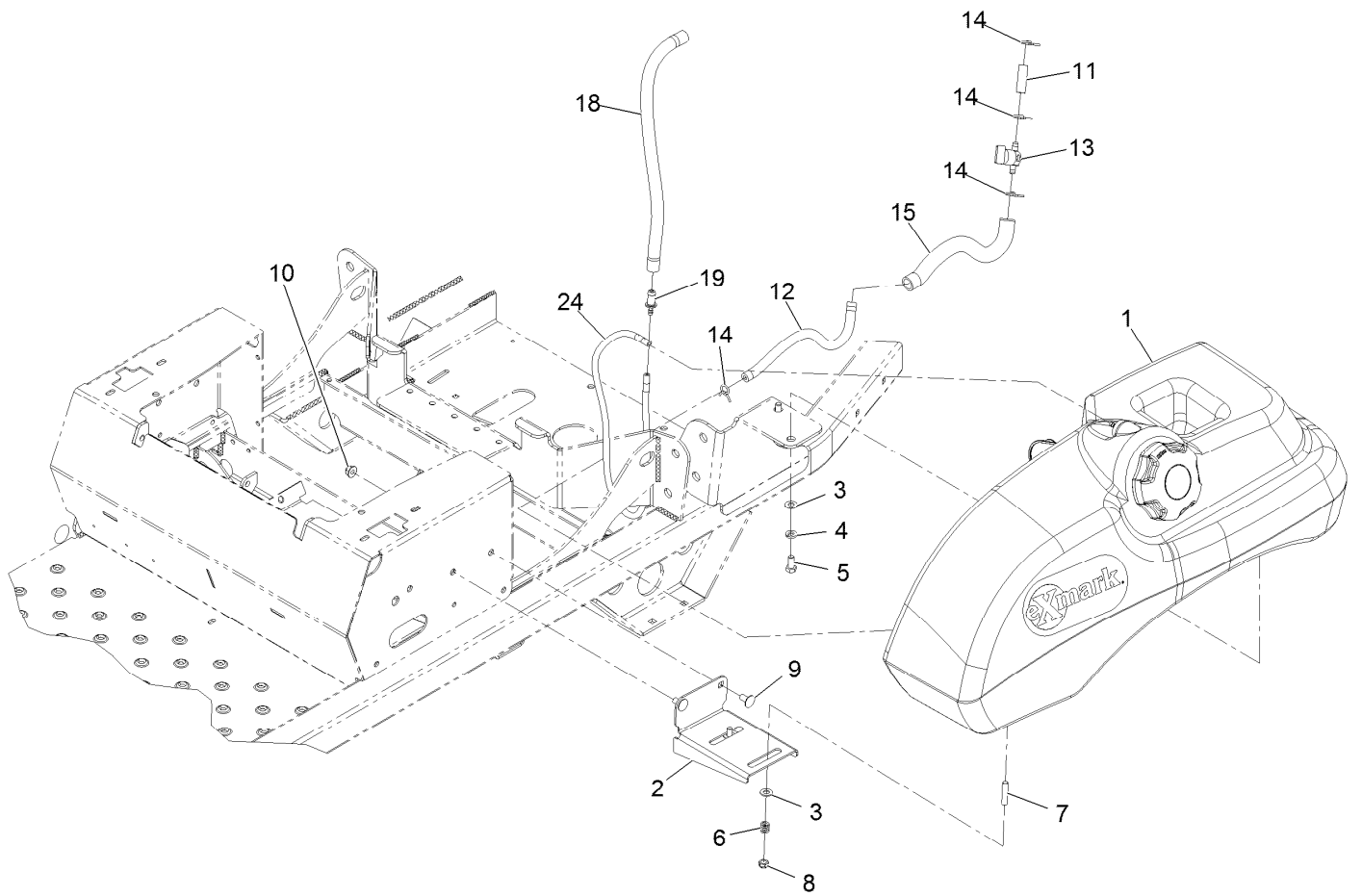

Fuel Tank Mounting Assembly (continued)

<i>Ref.</i>	<i>Part Number</i>	<i>Qty.</i>	<i>Description</i>	<i>Ref.</i>	<i>Part Number</i>	<i>Qty.</i>	<i>Description</i>
1	116-4610	1	ASM-Fuel Tank	10	104-8300	2	Nut-Nyloc 5/16-18 Flg
2	116-3495-03	1	Bracket-Tank And Fender	11	106-9492	1	Hose-Fuel
3	3256-23	4	Washer-5/16 Sae	12	109-0282	1	Hose-Fuel
4	1-805005	2	Washer-Lock 5/16 Heavy	13	1-603770	1	Valve-Fuel
5	322-3	2	Screw-HH 5/16-18 X 3/4	14	1-303077	4	Clamp-Fuel Line
6	1-633349	2	Spring-Compression	15	116-4515	1	Conduit-Fuel Line
7	1-633023	2	Stud-Fuel Tank ●	18	116-4344	1	Hose-Fuel
8	3296-47	2	Nut-Nyloc 5/16-18 Thin	19	116-4630	1	Fitting-Straight Orifice
9	3230-18	2	Bolt-Carriage 5/16-18 X 5/8	24	116-4802	1	Hose,Emissions

● Use Pro-Lock, Nut Type (P/N 1-840022, .5ml tube) on threads.

Fuel Tank Assembly No. 116-4610

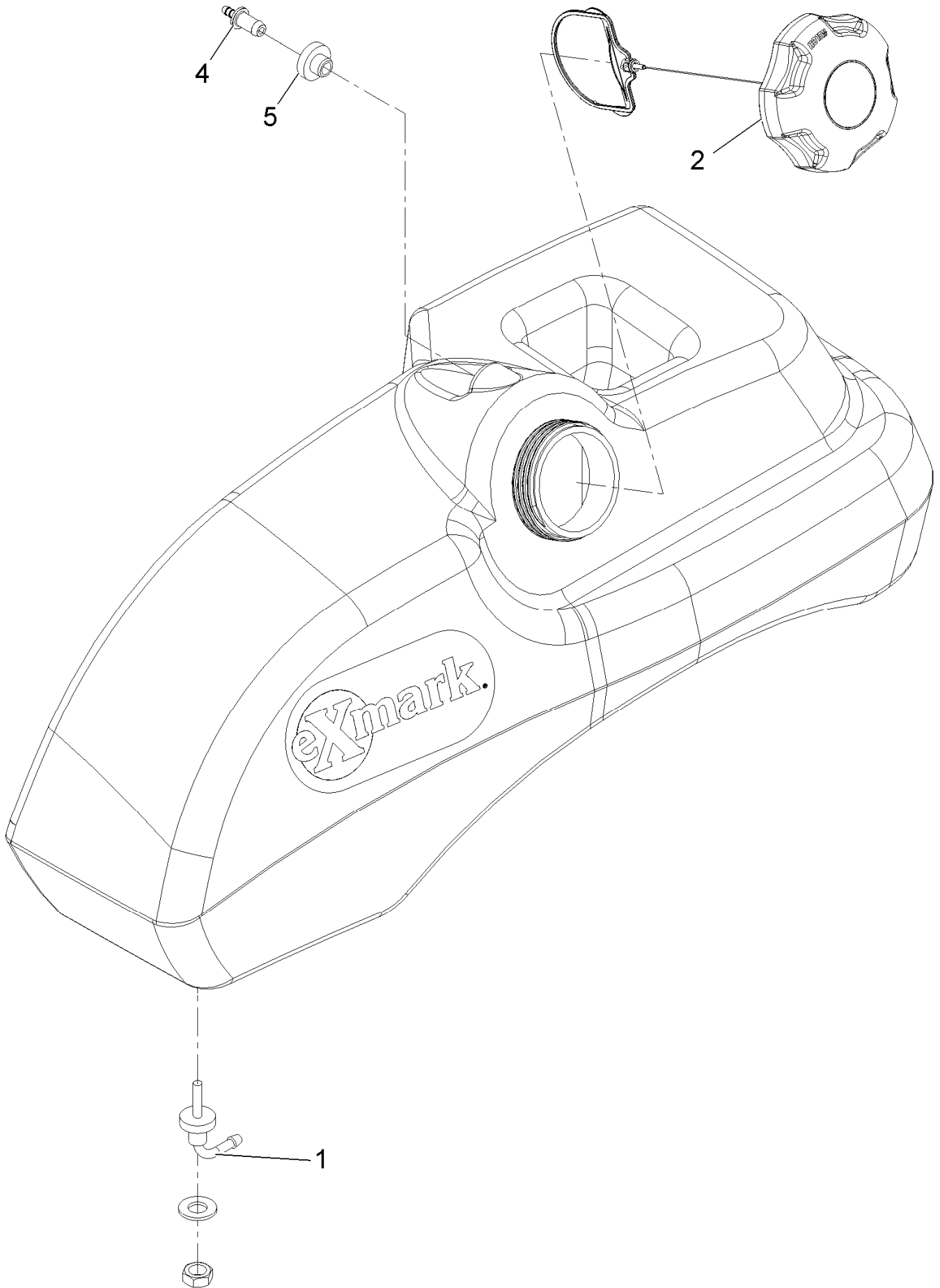

Fuel Tank Assembly No. 116-4610 (continued)

<i>Ref.</i>	<i>Part Number</i>	<i>Qty.</i>	<i>Description</i>	<i>Ref.</i>	<i>Part Number</i>	<i>Qty.</i>	<i>Description</i>
1	103-2605	1	Fitting-Fuel Bulkhead W/Strainer ●	4	116-4630	1	Fitting-Straight Orifice
2	120-5461	1	Cap-Fuel, Ratcheting	5	46-6560	1	Bushing

● Use Pro-Lock, Nut Type (P/N 1-840022, .5ml tube) on threads.

Engine Assembly

Kawasaki Replacement Parts List
(Refer To Engine Owner's Manual)

Description	Kawasaki Part
Engine Oil Filter	49065-7007
Engine Air Filter	11013-7044
Fuel Filter	49019-0014

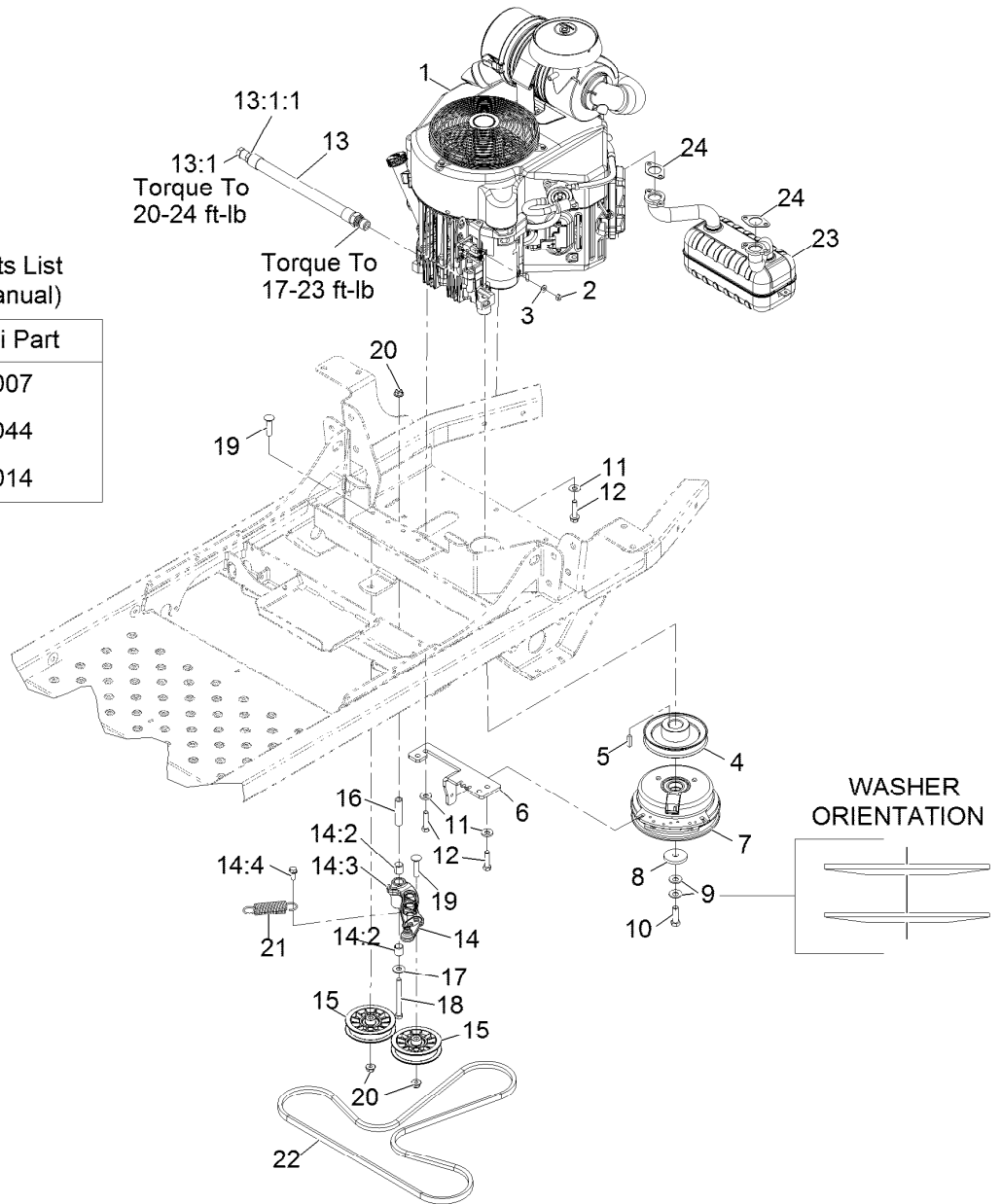

Engine Assembly (continued)

<i>Ref.</i>	<i>Part Number</i>	<i>Qty.</i>	<i>Description</i>	<i>Ref.</i>	<i>Part Number</i>	<i>Qty.</i>	<i>Description</i>
1		1	Engine-Kawasaki, Fx730V-S16-R ●■	13:1:1	237-42	1	O-Ring
2	3217-5	1	Nut-Hex	14	126-0973	1	ASM-Idler Arm W/Bearings
3	3256-22	1	Washer-Flat	14:2	1-513034	2	Sleeve-Bearing
4	116-1946	1	Sheave-Pump, Drive	14:3	302-40	1	Fitting-Grease, 90 DEG
5	1-807259	1	Key	14:4	32144-11	1	Screw-HWHTF
6	116-4773-03	1	Anchor-Clutch	15	116-2456	2	Pulley-Flat, 3.50 Dia
7	116-1604	1	Clutch	16	1-603384	1	Bushing-Pivot, Idler
8	109-6919	1	Washer-Clutch	17	3256-4	1	Washer-Flat
9	1-603610	2	Washer-Spring	18	323-15	1	Screw-HH
10	109-9761	1	Screw-HH ◆	19	3231-5	2	Screw-CARR
11	98-5975	4	Washer-Belleville	20	104-8301	3	Nut-Flange, NI
12	323-8	4	Screw-HH	21	1-603402	1	Spring-Extension
13	116-4924	1	Engine Oil Drain Hose ASM ▲	22	115-9613	1	V-Belt
13:1	353-508	1	Plug-HH	23	117-7256	1	Muffler-Kawasaki
				24	1-653313	2	Gasket-Exhaust

● Not serviced separately

▲ Use a Teflon Pipe Sealant or equivalent on threads.

◆ Use Pro-Lock, Nut Type (P/N 1-840022, .5ml tube) on threads.

■ Obtain parts from www.kawpowerepc.com

Hydraulic Assembly

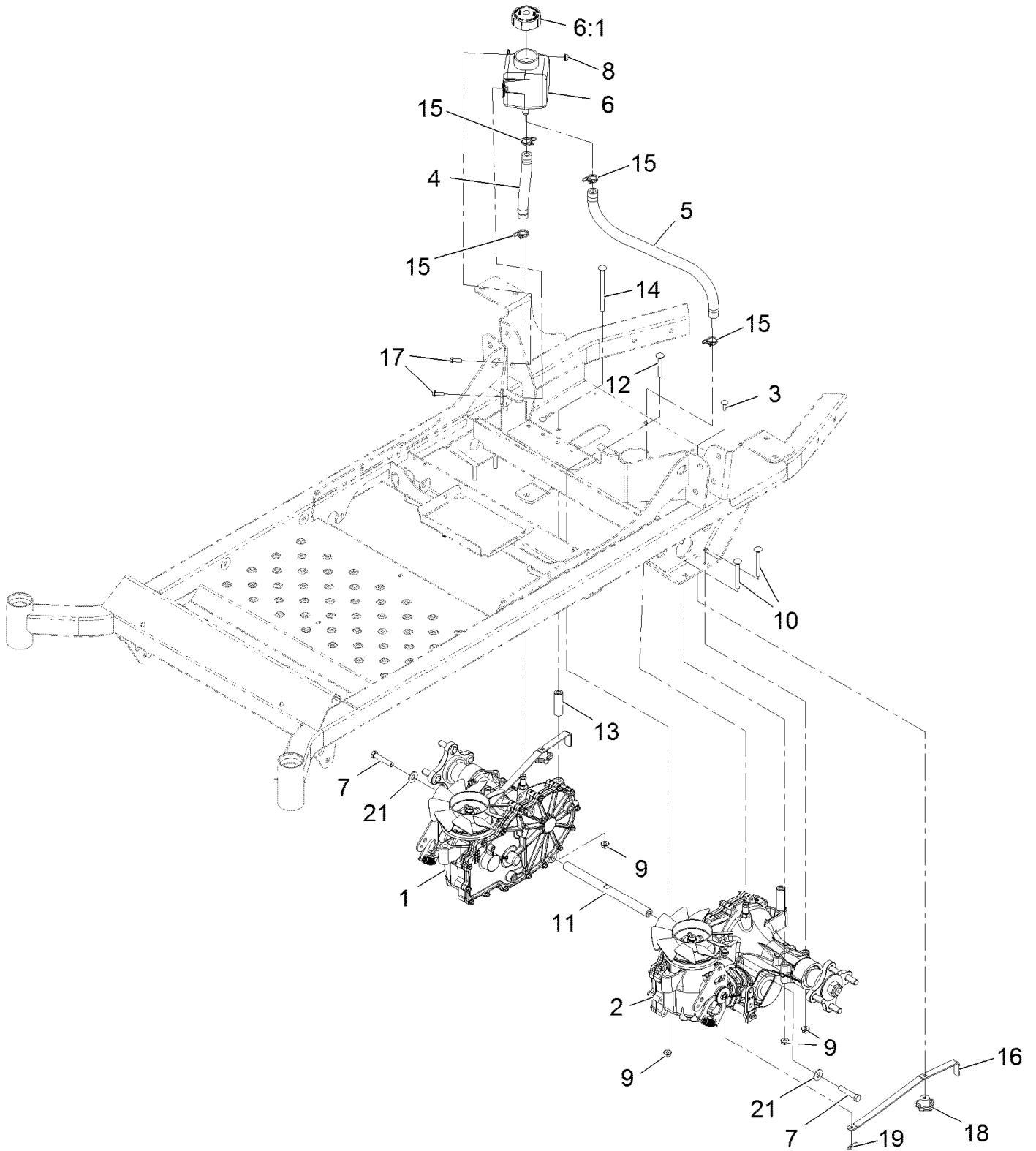

Hydraulic Assembly (continued)

<i>Ref.</i>	<i>Part Number</i>	<i>Qty.</i>	<i>Description</i>	<i>Ref.</i>	<i>Part Number</i>	<i>Qty.</i>	<i>Description</i>
1	116-6007	1	Transaxle ASM	11	116-6833	1	Shaft-Spacer
2	116-6008	1	Transaxle ASM	12	3230-7	2	Bolt-CARR
3	3229-1	2	Bolt-CARR	13	116-5809	2	Spacer-Hydro
4	116-5641	1	Hose-Hydraulic	14	3230-30	2	Screw-CARR
5	116-5642	1	Hose-Hydraulic	15	126-0327	4	Clamp-Hose
6	109-2250	1	Vent-Tank, HYD	16	109-5395	2	Arm-Hydro Bypass
6:1	109-3320	1	Cap-Reservoir, HYD	17	32105-15	2	Screw-HWH
7	94-7972	2	Screw-HH W/Loctite ●	18	108-6402	2	Knob-Handle
8	104-7201	2	Nut-Flange, NI	19	1-806003	2	Pin-Cotter
9	104-8300	8	Nut-Flange, NI	21	3256-4	2	Washer-Flat
10	3230-9	4	Screw-CARR				

● Use Pro-Lock, Nut Type (P/N 1-840022, .5ml tube) on threads.

RH Transaxle Assembly

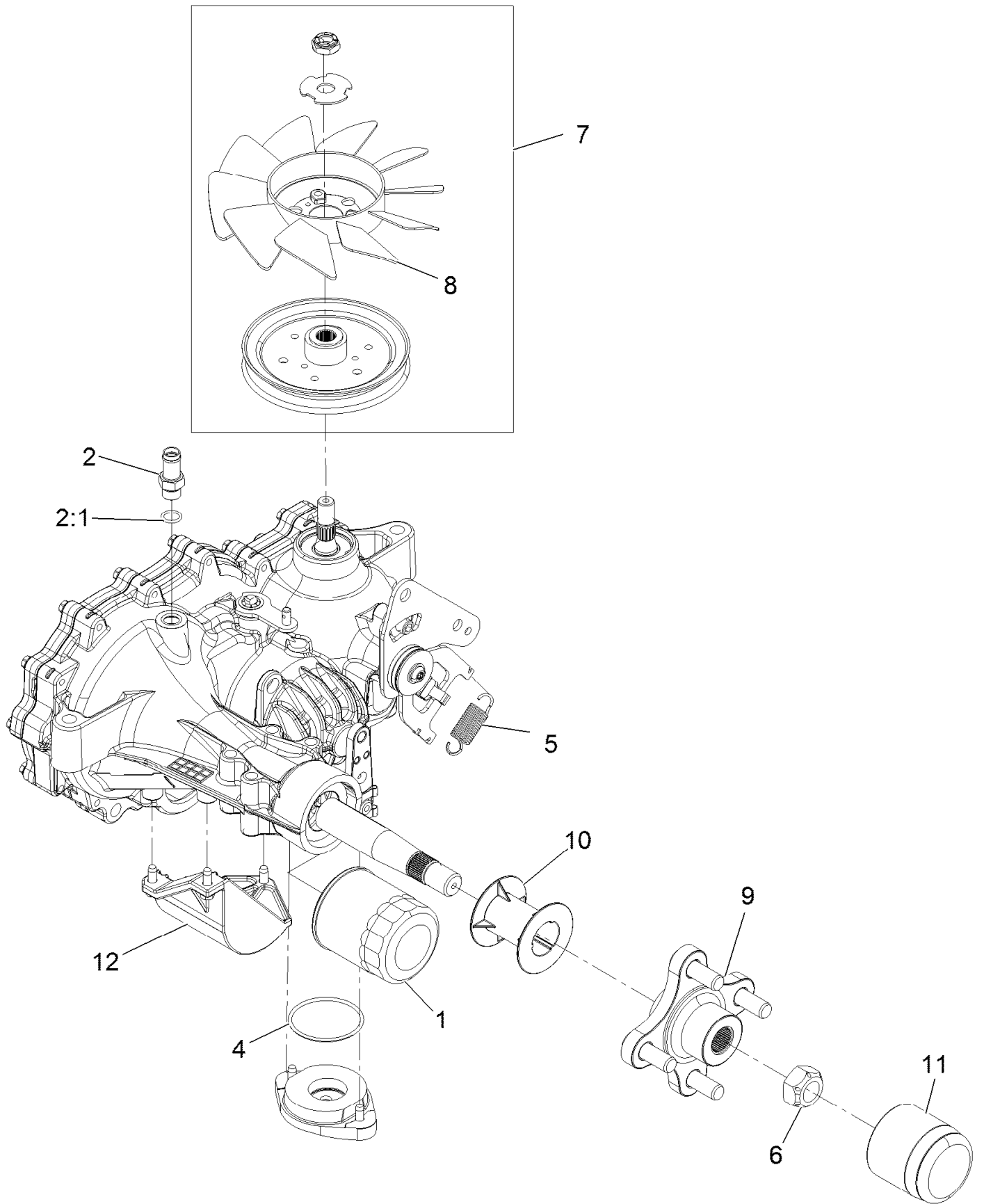

RH Transaxle Assembly (continued)

<i>Ref.</i>	<i>Part Number</i>	<i>Qty.</i>	<i>Description</i>	<i>Ref.</i>	<i>Part Number</i>	<i>Qty.</i>	<i>Description</i>
1	109-3321	1	Element-Oil Filter, HYD	8	114-8453	1	Fan-7.0
2	109-3278	1	Adapter-Straight	9	116-3872	1	Hub-Offset
2:1	237-42	1	O-Ring	10	116-6213	1	Tube-Axle 2.04
4	109-3540	1	O Ring-Seal	11	116-6214	1	Cap-Long Axle
5	109-5592	1	Spring-Extension	12	120-7981	1	Guard-Filter, RH
6	109-3536	1	Nut-Hub	99	109-3537	1	Seal Kit ●
7	121-3247	1	Fan And Pulley Kit				

● Not illustrated

LH Transaxle Assembly

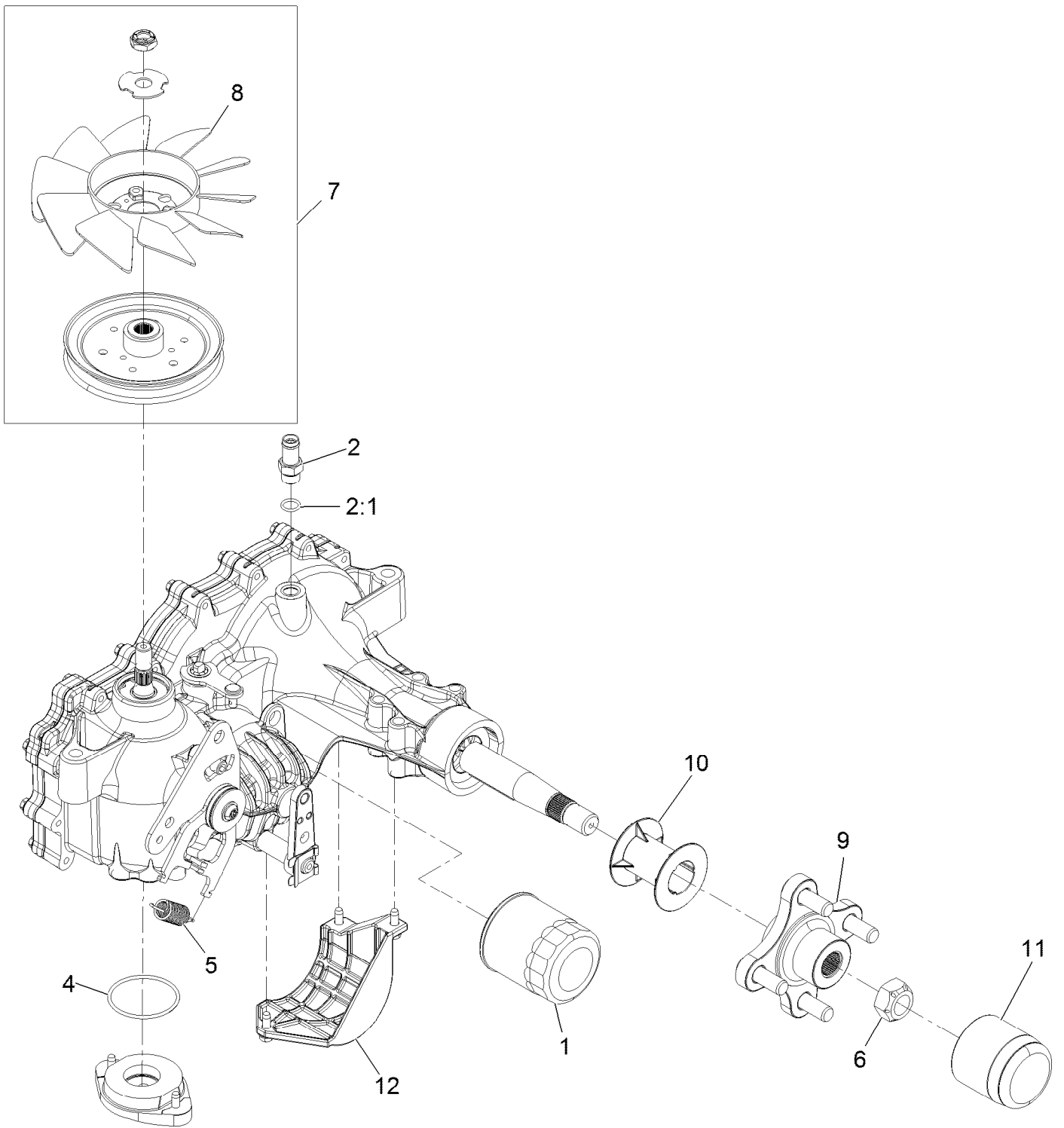

LH Transaxle Assembly (continued)

<i>Ref.</i>	<i>Part Number</i>	<i>Qty.</i>	<i>Description</i>	<i>Ref.</i>	<i>Part Number</i>	<i>Qty.</i>	<i>Description</i>
1	109-3321	1	Filter-Hydraulic	8	114-8453	1	Fan-7.0
2	109-3278	1	Adapter-Straight	9	116-3872	1	Hub-Offset
2:1	237-42	1	O-Ring	10	116-6213	1	Tube-Axle 2.04
4	109-3540	1	O-Ring-Charge Seal Cover	11	116-6214	1	Cap-Long Axle
5	109-5592	1	Spring	12	120-7979	1	Guard-Filter, LH
6	109-3536	1	Nut-Hub	99	109-3537	1	Seal Kit ●
7	121-3247	1	Fan And Pulley Kit				

● Not illustrated

Electrical Assembly

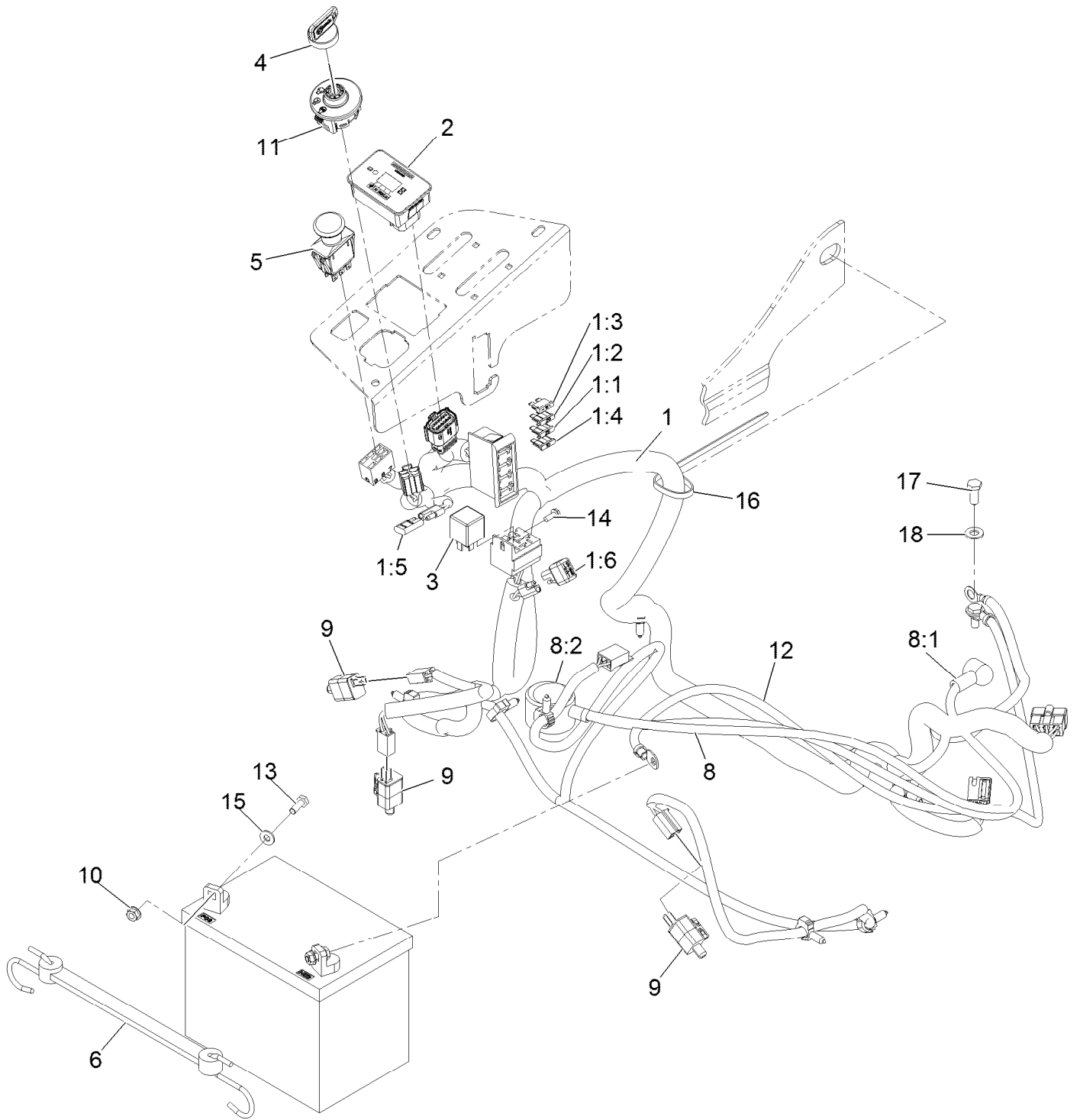

Electrical Assembly (continued)

<i>Ref.</i>	<i>Part Number</i>	<i>Qty.</i>	<i>Description</i>	<i>Ref.</i>	<i>Part Number</i>	<i>Qty.</i>	<i>Description</i>
1	116-4861	1	Harness, Wire ●	8:1	1-543393	1	Insulator-Solenoid
1:1	109102	1	Fuse-Blade, 25 Amp	8:2	109-2407	1	Insulator-Battery
1:2	1-816001	1	Fuse-Blade Type, 20 Amp	9	110-6765	3	Switch
1:3	109355	1	Fuse-Blade, 15 Amp	10	32128-33	2	Nut-Whizlock 1/4-20
1:4	218-578	1	Fuse-Blade, 10 Amp	11	117-2221	1	Switch-Ignition
1:5	116-0053	1	Cap-Plug	12	117-7240	1	Cable-Battery, Negative
1:6	103-3895	1	Diode	13	321-4	2	Screw-HH 1/4-20 X 3/4
2	116-5609	1	Module ASM	14	32144-1	1	Screw-HWH #10-24 X 1/2 Taptite
3	1-643275	1	Relay-12Vdc 40 Amp	15	3256-22	2	Washer-1/4 Sae
4	1-603511	1	Key-Ignition	16	1-303335	1	Tie-Cable 7 15/16 (Large)
4	103-2106	1	Key-Exmark Logo	17	33114-020	1	Screw-HH M8-1.25 X 20Mm
5	103-5221	1	Switch-PTO	18	33094-00	1	Washer
6	104-2466	1	Holddown-Battery				
8	109-7621	1	Positive Battery Cable ASM				

● Use dielectric grease on all unsealed connectors and terminals only. Do not apply in sealed connectors.

Notes:

Notes:

Notes:



MAXIMIZE THE PERFORMANCE OF YOUR EXMARK MACHINE.



EXMARK® PREMIUM ENGINE OIL

Exmark now offers a family of engine oil viscosities to perform well in any environment. Each viscosity has the same synthetic formulation to give you what you need in punishing conditions. We designed each grade to the highest quality, making it ideal even for diesel applications. Coupled with Exmark Premium Fuel Treatment, we have the performance products to make your machine hum.

EXMARK PREMIUM ENGINE OIL SAE 30/10W-30

- Meets zero shear requirements of a straight grade SAE 30 as well as the cold temp properties of a 10W-30.
- Most versatile oil in the industry.
- Superior corrosion protection over conventional oil - even in corrosive, humid environments.

EXMARK PREMIUM ENGINE OIL SAE 20W-50

- Perfect for your big block engine, or any application in severe service.
- Same full synthetic formulation as all other Exmark Premium viscosities.
- Also effective for use in severe service small block engines.

EXMARK PREMIUM ENGINE OIL SAE 10W-50

- Full synthetic formulation gives you peak performance. Don't settle for less.
- Wide span multi-grade combines easy starting in cold weather with maximum protection in high temperature operation.
- Reduce friction & wear over standard mineral formulations.

EXMARK PREMIUM ENGINE OIL SAE 0W-40

- The perfect choice for when the weather turns cold or unpredictable, and your Exmark UTV has to perform.
- Commercial quality for severe service.
- Advanced additive package helps prevent corrosion from long-term storage.

EXMARK PREMIUM ENGINE OIL UTV FORMULATION

- 4-cycle high-temp formulation.
- Heavier viscosity, full synthetic, perfect for your UTV.

EXMARK PREMIUM UTV EXTREME CONDITIONS GEAR OIL

- SAE 80W-90, designed to keep your UTV performing at its peak.
- Shear stable, hypoid gear lube.
- Includes a premium additive system to combat wear, oxidation, rust & corrosion.

Available from your local Exmark dealer. Find your closest dealer at exmark.com

EXMARK ACCESSORIES AND OPTIONS*

MID-MOUNT RIDING ACCESSORIES AND OPTIONS

CUSTOM RIDE SEAT SUSPENSION SYSTEM	OPERATOR CONTROLLED DISCHARGE
FULL SUSPENSION SEAT	SUN SHADE
DECK LIFT ASSIST KIT	TRASH CONTAINER
HITCH KIT	TURF STRIPER
LIGHT KIT	ULTRA VAC COLLECTION SYSTEM
12V POWER PORT	ULTRA VAC QUICK DISPOSAL SYSTEM
MICRO-MULCH SYSTEM	

OUT-FRONT RIDING ACCESSORIES AND OPTIONS

CUSTOM RIDE SEAT SUSPENSION SYSTEM	SNOW BLADE
DUAL-TAIL WHEEL	SNOWBLOWER
FLOOR PAN EXTENDER	SUN SHADE
HITCH KIT	TRASH CONTAINER
LIGHT KIT	ULTRA VAC COLLECTION SYSTEM
MICRO-MULCH SYSTEM	ULTRA VAC QUICK DISPOSAL SYSTEM
ROLL OVER PROTECTION SYSTEM (ROPS)	WEATHER CAB

WALK-BEHIND ACCESSORIES AND OPTIONS

GRASS CATCHER	TURF STRIPER
MICRO-MULCH SYSTEM	STANDON

*Some accessories and options not available for some models.

Place Model No. and Serial No.
Label Here (Included in the Literature
Pack) or Fill in Below

Model No. _____

Serial No. _____

Date Purchased _____

Engine Model No. and Spec. No. _____

Engine Serial No. (E/No) _____

© 2015 Exmark Mfg. Co., Inc.
Industrial Park Box 808
Beatrice, NE 68310
All Rights Reserved

Part No. 4502-661 Rev. A
(402) 223-6285
Fax (402) 223-5489
Printed in the USA.

